



# WATERMAINS



## Design and Construction Manual Linear Municipal Infrastructure Standards



# REVISION TRACKING

Existing Version	Version Number
October 2017	N: V1 – Original Final Submission
December 2018	V2
May 2020	V3
January 2021	V4
January 2022	V5
May 2022	V6 - Accessible
February 2023	V7
February 2024	V8

## 2024 Revisions

Section	Modification & Commentary
<b>7.3 Velocity (Pg 7)</b>	All proposed watermains can achieve a minimum flushing velocity of <del>0.8 m/s</del> 0.9 m/s
<b>11.5 Corporation Stops (Pg 11)</b>	Corporation stops are required to use No-Lead brass and be in accordance with CSA and NSF 61 & 372. Corporation stops for 25 mm, 38 mm, or 50 mm diameter water services shall have AWWA inlet thread and compression style outlet unless corporation stop is integrated with saddle.
<b>13.0 Corrosion Protection (Pg 13)</b>	Corrosion protection for watermains shall be in accordance with OPSS and shall be a <del>complete</del> two-part petrolatum coating system and/or cathodic protection in the form of zinc anodes as follows:
<b>19.3 Execution (Pipe Requirements) (Pg 19)</b>	Where specified, concrete encased pipe crossings shall be completed with unshrinkable backfill. Unshrinkable backfill shall have a compressive strength of 0.4 MPa at 28 days. Width of unshrinkable fill shall cover the full width of the trench; the length shall extend 0.5m beyond the O.D. of the crossing pipe, and extend from 0.3m below the bottom of the lower pipe, to the bottom of the upper pipe. Bond breaker shall be supplied between all pipe materials and unshrinkable fill.
<b>21.2 Material Requirements –<del>Complete Two-Part</del> Petrolatum Coating System- (Pg 21)</b>	All material for <del>complete</del> two-part petrolatum coating systems shall be in accordance with OPSS and AWWA.

<p><b>21.2 Material Requirements – Cathodic Protection – (Pg 21)</b></p>	<p>The anode must have a metallic core, or fusion bonded sleeve and have a depolarizing gypsum base material surrounding the anode. The anode must be connected using the cadweld method, in accordance with the manufacturer's specifications. <b>When fittings are epoxy-coated, the anode must be connected to the fitting's bolts so as to avoid damaging the coating.</b></p>
<p><b>23.2 Material Requirements -Corporation Stops- (Pg 23)</b></p>	<p>Corporation stops are required to use No-Lead brass and be in accordance with CSA and NSF 61 &amp; 372. Corporation stops for 25 mm, 38 mm, or 50 mm diameter water services shall have AWWA inlet thread and compression style outlet <b>unless corporation stop is integrated with saddle.</b> Only “ball type” corporation stops are approved by the City. Where an anode connection is shown, an electrical ground connection tailpiece shall be used.</p>
<p><b>24.4 Hydrant Classification (Pg 25)</b></p>	<p><b>Colour coded pressure rings must be placed on both side ports of hydrant following installation. Refer to section 15.3 for requirements.</b></p>
<p><b>26.3 Execution ( JOINTS, FITTINGS AND RESTRAINT DEVICES ) (Pg 27)</b></p>	<p>Where pipe restraint is required, mechanical restraints shall be used. Thrust blocks shall be considered for use at tees, bends (<math>\geq 45^\circ</math>), valves, caps <b>and permanent connections unless otherwise approved by a City Inspector.</b></p>
<p><b>28.1 General (Water Service Connection Procedures) (Pg 31)</b></p>	<p><b>Prior to any new connection to City's existing system, all developers or owners shall provide verification in writing of the existence of any well connections.</b></p>

<p><b>30.0 General (Testing and Commissioning) (Pg 33)</b></p>	<p>This section provides an overview of Testing and Commissioning requirements on all watermain projects in the City. Commissioning is to be carried out by a certified Third Party Agent. <b>This agent shall have the proper equipment and a minimum of five (5) years of professional experience to perform the disinfection, swabbing, pressure testing, and commissioning of watermains. Additionally, documentation confirming these qualifications shall be provided to the City upon request.</b> Forms required during the Testing and Commissioning phase are included in this manual. This section is in conformance with, and/or exceeds the MECP Watermain Disinfection Procedure Document.</p>
<p><b>33.0 Backflow Preventer (Pg 33)</b></p>	<p>The watermains will be isolated from the existing water distribution system using a physical separation until satisfactory bacteriological testing, <b>results and final connection have</b> been completed. The separation will be accomplished by using a temporary connection consisting of a RPZ backflow preventer.</p>
<p><b>30.1 Watermain Commissioning Plan (Pg 33)</b></p>	<p><b>Contractor must submit approved Watermain Commissioning Plan on the City's template. This must be reviewed and approved by the City prior to any watermain installation occurring.</b></p>
<p><b>35.5 Bacteriological Analysis (Pg 36)</b></p>	<p>Background shall not exceed <del>20</del> <b>10</b> colonies per 100 ml.</p>
<p><b>36.0 Final Connection (Pg 36)</b></p>	<p><b>Permanent connection to the City's existing watermain system shall be made within 14 calendar days of successful bacteriological testing.</b></p>

<b>36.0 Final Connection (Pg 36)</b>	<del>The Contractor shall be required to make connections to the existing watermains under positive pressure.</del>
<b>Watermain Commissioning Plan (Pg 38)</b>	Updated to 2024 Revision
<b>Standard Drawings and Details (Pg 61)</b>	<u>W-113A</u> – Additions to note section; see W-113A for more details
<b>Standard Drawings and Details (Pg 61)</b>	<u>W-315/ W-316</u> – Wrap Tracer wire to top step and/or secure to wall for easier maintenance access

# TABLE OF CONTENTS

<b>INTRODUCTION</b> .....	<b>2</b>
1.0 GENERAL REQUIREMENTS .....	2
2.0 OTHER REFERENCE DOCUMENTS.....	2
3.0 INDUSTRY STANDARDS AND SPECIFICATIONS.....	2
4.0 OTHER APPLICABLE ACTS AND LEGISLATIONS .....	3
<b>DESIGN</b> .....	<b>5</b>
6.0 DESIGN CRITERIA.....	5
6.1 <i>Design Water Demand</i> .....	5
6.2 <i>Population Equivalents Based on Land Use</i> .....	5
7.0 HYDRAULIC LEVEL OF SERVICE.....	6
7.1 <i>Pressure</i> .....	6
7.2 <i>Fire Flow</i> .....	6
7.3 <i>Velocity</i> .....	7
7.4 <i>Pipe Classification</i> .....	7
7.5 <i>Functional Servicing Report</i> .....	7
7.6 <i>Hydraulic Analysis Reporting</i> .....	7
8.0 FRICTION FACTORS .....	8
8.1 <i>New Construction</i> .....	8
8.2 <i>Existing Infrastructure</i> .....	8
9.0 SYSTEM LAYOUT .....	8
9.1 <i>General Requirements</i> .....	8
9.2 <i>New Construction</i> .....	8
9.3 <i>Existing Infrastructure</i> .....	8
9.4 <i>Horizontal and Vertical Separation</i> .....	8
10.0 PIPE REQUIREMENTS .....	8
10.1 <i>General Requirements</i> .....	8
10.2 <i>Pipe Size</i> .....	8
10.3 <i>Minimum Pipe Cover</i> .....	9
10.4 <i>Insulation of Watermain and Services</i> .....	9
10.5 <i>Pipe Material</i> .....	9
10.6 <i>Pipe Deflection</i> .....	9

# TABLE OF CONTENTS

11.0 SERVICE CONNECTION REQUIREMENTS .....	11
11.1 General Requirements .....	11
11.2 Service Size .....	11
11.3 Service Location .....	11
11.4 Service Material .....	11
11.4 Service Material Cont'd .....	11
11.5 Corporation Stops .....	11
11.6 Curb Stops .....	11
11.7 Service Boxes .....	11
11.8 Service Saddles .....	12
11.9 Tappings ( $\geq 100$ mm Services) .....	12
11.10 Service Connections to Transmission Main .....	12
11.11 Existing Service Removals .....	12
12.0 BEDDING, COVER AND BACKFILL REQUIREMENTS .....	12
12.1 Bedding, Embedment and Cover .....	12
12.2 Backfill .....	12
13.0 CORROSION PROTECTION .....	13
14.0 TRACER WIRE .....	13
15.0 HYDRANTS .....	14
15.1 General Requirements .....	14
15.2 Hydrant Spacing .....	14
15.3 Hydrant Classification .....	14
15.4 Hydrant Lead Size .....	14
16.0 VALVES AND VALVE CHAMBERS .....	14
16.1 General Requirements .....	14
16.2 Valve Size and Type .....	15
16.3 Number, Location and Spacing .....	15
16.4 Valve Boxes .....	15
16.5 Valve Extension Stem .....	15
16.6 Water Chamber (Valve/Air) Requirements .....	15
16.7 Valve Chamber Adjustments .....	16



# TABLE OF CONTENTS

17.0 WATER SAMPLING STATIONS & AUTOMATIC FLUSHING UNITS.....	16
18.0 JOINTS, FITTINGS AND RESTRAINT DEVICES .....	16
18.1 General Requirements.....	16
18.2 Fittings.....	16
18.3 Joint Restraint Requirements.....	16
<b>CONSTRUCTION SPECIAL PROVISIONS — CONTRACT .....</b>	<b>18</b>
19.0. PIPE REQUIREMENTS .....	18
19.1 General.....	18
19.2 Material Requirements.....	18
19.3 Execution .....	18
19.3 Execution (cont'd).....	19
19.3 Execution (cont'd).....	20
19.4 Measurement for Payment .....	20
20.0 TESTING AND COMMISSIONING.....	20
20.1 General.....	20
20.2 Material Requirements.....	20
20.3 Execution .....	20
20.4 Measurement for Payment .....	20
21.0 CORROSION PROTECTION.....	21
21.1 General.....	21
21.2 Material Requirements.....	21
21.3 Execution .....	21
21.4 Measurement for Payment .....	21
22.0 TRACER WIRE .....	22
22.1 General.....	22
22.2 Material Requirements.....	22
22.3 Execution .....	22
22.3 Execution (cont'd).....	23
22.4 Tracer Wire Report .....	23
22.5 Measurement for Payment .....	23

# TABLE OF CONTENTS

23.0 SERVICE CONNECTION REQUIREMENTS .....	23
23.1 General.....	23
23.2 Material Requirements.....	23
23.2 Material Requirements (cont'd) .....	24
23.3 Execution .....	24
23.3 Execution (cont'd).....	25
23.4 Measurement for Payment .....	25
24.0 HYDRANTS .....	25
24.1 General.....	25
24.2 Material Requirements.....	25
24.3 Execution .....	25
24.4 Hydrant Classification .....	25
24.5 Measurement for Payment .....	25
25.0 VALVES AND CHAMBERS .....	25
25.1 General.....	25
25.1 General (cont'd).....	26
25.2 Material Requirements.....	26
25.3 Execution .....	26
25.4 Measurement for Payment .....	26
26.0 JOINTS, FITTINGS AND RESTRAINT DEVICES .....	26
26.1 General.....	26
26.2 Material Requirements.....	26
26.3 Execution .....	27
26.4 Measurement for Payment .....	27
27.0 TEMPORARY WATERMAINS AND SERVICING .....	27
27.1 General.....	27
27.2 Material Requirements.....	27
27.2 Material Requirements (cont'd) .....	28
27.3 Execution .....	28
27.3 Execution (cont'd).....	29

# TABLE OF CONTENTS

27.4 Measurement for Payment .....	29
<b>DEVELOPMENT .....</b>	<b>31</b>
28.0 WATER SERVICE CONNECTION PROCEDURES .....	31
28.1 General.....	31
28.2 Services Connections ≤ 50 mm .....	31
28.3 Services Connections > 50 mm .....	31
28.4 Water Meters .....	31
29.0 MAINTAINING WATER QUALITY .....	31
<b>TESTING AND COMMISSIONING .....</b>	<b>33</b>
30.0 GENERAL.....	33
30.1 Watermain Commissioning Plan .....	33
31.0 INSPECTION.....	33
32.0 SHUTTING DOWN OR CHARGING WATERMAINS .....	33
33.0 BACKFLOW PREVENTER .....	33
34.0 PROCEDURE FOR WET TAPS ON WATERMAINS .....	33
35.0 SWABBING AND TESTING .....	34
35.1 Pressure and Leakage Test .....	34
35.2 Swabbing.....	34
35.3 Disinfection .....	35
35.4 Bacteriological Sampling.....	35
35.4 Bacteriological Sampling Cont'd.....	36
35.5 Bacteriological Analysis.....	36
36.0 FINAL CONNECTION.....	36
<b>TESTING AND COMMISSIONING FORMS .....</b>	<b>37</b>
<b>DETAILED ENGINEERED CROSS-SECTIONS .....</b>	<b>48</b>
<b>STANDARD DRAWINGS AND DETAILS.....</b>	<b>60</b>

# TABLE OF CONTENTS

TABLE 1. WATER DEMAND DESIGN CRITERIA .....	5
TABLE 2. RESIDENTIAL POPULATION DENSITIES .....	5
TABLE 3. EMPLOYMENT EQUIVALENT POPULATION DENSITIES .....	5
TABLE 4. DISTRIBUTION SYSTEM PRESSURE REQUIREMENTS.....	6
TABLE 5. MINIMUM FIRE FLOW TARGETS .....	6
TABLE 6. HAZEN WILLIAMS C-FACTOR.....	8
TABLE 7. MINIMUM PIPE SIZE .....	8
TABLE 8. APPROVED DESIGN RANGE, PIPE MATERIALS AND FITTING TYPES FOR WATERMAINS .....	10
TABLE 9. CORROSION PROTECTION.....	13
TABLE 10. VALVE SIZE AND TYPE .....	15

WATERMAINS

# Introduction

## INTRODUCTION

### 1.0 GENERAL REQUIREMENTS

This manual has been prepared to provide the City, consulting engineers, contractors, developers and the general public with a common reference to ensure the consistent application of watermain design and construction practices in the City.

The information provided is not intended to hinder innovation and is rooted on meeting performance requirements over the lifecycle of the infrastructure. This manual is intended to be updated as needed on a regular basis, however, proponents may submit any suggested changes via the **Design Standard Change Form (Appendix G-1 in the General Preface)** for review and approval by the City.

**The key guiding principles underlying this manual are to:**

- Prioritize the health and safety of the public by promoting water quality and providing adequate fire protection.
- Protect surface and groundwater resources.
- Undertake sustainable planning, operation and maintenance of the Water Distribution System.
- Meet regulatory and legislative requirements.
- Promote and implement shared responsibility between the City and stakeholder.

### 2.0 OTHER REFERENCE DOCUMENTS

All watermains and appurtenances shall be designed and constructed in accordance with the latest versions of this manual as well as other industry standards and best practices, including but not limited to:

- [Ontario Provincial Standard Specifications \(OPSS\) and Ontario Provincial Standard Drawings \(OPSD\)](#)
- [Ministry of Environment, Conservation and Parks \(MECP\) Design Guidelines for Drinking Water Systems](#)
- [City of Brantford Water Service Connection By-law Chapter 650](#)
- [City of Brantford Backflow Prevention By-law Chapter 649](#)
- [Drinking Water Works Permit \(DWWP\)](#)
- [Municipal Drinking Water Licensing Program \(MDWLP\)](#)

### 3.0 INDUSTRY STANDARDS AND SPECIFICATIONS

All watermain and appurtenances materials and components shall comply with the latest versions of all applicable industry standards and specifications for quality management and quality control, including but not limited to:

- The Canadian Standards Association (CSA)
- American Water Works Association (AWWA)
- American Standard and Testing Materials (ASTM)
- Underwriters Laboratory (UL)
- Factory Mutual (FM)
- Fire Underwrites Survey (FUS)
- NSF International (NSF)

### 4.0 OTHER APPLICABLE ACTS AND LEGISLATIONS

This manual does not supersede, nor replace any legislation governing the design and construction of linear water systems.

The Proponent shall be fully familiar with the latest version of these legislative requirements when carrying out design and construction of City linear projects such as:

- [Environmental Protection Act](#)
- [Accessibility for Ontarians with Disabilities Act \(AODA\)](#)
- [Municipal Act](#)
- [Ontario Water Resources Act](#)
- [Safe Drinking Water Act](#)
- [Environmental Assessment Act](#)

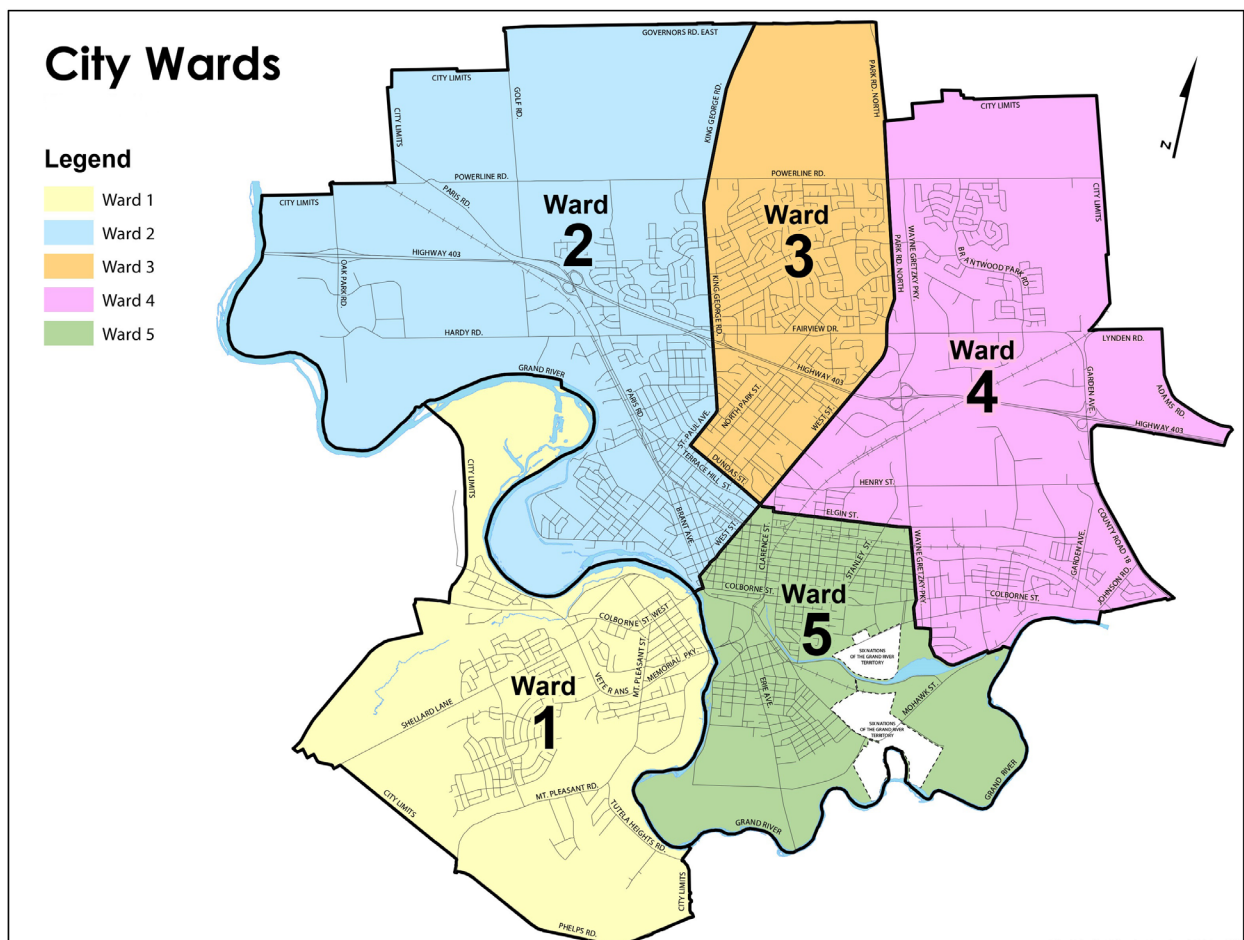

WATERMAINS  
**Design**



### DESIGN

This section outlines the minimum requirements to aid in the design of water transmission and distribution systems in the City.

#### 6.0 DESIGN CRITERIA

##### 6.1 Design Water Demand

Watermains will be sized to meet the greater of:

- Maximum day demand plus fire flow, or
- Peak hour demand.

Demands shall be calculated using design criteria outlined in **Table 1**.

Table 1. Water Demand Design Criteria

Type of Development	Average Per Capita Daily Demand (L/cap/d)	Maximum Day Factor (MDF)	Peak Hour Factor (PHF)
Residential	270	1.8	3.0
Employment	270	1.8	3.0

Note: Employment includes industrial, commercial and institutional land uses

Demand shall be determined based on Average Daily Demand (ADD) and the following appropriate factors:

Maximum Day Factor (MDF)

$$Q_{MDD} = Q_{ADD} \times \text{Max Day Factor}$$

Peak Hour Factor (PHF)

$$Q_{PHD} = Q_{ADD} \times \text{Peak Hour Factor}$$

##### 6.2 Population Equivalents Based on Land Use

The approved population densities based on type of land use shall be obtained from **Table 2** and **Table 3**, respectively.

Table 2. Residential Population Densities

Residential Housing Type	Population Per Unit (ppu)
Low Density (e.g. single and semi-detached units)	3.05
Medium Density (e.g. townhomes, row houses)	2.47
High Density (e.g. apartments)	1.60

City of Brantford, 2014 Development Charges Background Study, Hemson Consulting, March 2014

Table 3. Employment Equivalent Population Densities

Land Use Type	Equivalent Population Density (ppha)
Light Commercial (e.g. business parks, shopping malls)	90
Institutional (e.g. schools, homes for the aged)	40
Light Industrial (e.g. warehouses, autobody repair)	125

Note: ppha = Persons Per Hectare

The Proponent shall confirm population densities, based on existing and future land use, with the City prior to commencing design.

### 7.0 HYDRAULIC LEVEL OF SERVICE

#### 7.1 Pressure

Watermain sizing shall consider flow, pressure and testing requirements to maintain pressures in the distribution system under a range of operating conditions, as outlined in **Table 4**.

Pipe material and fittings shall be selected such that it can withstand all surge and transient pressures.

Table 4. Distribution System Pressure Requirements

Scenario	Pressure Requirements
Maximum Day Demand	Min. operating pressure of 275 kPa (40 psi) Max. operating pressure of 690 kPa (100 psi)
Maximum Hourly (Peak) Demand	Min. operating pressure of 275 kPa (40 psi)
Fire Flow/Emergency	Min. operating pressure of 140 kPa (20 psi) at any location in the distribution system
Testing/Commissioning	Watermain testing pressure ranges from 1035-1039 kPa (200 psi)

#### 7.2 Fire Flow

The design of new municipal water distribution systems shall meet the levels outlined in **Table 5**.

Developers are required to submit applications and designs in accordance with the City’s Site Plan Approval process and the Ontario Building Code (OBC).

Developers are encouraged to review their development specific fire flow requirements in accordance with FUS guidelines and the OBC. Site specific modifications may be required to ensure fire flow is achieved. Internal site watermains must meet fire flow targets as outlined in **Table 5** at all private hydrants they supply.

Table 5. Minimum Fire Flow Targets

Land Use	# of Hydrants	Target Fire Flow (L/s)
Dead End Residential	2	50 (4.3 MLD)
Single/Semi Family	2	75 (6.5 MLD)
Townhouse/Row House	2	125 (10.8 MLD)
Multi Family	2	150 (13.0 MLD)
Commercial	2-3	175 (15.1 MLD)
Institutional	2-3	175 (15.1 MLD)
Industrial	3-4	250 (21.6 MLD)
City Center	3	225 (19.4 MLD)



### 7.3 Velocity

Watermains shall be sized such that:

- Maximum velocity does not exceed 1.5 m/s during peak hour conditions.
- All proposed watermains can achieve a minimum flushing velocity of 0.9 m/s

Pipe velocities within transmission mains and distribution mains greater than 2.0 m/s shall be flagged for further analysis / review.

### 7.4 Pipe Classification

The classification of watermains within a distribution system depends primarily on the size of population and type of land use being serviced. Watermains are classified as follows:

#### — Transmission Mains —

Larger diameter pipes greater than or equal to 400 mm in diameter shall be dedicated to the conveyance of water supply from the treatment plant and pumping facilities to the local watermains.

#### — Distribution (Local) Mains —

Smaller diameter pipes less than 400 mm in diameter.

### 7.5 Functional Servicing Report

When required, developments must supply the City with a Functional Servicing Report (FSR) identifying water demands. This Report shall include, but is not limited to:

- Network Plans
- Building Types
- Domestic Water Demand
- Fire Demand

Fire demands are to be calculated based on FUS guidelines and the OBC. When the FUS calculated fire demands exceed 150L/s, the developer must include building specific calculations identifying the fire systems requirements.

This FSR will be utilized to demonstrate the local and system wide impacts of the proposed design.

### 7.6 Hydraulic Analysis Reporting

Hydraulic Analysis Reports must be completed for all new and existing infrastructure. This Report shall include, but is not limited to:

- Confirm sufficient capacity
- Identify water flow direction
- Confirm no detrimental impacts
- Confirm size and configuration appropriate for required LOS
- Complete a transient pressure analysis on transmission watermains.

This report will be completed by the City's Modelling Consultant and utilizing the calibrated City's Hydraulic Model. The Developer will be provided a quotation for the costs. Payment must be received prior to the modelling being completed.

## 8.0 FRICTION FACTORS

### 8.1 New Construction

The C-Factors that shall be used in the Hazen-Williams equation for the design of new water mains, regardless of pipe material, are provided in **Table 6**. Shall be in accordance with the latest versions of MECP guidelines.

The Hazen Williams formula is as follows:

$$Q_{\text{DESIGN}} = 0.849 \times C \times A \times R^{0.63} \times S^{0.54}$$

where,

Q=Design Flow (m<sup>3</sup>/s)

C=Hazen Williams friction coefficient (see **Table 5**)

R=Hydraulic Radius (m)

S=Slope of Energy Grade Line (m/m)

A=Cross-Sectional Flow Area (m<sup>2</sup>)

Table 6. Hazen Williams C-Factor

Pipe Diameter - Nominal (mm)	C - Factor
150	100
200 - 250	110
300 - 600	120
Over 600	130

### 8.2 Existing Infrastructure

In evaluating the existing water system, C-Factors shall be determined by actual field tests. In calculating maximum velocities for transient pressure, a C-Factor of 120 will be used for new pipe conditions.

## 9.0 SYSTEM LAYOUT

### 9.1 General Requirements

A distribution network shall be designed to ensure flexibility of operation and to minimize the area of the community affected by shutdowns during watermain network repairs. Water mains may be looped to reduce dead ends, prevent stagnation of water and minimize service disruption during repairs, but must be supported by a hydraulic modelling report.

### 9.2 New Construction

All new water mains shall be located in accordance with the City's Standard Drawings and Detailed Cross-Sections.

### 9.3 Existing Infrastructure

Location of replacement water mains shall be determined specifically based on the location of existing utilities and other conditions. All attempts shall be made to keep the existing watermain in service until the new watermain is commissioned.

### 9.4 Horizontal and Vertical Separation

Clearances between water mains, sanitary and storm sewers shall be based on the MECP Procedure F-6-1: Procedures to Govern the Separation of Sewers and Water mains.

## 10.0 PIPE REQUIREMENTS

### 10.1 General Requirements

The pipe and appurtenances identified in this manual refer to conventional open cut installation methods. Where special methods for installation are proposed to be used, (e.g. tunneling, micro-tunneling, jack and bore) drawings and specifications must be submitted with the overall design.

### 10.2 Pipe Size

Standard pipe sizes (mm) for water mains are as follows: 150, 200, 250, 300, 400, 500, 600, 750, 1050 and 1200. Larger diameters are permitted as required.

Table 7. Minimum Pipe Size

Land Use Type	Minimum Pipe Size (mm)
Residential	150
Industrial, Commercial and Institutional	300

### 10.3 Minimum Pipe Cover

The depth of cover for watermains and appurtenances shall be greater than the frost penetration and shall not be less than 1.85 meters minimum.

The depth of cover for water services shall maintain a cover of 1.85 meters minimum.

### 10.4 Insulation of Watermain and Services

Where the minimum specified cover over services or watermain cannot be achieved, sufficient insulation to prevent freezing of such sections of services or watermain shall be provided.

Additionally, where minimum horizontal separation of services or watermain from ventilated underground structures (catchbasins, maintenance holes, etc.) cannot be achieved, sufficient insulation to prevent freezing of such sections of services or watermain shall be provided.

Unless otherwise specified, watermain and services with less than 1.5m depth of cover or horizontal separation from ventilated underground structures at any location along the length shall be insulated.

All joints to be taped and staggered.

The width and thickness of insulation used shall be as specified in Standard Detail Drawings **W-312, W-312A & W-312B**.

### 10.5 Pipe Material

All materials in contact with drinking water shall meet all applicable quality standards set by the following:

- American Water Works Association (AWWA).
- Canadian Standards Association (CSA)
- NSF/ANSI Standard: Drinking Water - Health Effects.

**Table 8** identifies pipe materials that are permitted. Watermain pipe must be delivered to the site factory sealed by the pipe manufacturer. Any pipe not factory sealed by the manufacturer shall be rejected.

In determining the suitable pipe class to be used, thrust force, internal pressure, surge pressure, live load, dead load, soil type and trench conditions shall be considered in the calculation.

The pipe manufacturer's recommendations shall be incorporated into the design.

### 10.6 Pipe Deflection

Wherever it is necessary to deflect the pipe from a straight line either in the vertical or horizontal direction, the amount of deflection shall not exceed one (1) degree per joint.

Restrained or mechanical joint bends are preferred. Pipe bending will not be allowed.

Table 8. Approved Design Range, Pipe Materials and Fitting Types for Watermains

Main Size (mm)	Joint Type	Specification	General Comments
<b>Polyvinyl Chloride (PVC)</b>			
≤ 500 * >500 must be approved by the City.	Gasketed Bell and Spigot	Pipe: AWWA M23, AWWA C900, CSA 137.3, FM 1612 approved, UL 1285 listed, NSF 61 & 372 certified  Fittings: (100 to 300mm) AWWA C907, CSA B137.2  (250 to 300mm) AWWA C900, CSA B137.3, FM 1612 approved, UL 1285 listed, NSF 61 & 372 certified	Proponent shall determine pressure class and rating based on project requirements.  Use of PVC for distribution main only.  Service saddles or service tees shall be used when connecting services to PVC mains.
<b>Molecularly Oriented Polyvinyl Chloride (PVCO)</b>			
150 - 300	Gasketed Bell and Spigot	Pipe: NSF 14, 61 & 372 ASTM D1784, D3139, F477 & F1483, AWWA C909, CSA B137.3.1.09., FM 1612  Fittings: Match PVC	Proponent shall determine pressure class and rating based on project requirements.  Use of PVCO for distribution main only.  Colour-coded blue.  Service saddles or service tees shall be used when connecting services to PVC mains.
<b>Concrete Pressure Pipe (CPP)</b>			
400 and 500	Gasketed Bell and Spigot, High Sulfate Cement for all diaphraging and repairs as specified by the manufacturer	AWWA C303	Pre-tensioned Concrete Cylinder Pipe.
500 ≤ 1350		AWWA C301(L) and C304	Pre-stressed concrete steel cylinder lined type.
> 1350		AWWA C301(E) and C304	Pre-stressed concrete embedded steel cylinder type.
<b>Ductile Iron, Hyprotec Coated</b>			
≤ 400	Mechanical, Flanged or Tyton, High Sulfate Cement for all diaphraging and repairs as specified by the manufacturer	AWWA C104, C105, C110, C111, C115, C150, C151, C153  Fittings to be Hyprotec-coated	Project Specific basis as determined by design review process.  Cathodic protection is required.
<b>High Density Polyethylene (HDPE)</b>			
≤ 400	Butt Fusion	AWWA C906	Project specific basis as accepted by the City and determined by design review process.

## 11.0 SERVICE CONNECTION REQUIREMENTS

### 11.1 General Requirements

The following section outlines the pipe and appurtenances required for service connections.

### 11.2 Service Size

Service connections shall be nominal diameter of 25 mm, 38 mm, 50 mm or 100 mm pipe. All new service connections shall be a minimum 25 mm to property line.

75 mm services are not permitted. Service connections with a nominal diameter of less than 15mm are obsolete.

### 11.3 Service Location

The preferred location for the water service connection is shown in Standard Drawings of this manual.

No water service shall have less than 1.85 m of cover measured to finished grade directly above the service.

No relocated water service shall be allowed to pass within 1.2 m of any catch basin, storm sewer manhole or sanitary manhole.

### 11.4 Service Material

Service connection pipe shall be approved Type 'K' soft copper, nominal diameter of 19mm (only for cut, extend and reconnect), 25 mm, 38 mm, 50 mm. Kinked, crushed or distorted tubing shall not be used. Only compression type fittings are to be used between the watermain and the water meter.

Approved crosslinked 25 mm polyethylene (PEX) pipe is permitted in new residential developments from watermain to water meter only in accordance with CSA, NSF 61 & 372 and ASTM, complete with a tracer wire.

### 11.4 Service Material Cont'd

PVC pipe is preferred for 100 mm diameter and larger water services.

### 11.5 Corporation Stops

Corporation stops are required to use No-Lead brass and be in accordance with CSA and NSF 61 & 372. Corporation stops for 25 mm, 38 mm, or 50 mm diameter water services shall have AWWA inlet thread and compression style outlet unless corporation stop is integrated with saddle.

Only "ball type" corporation stops are approved by the City.

### 11.6 Curb Stops

Curb stops shall be installed at the property line unless otherwise specified.

Curb stops are required to use No-Lead brass and be in accordance with CSA, NSF 61 & 372. Only "ball type" curb stops are approved by the City and shall come complete with an electrical grounding clamp for attachment of the anode.

### 11.7 Service Boxes

The service boxes shall be for 1.7 m to 2.0 m bury (regardless of size), but shall be extended if special depths are encountered. The service box shall be located at property line unless otherwise specified.

Slide service boxes require type 304 stainless steel rods and stainless steel cotter pins.

### 11.8 Service Saddles

Service saddles shall be used on all services installed off of PVC, PVC-O and asbestos cement watermain and on all services larger than 25 mm installed off of ductile iron watermain. All service saddles will require a double bolt closure. PVC service tees will be considered on a case by case basis.

### 11.9 Tappings ( $\geq 100$ mm Services)

The connection of any proposed watermain or water service with a diameter one standard size down from the existing watermain shall be made using a cut-in tee and valve. Services two standard sizes down can be made using a tapping sleeve.

### 11.10 Service Connections to Transmission Main

Private service connections are prohibited on transmission mains. Existing connections will remain until replacement or rehabilitation of the main.



### 11.11 Existing Service Removals

Obsolete water services, valves and curb stops must be removed from the main to preserve water quality, prevent leaks and avoid confusion. In the case of a tee, it is to be removed and a filler piece is to be installed.

## 12.0 BEDDING, COVER AND BACKFILL REQUIREMENTS

### 12.1 Bedding, Embedment and Cover

Bedding and cover material shall consist of ONLY Granular A. Bedding, cover and embedment materials shall meet OPSS & OPSD.

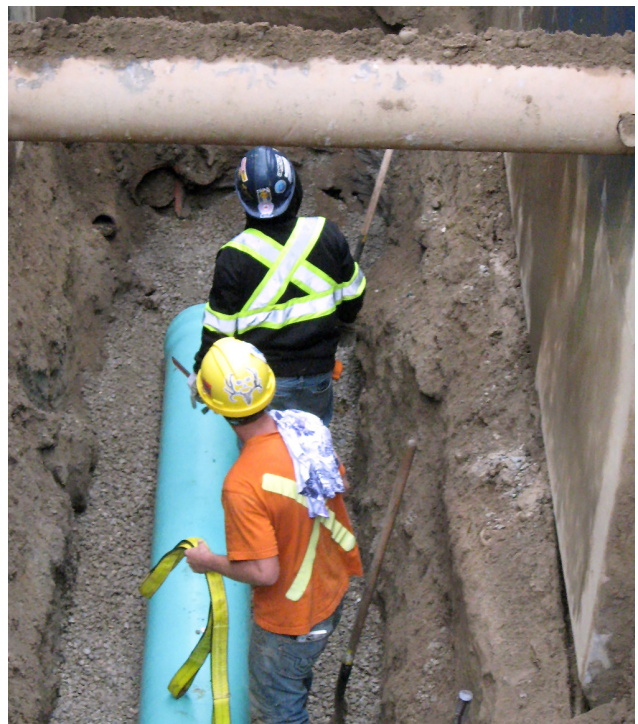

Bedding, embedment and cover materials shall be placed for the full width of the trench and mechanically compacted to 98% of Standard Proctor Maximum Dry Density (SPMDD), as determined by ASTM D698.

### 12.2 Backfill

Backfill shall be considered as starting at 300 mm above the watermain.



### 13.0 CORROSION PROTECTION

Corrosion protection for watermains shall be in accordance with OPSS and shall be a two-part petrolatum coating system and/or cathodic protection in the form of zinc anodes as follows:

Table 9. Corrosion Protection

Component	Petrolatum System	Cathodic Protection
Buried Metallic Fittings – on flanged surfaces, nuts, bolts, tie rods, clamps, valves, sleeves and couplings	Required	Required
Mechanical Restraints	Required	Not Required
Valve Chambers – surface of pipes, valves and appurtenances	Required	Not Required
Metallic Watermain – at each metallic component, curb stops, service saddles and on lateral piping of hydrants	Not Required	Required
PVC Watermain – 1.0 m horizontally from each metallic component	Not Required	Required

### 14.0 TRACER WIRE

Tracer wire shall be installed on all non-conductive watermains, fittings, hydrant laterals and water services except where such water service pipe is of copper material.

The wire shall be installed in such a manner as to be able to properly trace all watermains, hydrant laterals and water services without loss or deterioration of signal or without the transmitted signal migrating off the tracer wire. Test Boxes shall be clearly marked. The maximum distance between test boxes shall be 300m.

Tracer wire shall be specifically manufactured for direct burial applications.



## 15.0 HYDRANTS

### 15.1 General Requirements

Hydrants shall be placed on the same side of the street as the watermain and shall be perpendicular to the street and the watermain.

All hydrants and hydrant risers shall conform to the latest revision of CSA and AWWA. Wet barrel hydrants shall not be permitted.



Hydrants within the right of way shall be painted yellow and private hydrants shall be painted red. All hydrants shall be complete with Storz connections. Hydrants shall be located on lot lines and 2.0 m horizontal clearance from edge of driveway.

The inside of hydrant boots shall be epoxy coated. Hydrants to be installed within 75 mm from finished grade to the breakaway flange.

### 15.2 Hydrant Spacing

The maximum allowable spacing between fire hydrants shall be 120-150 m within a City right-of-way and they shall each be separated by a valve on the main line. Maximum spacing of fire hydrants within private property shall be 90 m. Spacing of all hydrants shall be determined such that all lots are within coverage of at least two hydrants. The backup hydrant shall not be supplied for the same dead end main as the primary hydrant.

### 15.3 Hydrant Classification

Municipal and private hydrants shall be colour-coded with UV and weather resistant plastic hydrant rings on each cap to indicate their class in accordance with NFPA 291:

- Blue – Class AA; rated capacity of 5680 L/min or greater (1500 usgpm)
- Green – Class A; rated capacity of 3785-5675 L/min (1000-1499 usgpm)
- Orange – Class B; rated capacity of 1900-3780 L/min (500-999 usgpm)
- Red – Class C; rated capacity of less than 1900 L/min (500 usgpm)

Two rings per hydrant (hose ports only). Rings to be reflective for night visibility; scratch & tear resistant w/ pre-printed standard language: "For Fire Department Use Only. Unauthorized Use is Theft. Violators will be Prosecuted." Text colour shall be selected to provide maximum contrast with hydrant ring.

### 15.4 Hydrant Lead Size

Hydrant leads shall be 150 mm. All hydrants shall be connected to the watermain with an anchor type tee and controlled independently by a 150 mm gate valve. The hydrant barrel shall have a minimum depth of 1.85 m. A maximum of one hydrant extension (300mm or less for new developments) between the hydrant barrel and hydrant shall be permitted for deeper installations.

## 16.0 VALVES AND VALVE CHAMBERS

### 16.1 General Requirements

All valves in contact with drinking water shall be in accordance with AWWA and be NSF 61 & 372 certified.

### 16.2 Valve Size and Type

Line valves shall be the same size as the watermain and shall conform to the type and specification outlined in **Table 10**. All valves must open in a clockwise direction.

Combination air release and vacuum valves shall be provided at all high points on local & transmission mains. They shall be located in chambers with vent lines that include a check valve assembly for flood protection. All combination air release and vacuum valves shall be provided with isolation valves and drains.

Drain valves shall be provided at each low point for transmission mains.

Table 10. Valve Size and Type

Valve Size	Type / Specification
Valves ≥ 400 mm	Butterfly (AWWA C504) or Resilient seat gate valves (AWWA C509)
Valves <400 mm	Gate valves (AWWA C500) or Resilient seat gate valves (AWWA C509)

### 16.3 Number, Location and Spacing

Valve spacings shall meet the minimum requirements as outlined by the MECP. Valves shall be located at the extension of the property line and all efforts shall be made so they are not located in the centre of the intersection. Mainline valves shall be included in the vicinity of hydrant tees and specialty valves (PRV) to facilitate flushing and testing.

The placement of valves on distribution mains is to be such that any section of the system can be isolated by operating a maximum of four valves. Each isolated section in a looped system may contain up to a maximum of 45 services and no more than one hydrant taken out of service. A mainline valve shall be supplied at each hydrant tee.

### 16.4 Valve Boxes

Valve boxes shall be 130 mm slide type.

### 16.5 Valve Extension Stem

Valve extension stems shall be installed as required when the distance between the top of the operating nut and the proposed final grade exceeds 1.2 m. Extension stems shall be a 25 mm solid square bar.

### 16.6 Water Chamber (Valve/Air) Requirements

In order to facilitate operation and maintenance activities, valve chambers shall provide the following:

- Minimum headroom of 2.1 m. Minimum of 0.5 m and maximum of 0.8 m clearance between the invert of the watermain and the chamber floor.
- Minimum of 0.3 m cover above the chamber top slab.
- Minimum of 0.6 m horizontal clearance on valves and 0.3 m below valves to allow sufficient space for servicing and / or removal when required.
- Valve chamber size shall be selected to adequately accommodate all valves and other ancillary equipment. All concrete valve chambers shall be provided with adequate thrust restraint, approved waterproofing, sealed joints and insulated above the frost depth.
- PVC or PVCO is not permitted through a valve chamber. Piping at valve chambers shall transition from PVC or PVCO to ductile iron using couplings located 500 mm from chamber walls.
- CPP piping will be permitted through chambers where the piping along the mainline is CPP.
- Valve chambers located in gravel shoulders shall be provided with a paved area sufficient for parking one vehicle. See detail **A-101** in the standard drawings section of this manual.

### 16.7 Valve Chamber Adjustments

Valve Chamber frame and covers should be adjusted to final grades with cast-in-place concrete. For maintenance holes situated in roadways, the frame and covers shall be adjusted using the coring method after pavement of surface asphalt.

## 17.0 WATER SAMPLING STATIONS & AUTOMATIC FLUSHING UNITS

Water Sampling Stations and Automatic Flushing Units are required to maintain and record Water Quality within the water distribution system.

Water Sampling Station locations will be identified and required at select locations within the City. The equipment installed will be as per the Approved Products List. The connection to the water distribution system will be made with a 25mm copper water service and curbstop.

Automatic Flushing Units (AFUs) will be mandatory at all dead ends within the water distribution system. Based upon water modelling, AFUs will also be identified and required at any point within the water distribution system where minimal movement is noted. The connection to the water distribution system will be made with a 25mm copper water service and curbstop and drained to the sanitary sewer system. Other draining configurations will be reviewed on a case by case basis. The AFUs will be programmed and monitored by City staff to flush twice the required volume of water, three times per week. AFUs at dead end locations will remain connected to the water distribution system. Based on the proposed design, the AFU may be removed at full build out of the neighbourhood or at such time that water quality is maintained.

## 18.0 JOINTS, FITTINGS AND RESTRAINT DEVICES

### 18.1 General Requirements

All caps installed in new watermain shall be epoxy coated.

All connections, caps and bends shall be restrained by restrained joints. Concrete blocking shall be implemented as required. Concrete for thrust blocks complete with bond breaker shall be placed against undisturbed ground. Joints and couplings shall remain free from concrete. Joints and fittings shall be in accordance with OPSS and be NSF 61 & 372 certified.

### 18.2 Fittings

Fittings shall be suitable for and compatible with the respective pipe material, pressure rating and class with which they will be used. Watermain fittings are as shown in **Table 8**.

### 18.3 Joint Restraint Requirements

To prevent pipe movement and subsequent joint failure, joint restraints shall be designed to withstand the greater of the following: testing pressures; or transient pressures + normal operating pressures. All watermain placed within engineered fill must be fully restrained and extend a minimum of one pipe length into native ground.

Where pipe restraint is required, mechanical restraints shall be used. Thrust blocks shall be considered for use at tees, bends ( $\geq 45^\circ$ ), valves and caps.

All restraint distances shall be determined by the size of pipe, manufacturer and soil conditions and shall be identified on the engineering drawings in chart format. All restraints shall be designed to the following criteria:

- ML soil type
- 1.5 safety factor
- Type 5 trench class
- 200 psi test pressure
- Pipe material, fitting type and depth of bury as per individual scenario

Joint restraints for concrete pressure pipe will be as per those provided by the approved pipe suppliers. Thrust blocks shall be designed in accordance with OPSD.

WATERMAINS

# Construction

## CONSTRUCTION SPECIAL PROVISIONS — CONTRACT

### 19.0. PIPE REQUIREMENTS

#### 19.1 General

This section is in accordance with the provisions of OPSS, NSF 61 & 372. The pipe and appurtenances identified in this manual refer to conventional open cut installation methods.

The pipe size, type and class shall be as specified.

Fittings shall be suitable for and compatible with the pipe material and class with which they are used.

#### 19.2 Material Requirements

All materials in contact with drinking water shall meet all applicable quality standards set by the following:

- American Water Works Association (AWWA)
- Canadian Standards Association (CSA)
- NSF/ANSI Standard: Drinking Water – Health Effects

The pipe manufacturer's recommendations shall be incorporated into the design.

- Watermain, thrust blocks and restraints shall be selected such that they meet maximum of normal operating conditions and transients, or testing and commissioning pressures.
- Plastic bond breakers shall be 6 mm polyethylene
- These materials shall meet the requirements outlined in Table 8.

#### 19.3 Execution

##### — Excavations —

All excavations shall be done in accordance with the Occupational Health and Safety Act and Regulations for Construction Projects, Revised Statutes of Ontario, 1990 Chapter 1 as amended, most recent Ontario Regulation.

##### — Minimum Pipe Cover —

The watermain pipe and all water service pipe shall be installed or lowered so that the top of the pipe will be a minimum of 1.85 m and a minimum of 2.4 m below finished grade in an open ditch.

Additional depth may be required in areas where there is potential for conflict with other underground infrastructure.

Where the minimum specified cover cannot be achieved, sufficient insulation to prevent freezing of sections of watermain shall be provided as specified in the Watermain Design section and in the Contract Drawings and Standard Details.

##### — Maximum Length of Open Trench —

The maximum length of open trench when laying storm sewer shall be 90m or the distance necessary to accommodate the amount of pipe installed in a single day, whichever is smaller, or as specified by a Geotechnical Engineer.

The distance is the collective length at any location including open excavation, pipe length and appurtenant construction and backfill, which has not been completed.

The City's standard practice is for trenches to be backfilled at the end of each working day. In the event the City approves a trench to remain open overnight, at a minimum the trench must be completely enclosed with snow fencing and the pipe capped with a watertight seal cap, regardless of location, appropriate signage and notification.

##### — End of Day Installation —

At times when pipe laying is not in progress, the open ends of pipe shall be closed by a watertight seal. If water is in the trench, the seal shall remain in place until the trench is pumped completely dry.

### 19.3 Execution (cont'd)

#### — Pipe Laying and Jointing —

Proper equipment implements, tools and facilities shall be provided and used by the Contractor for the efficient laying of the pipe and the setting of the required fittings.

All materials shall be lowered into the trench in accordance with manufacturer's specifications.

Wherever it is necessary to deflect the pipe from a straight line either in the vertical or horizontal direction, the amount of deflection shall not exceed one (1) degree per joint. Restrained or mechanical joint bends are preferred.

#### **Pipe bending will NOT be permitted.**

Prior to the manufacture of any concrete pipe or fittings, the Contractor must submit to the City for its approval three (3) sets of piping layout and detail shop drawings. The shop drawings shall include complete dimensions and weights of pipe, details of manufacturing methods, materials to be used including material specifications, strengths, design calculations, spacing and size of struts, and other details such as are necessary to permit appraisal of the pipe.

#### — Cutting of Pipe —

The pipe shall be cut in conformance with pipe manufacturer's recommendations. Cutting of Asbestos Cement pipe shall be in accordance with the OHSA.

#### — Bedding, Embedment and Cover —

Bedding and cover material shall consist of ONLY Granular A. Bedding, cover and embedment materials shall meet OPSS & OPSD. Bedding and backfill materials shall be placed for the full width of the trench and mechanically compacted to 98% SPMDD, as determined by ASTM D698.

Where specified, concrete encased pipe crossings shall be completed with unshrinkable backfill. Unshrinkable backfill shall have a compressive strength of 0.4 MPa at 28 days. Width of unshrinkable fill shall cover the full width of the trench; the length shall extend 0.5m beyond the O.D. of the crossing pipe, and extend from 0.3m below the bottom of the lower pipe, to the bottom of the upper pipe. Bond breaker shall be supplied between all pipe materials and unshrinkable fill.

#### — Backfill —

Backfill shall be considered as starting at 300 mm above the watermain. All materials below this point shall be considered as bedding and cover or embedment material.

Backfill for structures such as valve chambers shall start at the sub-grade for the structure and will be brought up simultaneously and equally on all sides of the structure, as specified in OPSS.

All backfill material shall be placed and compacted according to OPSS.

All stones over 100 mm shall be removed and disposed of. All backfill materials shall be compacted to 98% SPMDD, in accordance with ASTM.

Care shall be exercised during backfill operations so that the watermain is not damaged or displaced.

Trenches may be backfilled with select, approved native excavated earth materials, or approved granular material meeting OPSS.

#### — Horizontal and Vertical Separation —

Clearances between watermains, sanitary and storm sewers shall be in accordance with MECF Procedure F-6-1: Procedures to Govern the Separation of Sewers and Watermains.

### 19.3 Execution (cont'd)

#### — Support of Watermains and Services —

At any point where a sewer, house connection, catch basin lead, new watermain or water service installed crosses below any existing watermain or service, the Contractor shall be required to provide a sealed drawing of all temporary shoring and bridging considered necessary on review by the City prior to installation. The Contractor must incorporate recommendations of the pipe manufacturer.

No supporting structures shall be permanently placed under watermains or services and the trench shall be backfilled and compacted to ensure that no future settlement occurs.

In the event that a cast iron watermain is fully exposed, the trench shall be backfilled with a non-shrinkable backfill material to a point not less or more than centre of the watermain.

The non-shrinkable backfill strength shall not be greater than 0.4 MPa. Any exposed asbestos cement pipe encountered shall be replaced with PVC pipe and associated appurtenances.

#### — Special Pipe and Material Installation Methods —

Where special methods for installation are proposed to be used, (e.g. tunnelling, micro-tunnelling, jack and bore) drawings and specifications must be submitted with the overall design.

### 19.4 Measurement for Payment

Measurement for payment shall be by length of pipe supplied and installed in linear metres.

## 20.0 TESTING AND COMMISSIONING

### 20.1 General

This section is in accordance with MECP Procedure for Disinfection of Drinking Water in Ontario.

Where watermain pipe has been allowed to be installed, capped and not connected to the City's water system, the pipe will be subject to independent swabbing, disinfection and bacteriological testing prior to any extension or modification. This section may potentially be subject to removal at the discretion of the City.

### 20.2 Material Requirements

In accordance with the Testing and Commissioning section of this manual.

### 20.3 Execution

In accordance with the Testing and Commissioning Section of this manual.

### 20.4 Measurement for Payment

Measurement for payment shall be per linear metre for all permanent water systems. Temporary water supply testing and commissioning shall be included in the appropriate tender item.



### 21.0 CORROSION PROTECTION

#### 21.1 General

This section shall be in accordance with the provisions of OPSS.

#### 21.2 Material Requirements

##### — Two-Part Petrolatum Coating System —

All material for two-part petrolatum coating systems shall be in accordance with OPSS and AWWA.

##### — Cathodic Protection —

Zinc anodes shall be 5.5 or 11 kg Packaged Zinc Anodes. This anode shall be manufactured using a High Purity Zinc 99.99% pure conforming to ASTM B-418-73 type 11.

The anode must have a metallic core, or fusion bonded sleeve and have a depolarizing gypsum base material surrounding the anode. The anode must be connected using the cadweld method, in accordance with the manufacturer's specifications. When fittings are epoxy-coated, the anode must be connected to the fitting's bolts so as to avoid damaging the coating.

Anodes shall be connected on valves, fittings, and hydrants using the 'cadweld' method and in accordance with the manufacturer's recommendations and specifications.

An insulated copper (AWG 10-14) wire 3.0 metres in length shall be brazed to the end of the core wire.

The following are specified anode sizing:

- Valves and Hydrants, Watermain Fittings (if PVC watermain is used), Water Services, Curbstops, Mainstops and Saddles between 38 mm and 50 mm – 11 kg
- Water Services, Curbstops, Mainstops and Saddles less than 38 mm – 5.5 kg

#### 21.3 Execution

Component	Petrolatum System	Cathodic Protection
Buried Metallic Fittings – on flanged surfaces, nuts, bolts, tie rods, clamps, valves, sleeves and couplings	Required	Required
Mechanical Restraints	Required	Not Required
Valve Chambers – surface of pipes, valves and appurtenances	Required	Not Required
Metallic Watermain – at each metallic component, curb stops, service saddles and on lateral piping of hydrants	Not Required	Required
PVC Watermain – 1.0 m horizontally from each metallic component	Not Required	Required

#### 21.4 Measurement for Payment

Payment for Corrosion Protection shall be included in the per linear metre payment for all permanent watermain installations and all water service installations.

## 22.0 TRACER WIRE

### 22.1 General

This section is in accordance with the provisions of OPSS.

Tracer wire shall be installed on all non-conductive watermains, hydrant laterals and water services except where such water service pipe is of copper material.

The wire shall be installed in such a manner as to be able to properly trace all watermains, hydrant laterals and water services without loss or deterioration of signal or without the transmitted signal migrating off the tracer wire.

### 22.2 Material Requirements

Tracer wire shall be TWU, number eight (8) gauge, stranded, insulated copper wire with 60 mil of white, cross-linked polyethylene (PEX) insulation specifically manufactured for direct burial applications.

All tracer wire welds onto existing cast or ductile iron pipe shall be completely sealed with the use of a Royston Handy Cap IP lubricated assemblies or approved equivalent.

In all cases, the pipe is to be properly cleaned and material applications shall be according to the manufacturer's instructions.

All spliced or repaired wire connections in the tracer wire system shall be made using a Dryconn Waterproof Connector or a Model Number 454, Catalogue Number 30-454, Wing Nut Wire Connector (for two to four #8 wires), or approved equivalent and made waterproof using an approved buried service wire closure.

The buried service wire closure shall be either a Klik-It II Number C8816 Buried Service Wire Closure or a Raychem GHFC-2-90 H-Frame Gel Closure or approved equivalent.

Test boxes, as part of the tracer wire system, shall be installed close to the hydrant or location specified on the Contract Drawings.

### 22.3 Execution

At the point of connection between cast or ductile iron watermains, with any non-iron watermain, the tracer wire shall be properly connected to the iron pipe with a cadweld method.

Tracer wire shall be laid flat and securely affixed to the pipe at three metre intervals. The wire shall be protected from damage during the execution of the works.

No breaks or cuts in the tracer wire or tracer wire insulation shall be permitted. At water service saddles, the tracer wire shall not be allowed to be placed between the saddle and the watermain.

Except for approved spliced-in connections, tracer wire shall be continuous and without splices from test box to test box.

At fire hydrants, no spliced-in tracer wire connections shall be allowed regardless of the type of material of the hydrant lateral. The main line tracer wire shall follow and be secured to the hydrant lateral up to and back from the hydrant and then continue along the watermain.

The tracer wire on a distribution main shall be installed inside a test box behind the hydrant at grade. The tracer wire on a transmission main shall be installed inside a test box clearly marked within the boulevard at grade. All installations must be provided with at least two metres of slack in the tracer wire above grade. In the event of multiple watermain's tracer wire being present within the test box, each line must be clearly labeled to avoid confusion.

### 22.3 Execution (cont'd)

At existing iron or copper water service connections where any portion of the water service is replaced with a non-ductile iron or non-copper material, a water service tracer wire shall be spliced into the watermain tracer wire and then connected to, the remaining iron water service by means of a cadweld, or the remaining copper water service using a ground clamp sized appropriately for the copper pipe.

At water service connections where there is no tracer wire on the existing watermain and the water service connection is neither iron nor copper pipe, tracer wire shall be cadwelded to the watermain tee or tapping valve and placed along the water service to a point where the water service enters inside the building.

For directional drilling, augering and jack and bore installations, four #8 tracer wires shall be installed with the pipe and connected to the tracer wire at both ends, or cadwelded to the existing iron pipe at both ends.

When a watermain passes through a valve chamber, the associated tracer must continue with the pipe through the chambers with no break or junction box termination.

### 22.4 Tracer Wire Report

A report confirming the tracer wire conductivity from all newly installed test boxes to the existing watermain exists shall be completed. The report will include a schematic demonstrating equipment used, signal strength, a detailed report of the testing procedures, the testing direction on all main line watermain and watermain connections from each test box within the project. Minimum signal strength of 8kHz required.

### 22.5 Measurement for Payment

Payment for Tracer Wire shall be included in the per linear metre payment for all non-conductive permanent watermain installations, non-conductive water service installations, and per each hydrant installation. A lump sum payment shall be provided for conducting the tracer wire

continuity test, and submission and approval of the Tracer Wire Report.

## 23.0 SERVICE CONNECTION REQUIREMENTS

### 23.1 General

This section is in accordance with the provisions of OPSS, NSF 61 & 372. Fittings shall be suitable for and compatible with the pipe material and class with which they are used. Service connections shall be nominal diameter of 25 mm, 38 mm, 50 mm or 100 mm pipe.

75 mm services are not permitted. Service connections with a nominal diameter of less than 15mm are obsolete. All water services shall be a minimum of 25 mm to property line.

### 23.2 Material Requirements

#### — Service Connection Pipe —

Service connection pipe shall be approved Type 'K' soft copper, nominal diameter of 19mm (only for cut, extend and reconnect), 25 mm, 38 mm or 50 mm. Kinked, crushed or distorted tubing shall not be used. Only compression type fittings are to be used between the watermain and the water meter.

Approved crosslinked 25 mm polyethylene (PEX) pipe is permitted in new residential developments from watermain to water meter only in accordance with CSA, NSF 61 & 372 and ASTM, complete with a tracer wire.

PVC pipe is preferred for 100 mm diameter and larger water services.

#### — Corporation Stops —

Corporation stops are required to use No-Lead brass and be in accordance with CSA and NSF 61 & 372. Corporation stops for 25 mm, 38 mm, or 50 mm diameter water services shall have AWWA inlet thread and compression style outlet unless corporation stop is integrated with saddle. Only "ball type" corporation stops are approved by the City. Where an anode connection is shown, an electrical ground connection tailpiece shall be used.

### 23.2 Material Requirements (cont'd)

#### — Curb Stops —

Curb stops are required to use No-Lead brass and be in accordance with CSA, NSF 61 & 372. Only “ball type” curb stops are approved by the City and shall come complete with an electrical grounding clamp for attachment of the anode.

#### — Service Boxes —

The service boxes shall be for 1.7 m to 2.0 m bury, but shall be extended if special depths are encountered. Slide service boxes require type 304 stainless steel rods and stainless steel cotter pins.

#### — Service Saddles —

Service saddles shall be used on all services installed off of PVC, PVC0 and asbestos cement watermain and on all services larger than 25 mm installed off of ductile iron watermain. All service saddles will require a double bolt closure.

### 23.3 Execution

A service connection and its appurtenances shall be installed in accordance with the latest versions of MECP guidelines and OBC. Location of curb stops in driveways and walkways shall be avoided.

The performance of wet taps requires the onsite supervision by a licensed operator. All water services must be jumpered before renewal.

#### — Service Connections < 38 mm —

Installation of all service pipes, stops, and goose necks shall be as per detail **W-201**, in standard drawings and details section of this manual.

No relocated water service shall be allowed to pass within 1.2 m of any catch basin or storm sewer manhole or within 0.3 m of a sanitary manhole. Any existing water service must be relocated to comply with this requirement.

All water services beyond the water meter shall be constructed in accordance with the OBC.

#### — Service Connections 38 mm & 50 mm —

Installation of all service pipes and stops shall be as per detail **W-202**, in standard drawings and details section of this manual.

Corporation stops, curb stops, couplings, service boxes and service saddles shall be installed as recommended by the manufacturer of the service connection pipe.

All water services beyond the water meter shall be constructed in accordance with the OBC.

#### — Service Connections ≥ 100 mm —

The connection of any proposed watermain or water service with a diameter one standard size down from the existing watermain shall be made using a cut-in tee and valve. Services two standard sizes down can be made using a tapping sleeve.

#### — Curb Stop and Service Box —

The service boxes shall be for 1.7 m to 2.0 m bury (regardless of size), but shall be extended if special depths are encountered.

Existing service boxes shall be left in good condition by the Contractor. The top shall be at ground level so as not to cause a hazard. When paving and sodding, the tops shall be lifted to new finished grade.

A curb stop and box must be installed and the box must be plumb. An anode shall be attached to the curb stop at the grounding tail piece connection.

### 23.3 Execution (cont'd)

The connection to the obsolete water service shall be made with a coupling and not with the curb stop. A short piece, approximately 300 mm to 600 mm of copper, shall be extended past the curb stop on the private side completing the connection to the obsolete water service with a coupling. The connection shall be made at the property line.

#### — Service Connections to Supply Main —

Connections to existing watermains shall be completed in accordance with the Testing and Commissioning section of this manual. Private service connections will not be permitted on the transmission main.

#### — Existing Service Removals —

Obsolete water services, valves and curb stops must be removed from the main to preserve water quality, prevent leaks and avoid confusion. In the case of a tee, it is to be removed and a filler piece is to be installed.

### 23.4 Measurement for Payment

Measurement for payment shall be by length of service pipe in linear metres.

## 24.0 HYDRANTS

### 24.1 General

This section is in accordance with the provisions of OPSS, NSF 61 & 372.

### 24.2 Material Requirements

All hydrants and hydrant risers shall be dry-barrel type and shall conform to the latest revision of CSA and AWWA. Wet barrel hydrants shall not be permitted.

Hydrants in the right of way shall be painted yellow and private hydrants shall be painted red. All hydrants shall be complete with Storz connections.

Hydrants shall be located on lot lines and 2.0 m

horizontal clearance from edge of driveway.

The inside of hydrant boots shall be epoxy coated. Hydrants to be installed within 75 mm from finished grade to the breakaway flange.

### 24.3 Execution

Hydrants shall be connected to the main with an anchor tee complete with independent gate valve. Hydrant leads shall be equivalent in size to the 150 mm hydrant inlet.

The hydrant barrel shall have a minimum depth of 1.85 m. 19 mm clearstone with geotextile wrap for adequate barrel drainage and poured thrust blocking shall be provided.

The hydrants shall be installed plumb and positioned so that the hydrant nozzles are parallel to the street line.

### 24.4 Hydrant Classification

Colour coded pressure rings must be placed on both side ports of hydrant following installation. Refer to [section 15.3](#) for requirements.

### 24.5 Measurement for Payment

Measurement for payment shall be by number of hydrants installed.

## 25.0 VALVES AND CHAMBERS

### 25.1 General

This section is in accordance with the provisions of OPSS, NSF 61 & 372.

All valves in contact with drinking water shall comply with AWWA and be NSF 61 & 372 certified. Valves (100 mm to 300 mm) shall be mechanical jointed, unless otherwise specified and must open clockwise.

All valves on distribution and transmission mains are to be direct buried. Valve chambers will be considered on a case-by-case basis. Chambers are required for air release and drain valves.

### 25.1 General (cont'd)

Only licensed City operators can operate valves. They shall provide a minimum two (2) working days' notice to coordinate any required shut down and mobilize to site.

### 25.2 Material Requirements

All material for valve and boxes shall be NSF 61 & 372 certified and in accordance with OPSS.

All valve chambers shall be provided with adequate thrust restraint, approved waterproofing, sealed joints and insulated above the frost depth.

Where piping at valve chambers transition from PVC or PVCO to ductile iron, the transition shall be made by use of couplings outside of the chamber walls as per the standard drawings.

### 25.3 Execution

Wherever possible, valve boxes shall not be located within the vehicle wheel paths of the roadway.

The valve box tops shall be at ground level and accessible so as not to cause a hazard. When paving or sodding, the tops shall be lifted to the new finished grade. The use of pavement levellers for valve boxes will not be allowed.

All existing valves and associated boxes shall be left in good condition by the Contractor. Any boxes, valves or other appurtenances damaged by the Contractor shall be restored with new and equal materials to the satisfaction of the City. All new and existing valves must be accessible for operation at all times.

Approved valve extension rods shall be installed as required when the distance between the top of the operating nut and the proposed final grade exceeds 1.2 m.

Extension stems shall be a 25 mm solid square bar.

All services boxes in the roadway shall be enclosed using a valve box top section and lid.

Valve chambers located in gravel shoulders shall be provided with a paved area sufficient for parking one vehicle. See detail **A-101** in the standard drawings section of this manual.

### 25.4 Measurement for Payment

Measurement for payment shall be by number of valves and valve chambers installed by type and size.

## 26.0 JOINTS, FITTINGS AND RESTRAINT DEVICES

### 26.1 General

All connections, caps and bends shall be restrained by restrained joints. Concrete blocking shall be implemented as required. Concrete for thrust blocks complete with bond breaker shall be placed against undisturbed ground. Joints and couplings shall remain free from concrete. Joints and fittings shall be in accordance with OPSS and be NSF 61 & 372 certified.

### 26.2 Material Requirements

Fittings shall be suitable for and compatible with the respective pipe material, pressure rating and class with which they will be used. Watermain fittings are as shown in **Table 8**.

All concrete pressure pipe and pipe joints will be diapiered using high sulfate cement as specified by the manufacturer.

Caps and plugs shall be epoxy coated on the inside. Epoxy coating shall be NSF 61 & 372 certified.

### 26.3 Execution

Adequate restraints for watermains shall be provided to withstand the the greater of the following: testing pressures; or transient pressures + normal operating pressures. All watermain placed within engineered fill must be fully restrained and extend a minimum of one pipe length into native ground.

Where pipe restraint is required, mechanical restraints shall be used. Thrust blocks shall be considered for use at tees, bends ( $\geq 45^\circ$ ), valves, caps and permanent connections unless otherwise approved by a City Inspector.

All restraint distances shall be determined by the size of pipe, manufacturer and soil conditions and shall be identified on the engineering drawings in chart format. All restraints shall be designed to the following criteria:

- ML soil type
- 1.5 safety factor
- 5 trench class
- 200 psi test pressure
- Pipe material, fitting type and depth of bury as per individual scenario

Thrust blocks shall be designed in accordance with OPSS.

### 26.4 Measurement for Payment

Payment for Joints, Fittings and Restraint Devices shall be included in the per linear metre payment for all permanent watermain installations and water service installations.

## 27.0 TEMPORARY WATERMAINS AND SERVICING

### 27.1 General

This section is in accordance with the provisions of OPSS, MECP and NSF 61 & 372.

In the event of scheduled water disruptions to users >12 hours, a temporary distribution system may be required. All shutdowns must be

fully approved by the City.

A schematic of the Temporary Bypass Lines including services, valves, hydrants and other appurtenances must be submitted for approval. The Temporary Bypass Lines will be fed from the existing watermain through a disinfected "RPZ" (Reduced Pressure Zone) backflow preventer. Proof of calibration of the RPZ must be submitted prior to every installation. The RPZ backflow preventer and meter will remain in place for the duration that the Temporary Bypass Lines are in service.

The Temporary Bypass lines will have to pass the City's disinfection procedure and bacteriological test as outlined in Testing and Commissioning section of this manual prior to any water services being connected.

The Contractor shall maintain the City operating pressure in the temporary water service lines which shall be maintained in a safe operative condition at all times and shall be responsible for the prevention of injury to persons and damage to property. The Contractor shall provide safeguards, but such provisions shall not relieve the Contractor of full responsibility for the adequacy of protection.

### 27.2 Material Requirements

The Contractor shall supply, install and maintain temporary watermain bypass, services, RPZ backflow preventer and meter to facilities and properties that are affected in the construction.

The Contractor shall supply and install all necessary fittings including tee, bends and sleeve to complete the connection between the temporary bypass watermain and the existing water service.

All temporary watermain and servicing materials shall be NSF 61 & 372 certified.

All materials will be delivered and capped new to the site or used material will be pressure washed and capped at the site prior to installation.

## 27.2 Material Requirements (cont'd)

### — Temporary Water Servicing —

All temporary service connection materials shall be NSF 61 & 372 certified. All hose used for each individual property connection shall be a minimum 19 mm internal diameter, designed for a working pressure of 860 kPa and be free from defects in material and workmanship.

The pipe, hose and all other materials which are to be furnished by the Contractor for use in conjunction with the temporary service pipe and temporary connections to property services and branches shall be approved by the City and shall be of material which does not impart any taste or odour to the water in accordance with NSF 61 & 372.

### — Temporary Hydrants —

The Contractor shall supply, install and maintain temporary fire hydrants and the necessary valves and fittings to replace all existing within the construction site; these temporary hydrants shall be connected to minimum 100 mm diameter bypass pipe and placed in locations as instructed by the City.

The temporary hydrants shall be 62 mm nozzles with 5-threads per 25 mm complete with cap. The operating nuts shall be 32 mm square.

## 27.3 Execution

### — Temporary Water Servicing ( 19 mm - 50 mm ) —

It shall be the responsibility of the Contractor to ensure an adequate water supply at all times. During the construction process, the Contractor will be responsible to restore a customer's water supply within a two (2) hour time period upon notification from the City.

Pipe and fittings shall provide adequate water tightness and care shall be exercised throughout the installation of any temporary pipe. Flushing of the private service connections and chlorination of the bypass line prior to their use will be required.

The temporary service connections shall be valved near the point of connection to the Temporary Bypass Line. Disinfect the new pipe and fittings by spraying the new pipe and fittings with NSF 60 approved liquid chlorine solution.

Access to private properties must be accompanied by the City.

### — Temporary Water Servicing ( ≥ 100 mm ) —

Supply and install all necessary fittings including tee, bends and sleeve to complete the connection between the temporary bypass watermain and the existing water service.

The temporary service connections shall be valved near the point of connection to the Temporary Bypass Line. Disinfect the new pipe and fittings by spraying the new pipe and fittings with NSF 60 approved liquid chlorine solution.

### — Temporary Hydrants —

The hydrants will be set in such a manner that the Fire Department will have no difficulty making a connection with a fire hose and where they will cause least obstruction to vehicular and pedestrian traffic and will be least likely to be damaged. Temporary fabricated fire hydrants are acceptable.

A detailed sketch of the hydrant the Contractor proposes to use must be submitted prior to commencement of work.



### 27.3 Execution (cont'd)

#### — Temporary Hydrants (cont'd) —

All temporary hydrants, valves, fittings, service pipes and all other material shall be adequate to withstand the pressures and conditions of use. Before permanently shutting down the watermain, the Contractor shall test all temporary hydrants and valves to ensure that they are in proper working order.

All temporary hydrants must have reflective tape on the barrel for increased visibility. The temporary hydrants must stand in an upright position at all times. Once put into use, the temporary hydrants shall be maintained until the existing hydrants are restored to service. The hydrants which are out of service during construction operations shall be bagged. The bag shall be clearly marked "Hydrant Out of Service".

#### — Burying Temporary Bypass Watermains —

The Contractor shall cut and remove asphalt across streets to permit burying the bypass pipe and shall replace the asphalt when the pipe is removed.

Under no circumstance is a pipe road crossing to remain open and unprotected from vehicular and pedestrian traffic.

All driveway crossings shall be ramped with cold mix to protect the pipe and to provide access to private property.

#### — Disinfection of Temporary Bypass Watermains and Water Services —

Disinfection shall be in accordance with the Testing and Commissioning section of this manual.

All temporary bypass lines and service connections shall be disinfected by the Contractor under the supervision of the City.

### 27.4 Measurement for Payment

Measurement for temporary watermain and servicing shall be a lump sum item.

WATERMAINS

# Development

## DEVELOPMENT

This section outlines the minimum requirements to aid the Developer in the implementation of water transmission and distribution systems in the City.

The Developer shall design and construct the water systems for private developments in accordance with this manual as well as other industry standards and best practices.

### 28.0 WATER SERVICE CONNECTION PROCEDURES

#### 28.1 General

Prior to any new connection to City's existing system, all developers or owners shall provide verification in writing of the existence of any well connections.

#### 28.2 Services Connections $\leq$ 50 mm

- The Owner will be required to supply engineering site servicing drawings for services under or equal to 50 mm for review.
- The City will review all applications for any applicable service charges, including, but not limited to, frontage charges, pre-servicing charges and connection fees as part of the Water Service Connection Permit Application.
- All applicable charges will be applied to the customer's initial water bill.
- An inspection fee will be charged for each visit required to complete the inspection process, (fees are set according to the City's schedule of Fees & Service Charges).

#### 28.3 Services Connections $>$ 50 mm

- The water service permit applicant must first contact the City's Customer Service Department.
- The owner is to supply the City with engineering site servicing drawings, design flows for both domestic and fire water demands and metering requirements.

- In accordance with the City's schedule of Fees & Service Charges, the actual cost will be determined and charged for review and inspections upon issuance of permit.
- Check valves are to be supplied on all service connections  $>$ 50mm.

#### 28.4 Water Meters

**NOTE:** All water meters used must be **CITY SUPPLIED**.

As per the City's by-laws for water rates, applicable fee will be charged prior to the installation of any water meter.

- City water meters will not be issued until the water service has been inspected and approved by the City.
- The meters shall be a minimum of one size smaller than the size of the water service. Domestic water demands have to be submitted to support the meter size required.
- The meter shall be installed on the service immediately after it passes under the footing and is brought up through the floor.
- All meters will be sealed by the City at the time of installation.
- Fees for the water meter will be charged to the property owner in conjunction with the Water Service Connection Permit (fees are set according to the City's schedule of Fees & Service Charges).

### 29.0 MAINTAINING WATER QUALITY

Where dead-ends and any potential for water quality issues are deemed to exist, Automatic Flushing Units (AFU's) must be installed to maintain water quality and chlorine residuals unless otherwise approved by the City. The volume of water required to be circulated will be equal to 2x the volume of water flushed 3x per week.

WATERMAINS

# Testing and Commissioning

## TESTING AND COMMISSIONING

### 30.0 GENERAL

This section provides an overview of Testing and Commissioning requirements on all watermain projects in the City. Commissioning is to be carried out by a certified Third Party Agent. This agent shall have the proper equipment and a minimum of five (5) years of professional experience to perform the disinfection, swabbing, pressure testing, and commissioning of watermains. Additionally, documentation confirming these qualifications shall be provided to the City upon request. Forms required during the Testing and Commissioning phase are included in this manual. This section is in conformance with, and/or exceeds the MECP Watermain Disinfection Procedure Document.

#### *30.1 Watermain Commissioning Plan*

Contractor must submit approved Watermain Commissioning Plan on the [City's template](#). This must be reviewed and approved by the City prior to any watermain installation occurring.

### 31.0 INSPECTION

Following approval of the submitted Watermain Commissioning Plan the City will require a minimum of two (2) full working days' notice by the Contractor for inspection.

Connection of any watermain or service to the City's water distribution system must be inspected or supervised by the City.

### 32.0 SHUTTING DOWN OR CHARGING WATERMAINS

Operation of valves and hydrants is to be performed by a Licensed City Operator. Advance notice of at least two (2) full working days is required by the City when valve operation is necessary.

Where depressurization of a watermain with no users occurs prior to an air gap being established, the Developer shall repeat swabbing, disinfection and testing procedures at the discretion of the City.

### 33.0 BACKFLOW PREVENTER

The watermains will be isolated from the existing water distribution system using a physical separation until satisfactory bacteriological testing, results and final connection have been completed. The separation will be accomplished by using a temporary connection consisting of a RPZ backflow preventer.

NOTE: The City will NOT be providing any water meters or RPZ backflow preventers for the purpose of system separation.

The City will require a copy of the written certificate of the backflow preventer operation in accordance with CSA / Ontario Building Code standards. The Backflow tester must have a Cross Connection Control Specialist License from OWWA or ministry-approved equivalent. ASSE International certification is acceptable. (American Society of Sanitary Engineering).

### 34.0 PROCEDURE FOR WET TAPS ON WATERMAINS

- Performance of Wet Taps must be inspected or supervised by the City.
- No tapping is allowed within 1.0 m of a joint or other tapped service.
- The Surface Shall be cleaned & prepared with an NSF 60 certified chlorine solution. The surface shall be free from all debris, oil and grease.
- The City shall inspect the tapping machine prior to the tap being carried out, to ensure it is in good working order and is equipped with a proper well-maintained cutter.
- The portion of the tapping machine that comes in contact with the watermain must be clean and free of any dirt or grease
- The portion of the machine that will enter the watermain during the tap MUST be properly disinfected with NSF 60 certified chlorine solution (between 5% - 12%), from a clean, labelled and

sealed bottle, prior to tapping the main.

- Adhere to manufacturers' instructions on pipe material and the operation of the tapping machine.
- After the tap is complete, removal of the coupon must be evident on the bit. The main stop and/or valve must be flushed prior to connecting the service line.

### 35.0 SWABBING AND TESTING

All swabbing and testing must be inspected by the City.

#### 35.1 Pressure and Leakage Test

Hydrostatic pressure and leakage tests shall be inspected by the City.

Prior to testing, watermain test sections shall be filled with water slowly, making sure all air is removed from the watermain and allow for a 24 hour period before starting the pressure testing procedure.

All pressure testing procedures must be continuous at 1379 kPa (200 psi) for 2 hours. Maximum testing pressure shall not exceed 235 psi unless otherwise approved by the City and pipe manufacturer.

Temporary watermains are exempt from pressure testing requirements.

Tests are satisfactory if pressure is maintained with no pressure drop and leakage is not greater than 0.000041 L / mm diameter of pipe / m of pipe installed / hour in accordance with OPSS.



#### 35.2 Swabbing

The Contractor will be required to install swab launchers at every extremity of water mains, temporary watermains and services  $\geq 50\text{mm}$ , as well as at all watermain stubs without limitation on the length. All hydrants are to be swabbed prior to disinfection, including those that are recycled.

- Three (3) soft foam swabs are to be used for swabbing each watermain installation, including hydrant leads and barrels.
- Swab size for watermain ( $<150\text{mm}$ ) shall be one (1) size bigger than the pipe size. Swab size for watermain ( $\geq 150\text{mm}$ ) shall be two (2) sizes bigger than the pipe size. New swabs must be supplied for each procedure. All swabs must be consecutively numbered and provided to the City following completion of the swabbing.
- Fill the watermain and allow it to sit a minimum of 24 hours before proceeding with swabbing to saturate and loosen any deposits in the main.
- Propel the swab with potable water at a rate of 0.5 to 1.0 m/sec.
- At the end of the swabbing process, each watermain stub including fire hydrant leads and discharge point must be flushed to maintain the prescribed flow rate until water runs clear for at least five (5) minutes and to achieve  $< 1.0$  NTU or equivalent to the source water.
- Continue swabbing until the discharge water runs clear of the last swab exiting the discharge point.
- Control discharge water to an acceptable outlet and ensure siltation and dechlorination requirements are met.
- Swab launchers will remain connected to the new watermain until the bacteriological samples have successfully passed.

### 35.3 Disinfection

Following the successful pressure and leakage test and swabbing, proceed to chlorinate the watermain with all chlorine compounds, piping,

pumps and labour for proper disinfection. The chlorine compound used must be liquid sodium hypochlorite NSF 60 and shall be introduced in sufficient concentration.

The initial free chlorine concentration in the watermain and all extremities shall reach a minimum of 100 ppm and not to exceed 150 ppm. Due to reaction to high chlorine concentrations, copper services should be subjected to no more than 50ppm. The chlorine concentration at the designated sampling locations will be measured and recorded right after chlorination and compared to the levels measured 24 hours later.

Two conditions must be fulfilled after a twenty-four (24) hour waiting period:

- The final chlorine residuals measured at each sampling location should not drop by more than 30% up to a maximum decrease of 50 mg/L from their initial readings (copper pipes connected to watermains are exempt); and turbidity must be under 1.00 NTU
- After chlorinating, flush the watermain with potable city water. Dechlorinate the water with an approved dechlorination agent prior to discharging to the approved outlet. The Contractor must supply the City with documentation regarding the method of dechlorination for approval. Dechlorination must achieve chlorine levels below the minimum detection limit. (0.02 ppm)

Flushing should continue until chlorine residuals and turbidity levels are consistent with the quality of City water directly upstream of the new watermain.

### 35.4 Bacteriological Sampling

After a watermain ( $\geq 50$ mm) has been properly

disinfected and flushed, the City will request that bacteriological samples be taken within one (1) full working day's notice at the designated locations.

Bacteriological samples must be scheduled between 8:30 and 15:00 Monday to Thursday and up to 12:00 Friday. Two sets of bacteriological samples will be collected 24 hours apart after final flushing. During the bacteriological sampling period, the Contractor shall not remove any water from the watermain being tested.

If any contamination has occurred in the new watermain during construction, or if, in the opinion of the City's Inspector, excessive quantities of dirt have entered the main, bacteriological samples shall be taken at intervals of approximately 60 m.

Each sampling location must comply with the following before a bacteriological sample will be collected:

- Turbidity must be under 1.00 NTU.
- The chlorine residuals measured during bacteriological sampling shall never drop by more than 50% compared to the results obtained after final flushing (copper pipes connected to watermains are exempt).
- Aesthetic parameters will be similar to the source water (colour, taste & odour similar to the City's water supply).
- If one sampling location does not meet the above standards, none of the bacteriological samples will be submitted for testing.

### 35.4 *Bacteriological Sampling Cont'd*

#### — Sampling Points—

Water samples will be taken on the new watermain or temporary supply line by the City from sampling points along the length of the watermain with a maximum 365m between sample points, at each branch and every fire hydrant with a lead longer than 6m prior to the main or temporary supply line being put into service.

The Contractor shall provide a new copper sampling line from the main including a new shut-off at the end of the line. These sampling lines must be disinfected using NSF 60 certified solution.

All sampling point locations to be pre-approved by the City.

### 35.5 *Bacteriological Analysis*

Two sets of bacteriological samples will be collected at a minimum of 24 hours apart after flushing; one at 0 hour and one at 24 hour.

Bacteriological tests will consist of 24 hour membrane filtration (total coliform, e-coli, background) which will be analyzed by the City's laboratory.

It will take a minimum of 72 hours to obtain the final results of the bacteriological samples.

Each sampling location must comply with the following bacteriological standard requirements:

- No total coliform or e-coli must be detected.
- Background shall not exceed 10 colonies per 100 ml.

Should the first round of samples fail, the Contractor shall, at a minimum, re-flush the watermain, prior to samples being retaken. Should the samples fail again, the watermain must be re-swabbed, re-chlorinated and re-flushed, prior to samples being retaken.

Should the samples continue to fail, the City and Contractor will work together to determine the corrective action.

### 36.0 FINAL CONNECTION

The Contractor shall NOT complete any permanent connection until the City has given final approval.

The Contractor shall provide the City, two (2) full working days' notice before connecting to existing watermains.

Permanent connection to the City's existing watermain system shall be made within 14 calendar days of successful bacteriological testing.

Where a final connection exceeds 6m in length, the pipe must be swabbed and chlorinated above ground.

The Contractor will be required to supply sufficient pumps to control the water flow during the connection. The Contractor shall ensure there is no contamination within the final connection.

All materials used for the final connection must be swabbed with an NSF 60 certified concentrated chlorine solution.

Following the permanent connection installations, the watermains will be flushed by the City and bacteriological samples will be taken.

Bacteriological samples must be scheduled between 8:30 and 15:00 Monday to Thursday and up to 12:00 Friday.



TESTING AND COMMISSIONING FORMS

WATERMAINS

# Testing and Commissioning Forms



## WATERMAIN COMMISSIONING PLAN

<b>PROJECT NAME:</b>	
<b>FROM - TO / DESCRIPTION</b>	
<b>CITY OF BRANTFORD CONTRACT NO.</b>	
<b>PROJECT OWNER</b>	
<b>CONTRACTOR</b>	
<b>COMMISSIONING AGENT</b>	
<b>DATE SUBMITTED</b>	
<b>ANTICIPATED DATE OF COMMISSIONING</b>	

### GENERAL NOTES:

The Watermain Commissioning Plan (WCP) applies to a wide range of watermain projects, including commissioning of trunk mains, distribution mains, or water services 50mm and greater. In addition;

- The WCP shall be submitted and approved by the City prior to any watermain installation and in accordance with the latest version of the [Linear Design and Construction Manual: Watermains, City of Brantford](#);
- The City does not provide water meters and backflow prevention devices for temporary connections to source watermains;
- Commissioning activities shall be carried out by a Certified Third Party Commissioning Agent (excluding all bacteriological sampling that must be performed by licensed City Staff; and
- Duplicate tables as needed.



## WATERMAIN COMMISSIONING PLAN

### 1. STAGING

The new watermain installed shall be pressure and leakage tested in \_\_\_\_\_ stage(s) comprised of the following areas:

STAGE	STREET	FROM	TO	CITY COMMENTS	INITIAL
DESCRIPTION - INCLUDING WATERMAIN SIZE(S), TOTAL LENGTH(S) AND STREETS					
DESCRIPTION - INCLUDING WATERMAIN SIZE(S), TOTAL LENGTH(S) AND STREETS					



## WATERMAIN COMMISSIONING PLAN

### 2. SAMPLE LOCATIONS

Sample points must be installed every 365m, at each branch and water service  $\geq 50\text{mm}$  and at each fire hydrant with a lead longer than 6m.  
Refer to the City of Brantford Design and Construction Manual Standard Drawing **W-317** for details.

STAGE	SAMPLE POINT NUMBER	STREET	STATION (x+xxx)	DISTANCE FROM SOURCE OR PREVIOUS SAMPLE LOCATION (m)	TYPE OF SAMPLE PORT	CITY COMMENTS	INITIAL



## WATERMAIN COMMISSIONING PLAN

### 3. TEMPORARY CONNECTION / WATER SOURCE

The watermain under test must be connected to the City's watermain distribution system for source water. A tested and certified RPZ backflow preventer shall be installed at every connection until satisfactory bacteriological testing, results and final connection have been completed.

TEMPORARY CONNECTION		CITY COMMENTS	INITIAL
Street (Name)			
Location (Station/Intersection)			
Source Watermain diameter (mm)			
Source Watermain Material			
Street (Name)			
Location (Station/Intersection)			
Source Watermain diameter (mm)			
Source Watermain Material			



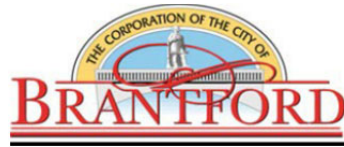

## 5 A. HYDROSTATIC TESTING

As a minimum, the hydrostatic test pressure of 1379 kPa (200 psi) shall be used and testing pressure shall not exceed 1620 kPa (235 psi), unless otherwise approved by the City and pipe manufacturer. Hydrostatic pressure testing shall be completed in accordance with the latest version of the Design and Construction Manual for Linear Municipal Infrastructure: Watermains, City of Brantford.

STAGE	PRESSURE TEST					CITY COMMENTS	INITIAL
	TEST POINT	STREET	STATION (x+xxx)	ELEVATION (m)	PRESSURE (kPa)		
	Test Pressure Application Point						
	High Point						
	Low Point						
	Test Pressure Application Point						
	High Point						
	Low Point						



**5 B. LEAKAGE TEST**

STAGE	LEAKAGE TEST		CITY COMMENTS	INITIALS
	Length of test section			
	Diameter of test section			
	Allowable leakage volume for Stage 1 for a 2 hour period			
	Length of test section			
	Diameter of test section			
	Allowable leakage volume for Stage 2 for a 2 hour period			

**LEAKAGE TEST** will be completed in the following manner and in accordance to the Design and Construction Manual for Linear Municipal Infrastructure: Watermains, City of Brantford:

1. Allowable Leakage Rate: 0.000041 l/mm dia/m/hr
2. Calculate amount of water prior to start of leakage test
3. Watermain pressurized to required test pressure
4. Every 15 minutes, re-pressurize the watermain to required test pressure
5. At the end of 2 hours, calculate amount of water used





## 6. DISINFECTION/TESTING

Following the successful pressure and leakage test and swabbing, the watermain will be chlorinated using liquid sodium hypochlorite NSF 60 and following the latest version of the Design and Construction Manual for Linear Municipal Infrastructure: Watermains, City of Brantford.

Bacteriological samples must be scheduled between 8:30 and 15:00 hours Monday to Thursday and up to 12:00 Friday (unless Friday is a holiday then the Thursday sampling schedule will be restricted between 8:30 and 12:00). Two sets of bacteriological samples will be collected 24 hours apart after final flushing. During the bacteriological sampling period, the Contractor shall not remove any water from the watermain being tested.

It will take a minimum of 72 hours to obtain the final results of the bacteriological samples.

Should the first round of samples fail, the Contractor shall, at a minimum, re-flush the watermain, prior to samples being retaken.

Should the samples fail again, the watermain must be re-swabbed, re-chlorinated and re-flushed, prior to samples being retaken.

Should the samples continue to fail, under the direction of the City, the City and Contractor will work together to determine the corrective action.



## 7. PERMANENT CONNECTION

Permanent connections must be made in dry conditions in the presence of the City. Upon completion of the connection, the main must be flushed from the hydrant/service. Before the permanent connection, a clear stone pump will be installed at least 500mm below the pipe inverts. A pump with sufficient capacity to expel water entering the trench shall be used. Caution will be taken to make sure that no dirt, debris or groundwater enters the open pipes. A Certified Operator-in-Charge with the City of Brantford will ensure that the connection is done properly and will perform a visual inspection for leaks under pressure prior to backfilling. The Sodium Hypochlorite shall be ANSI/NSF 60 or 61 certified as per the Water Treatment Plant Municipal Drinking Water Licence and a minimum of 1% solution shall be used according to the Ontario Watermain Disinfection Procedure. All pipes, fittings and appurtenances shall be sprayed with Sodium Hypochlorite solution before installation. All in accordance with the latest version of the Design and Construction Manual for Linear Municipal Infrastructure: Watermains, City of Brantford.

STAGE	PERMANENT CONNECTIONS		CITY COMMENTS	INITIAL
	Location			
	Type of connection			
	Gap to connect (m)			
	Connection details			
	Location			
	Type of connection			
	Gap to connect (m)			
	Connection details			
	Location			
	Type of connection			
	Gap to connect (m)			
	Connection details			



## 8. SAMPLE LOCATION LAYOUT

Attach a drawing(s) or sketch(s) for each stage showing the test pressure(s) at required locations, swab launcher location(s), retrieval location(s), swab travel route(s), sample point location(s), source feed location(s) and automatic flushing unit(s), where applicable.

### Commissioning Plan Review

Review of this plan does not relieve the proponent of its responsibility for compliance with the requirements of the Design and Construction Manual for Linear Municipal Infrastructure: Watermains and all other applicable regulations and guidelines.

Reviewed

Submission No.

Reviewed as Noted

Reviewed By:

Revise and Re-submit

Date:

WATERMAINS

# Detailed Engineered Cross-Sections

## DETAILED ENGINEERED CROSS-SECTIONS

Drawing No.	Title
H-101	Local Road, 18.5 m ROW Width, 7.8 m Road Width
H-102	Local Road, 18.5 m ROW Width, 10.2 m Road Width
H-102B	Local Road, 20.0 m ROW Width, 10.2 m Road Width
H-103	Minor Collector Road, 24.5 m ROW Width, 12.6 m Road Width
H-104	Minor Collector Road, 24.5 m ROW Width, 15.0 m Road Width
H-105	Major Collector Road, 27.5 m ROW Width, 18.2 m Road Width
H-105B	Major Collector Road, 27.5 m ROW Width, 14.7 m Road Width
H-106	Major Collector Road, 30.5 m ROW Width, 17.4 m Road Width
H-107	Arterial Road, 40.0 m ROW Width, 20.8 m Road Width
H-108	Arterial Road, 40.0 m ROW Width, 22.1 m Road Width
H-109	Industrial Minor Collector Road, 27.5 m ROW Width, 10.0 m Road Width

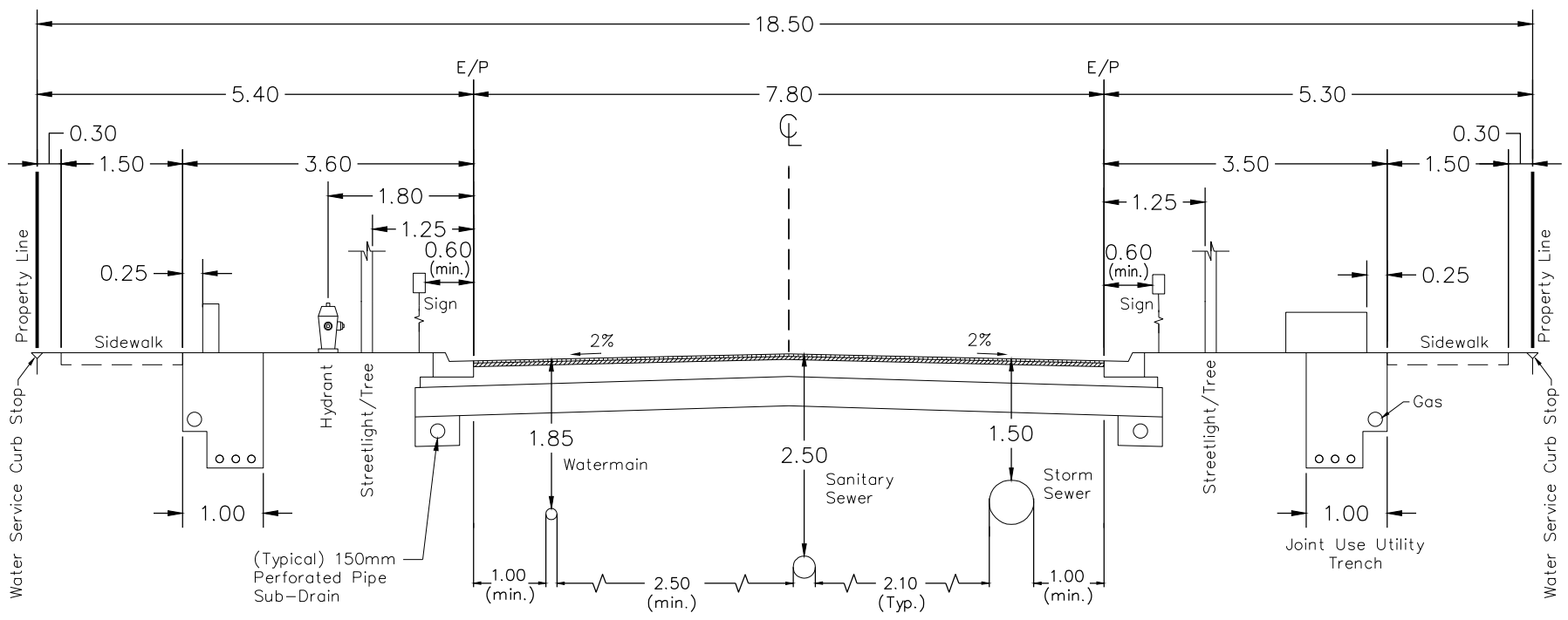

**DETAILED SECTION – LOCAL STREET**

N.T.S.

- NOTE: 1) All dimensions are in metres unless otherwise shown.  
 2) Curb and gutter to meet O.P.S.D. or City of Brantford detail drawing RD-104 for two-stage curb construction in accordance with project drawings  
 3) Road grade and crossfall shall be in accordance with the Design and Construction Manual.  
 4) Sidewalk Grade: minimum of 0.5% and maximum of 5%; Sidewalk Crossfall: minimum of 2% and maximum of 4%.  
 5) Water service curb stops shall be on the property line. Installation on hard surfaced area, such as driveways and walkways shall be avoided.  
 6) Refer to Standard Detail Drawing UT-105 for Joint Use Utility Trench.  
 7) A minimum clearance of 0.3 m must be maintained between the gas line and the property line.  
 8) If utilities cannot be installed according to this standard, they are to be installed as close as possible to the prescribed location subject to the approval of the City.  
 9) Spacing between streetlights and trees should be sufficient to ensure no interference between tree canopy and lighting fixture.

CITY OF BRANTFORD	
DETAILED SECTION LOCAL STREET (18.5m ROW 7.8m ROAD WIDTH)	
DATE: FEB. 2020 REV: JAN. 2022 DRAWN BY: E.K.	H-101

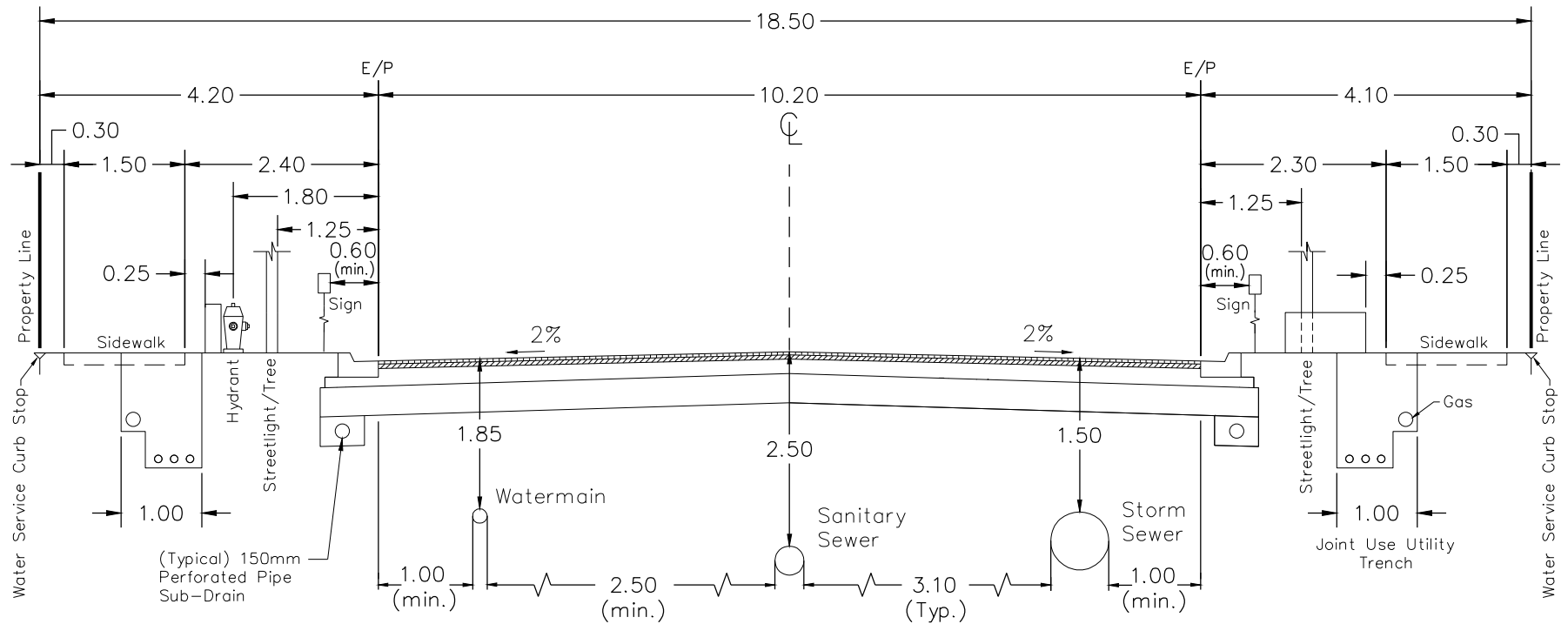

**DETAILED SECTION – LOCAL STREET**

N.T.S.

- NOTE: 1) All dimensions are in metres unless otherwise shown.  
 2) Curb and gutter to meet O.P.S.D. or City of Brantford detail drawing RD-104 for two-stage curb construction in accordance with project drawings  
 3) Road grade and crossfall shall be in accordance with the Design and Construction Manual.  
 4) Sidewalk Grade: minimum of 0.5% and maximum of 5%; Sidewalk Crossfall: minimum of 2% and maximum of 4%.  
 5) Water service curb stops shall be on the property line. Installation on hard surfaced area, such as driveways and walkways shall be avoided.  
 6) Refer to Standard Detail Drawing UT-105 for Joint Use Utility Trench.  
 7) A minimum clearance of 0.3 m must be maintained between the gas line and the property line.  
 8) If utilities cannot be installed according to this standard, they are to be installed as close as possible to the prescribed location subject to the approval of the City.  
 9) Spacing between streetlights and trees should be sufficient to ensure no interference between tree canopy and lighting fixture.

<b>CITY OF BRANTFORD</b>	
<b>DETAILED SECTION LOCAL STREET (18.5m ROW 10.2m ROAD WIDTH)</b>	
DATE: FEB. 2020 REV: JAN. 2022 DRAWN BY: E.K.	<b>H-102</b>

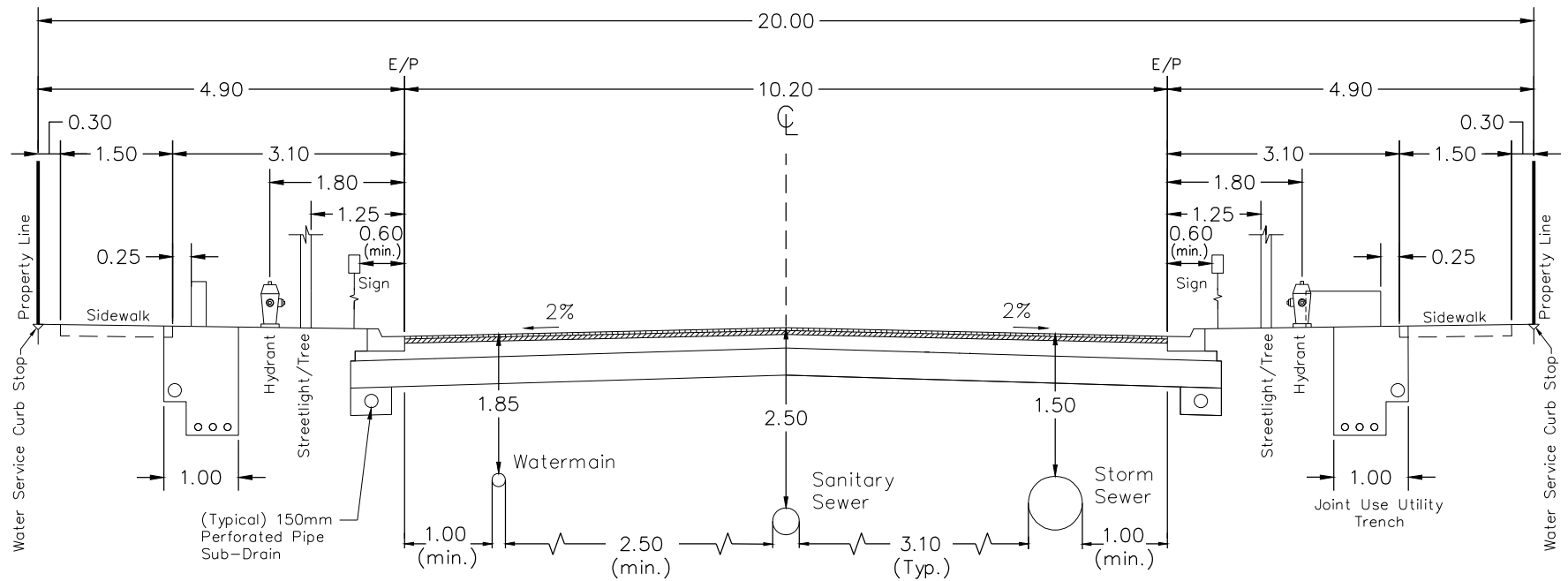

**DETAILED SECTION – LOCAL STREET**

N.T.S.

- NOTE: 1) All dimensions are in metres unless otherwise shown.  
 2) Curb and gutter to meet O.P.S.D. or City of Brantford detail drawing RD-104 for two-stage curb construction in accordance with project drawings  
 3) Road grade and crossfall shall be in accordance with the Design and Construction Manual.  
 4) Sidewalk Grade: minimum of 0.5% and maximum of 5%; Sidewalk Crossfall: minimum of 2% and maximum of 4%.  
 5) Water service curb stops shall be on the property line. Installation on hard surfaced area, such as driveways and walkways shall be avoided.  
 6) Refer to Standard Detail Drawing UT-105 for Joint Use Utility Trench.  
 7) A minimum clearance of 0.3 m must be maintained between the gas line and the property line.  
 8) If utilities cannot be installed according to this standard, they are to be installed as close as possible to the prescribed location subject to the approval of the City.  
 9) Spacing between streetlights and trees should be sufficient to ensure no interference between tree canopy and lighting fixture.

CITY OF BRANTFORD

DETAILED SECTION  
 LOCAL STREET  
 (20.0m ROW 10.2m ROAD WIDTH)

DATE: FEB. 2020  
 REV: JAN. 2022  
 DRAWN BY: E.K.

H-102B



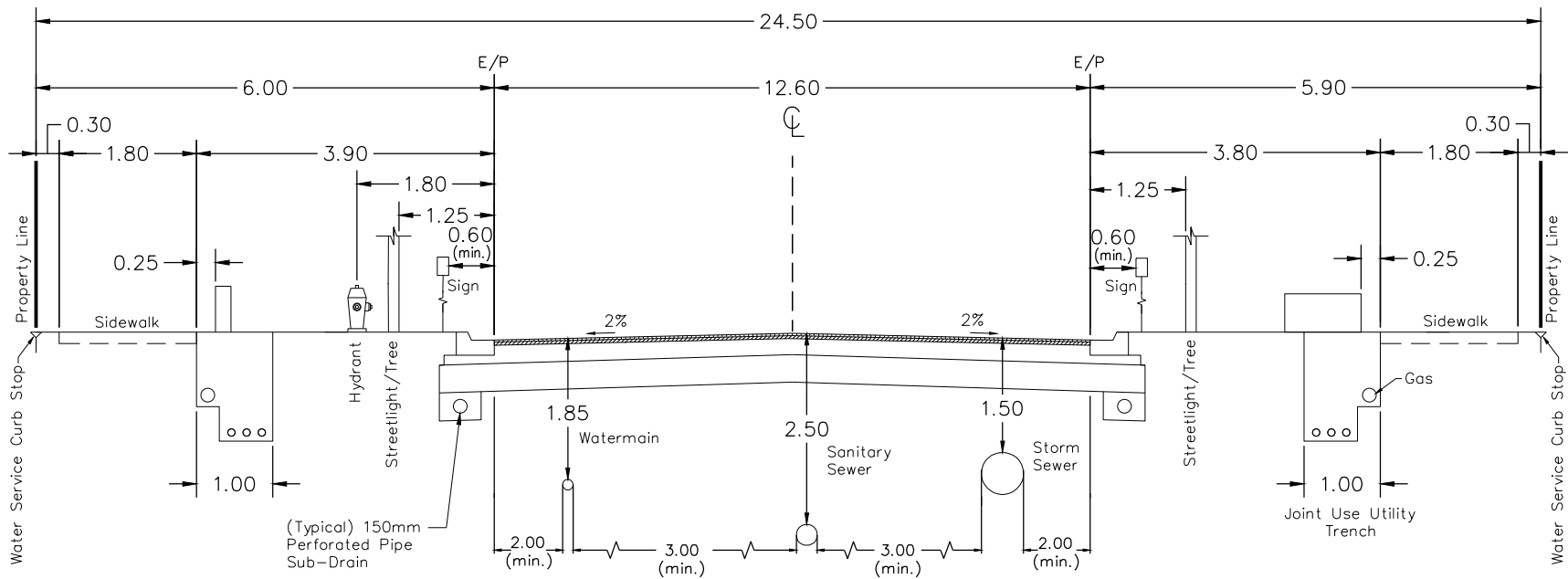

**DETAILED SECTION – MINOR COLLECTOR**

N.T.S.

- NOTE: 1) All dimensions are in metres unless otherwise shown.  
 2) Curb and gutter to meet O.P.S.D. or City of Brantford detail drawing RD-104 for two-stage curb construction in accordance with project drawings  
 3) Road grade and crossfall shall be in accordance with the Design and Construction Manual.  
 4) Sidewalk Grade: minimum of 0.5% and maximum of 5%; Sidewalk Crossfall: minimum of 2% and maximum of 4%.  
 5) Water service curb stops shall be on the property line. Installation on hard surfaced area, such as driveways and walkways shall be avoided.  
 6) Refer to Standard Detail Drawing UT-105 for Joint Use Utility Trench.  
 7) A minimum clearance of 0.3 m must be maintained between the gas line and the property line.  
 8) If utilities cannot be installed according to this standard, they are to be installed as close as possible to the prescribed location subject to the approval of the City.  
 9) Spacing between streetlights and trees should be sufficient to ensure no interference between tree canopy and lighting fixture.

CITY OF BRANTFORD	
DETAILED SECTION MINOR COLLECTOR (24.5m ROW 12.6m ROAD WIDTH)	
DATE: FEB. 2020 REV: JAN. 2022 DRAWN BY: E.K.	H-103

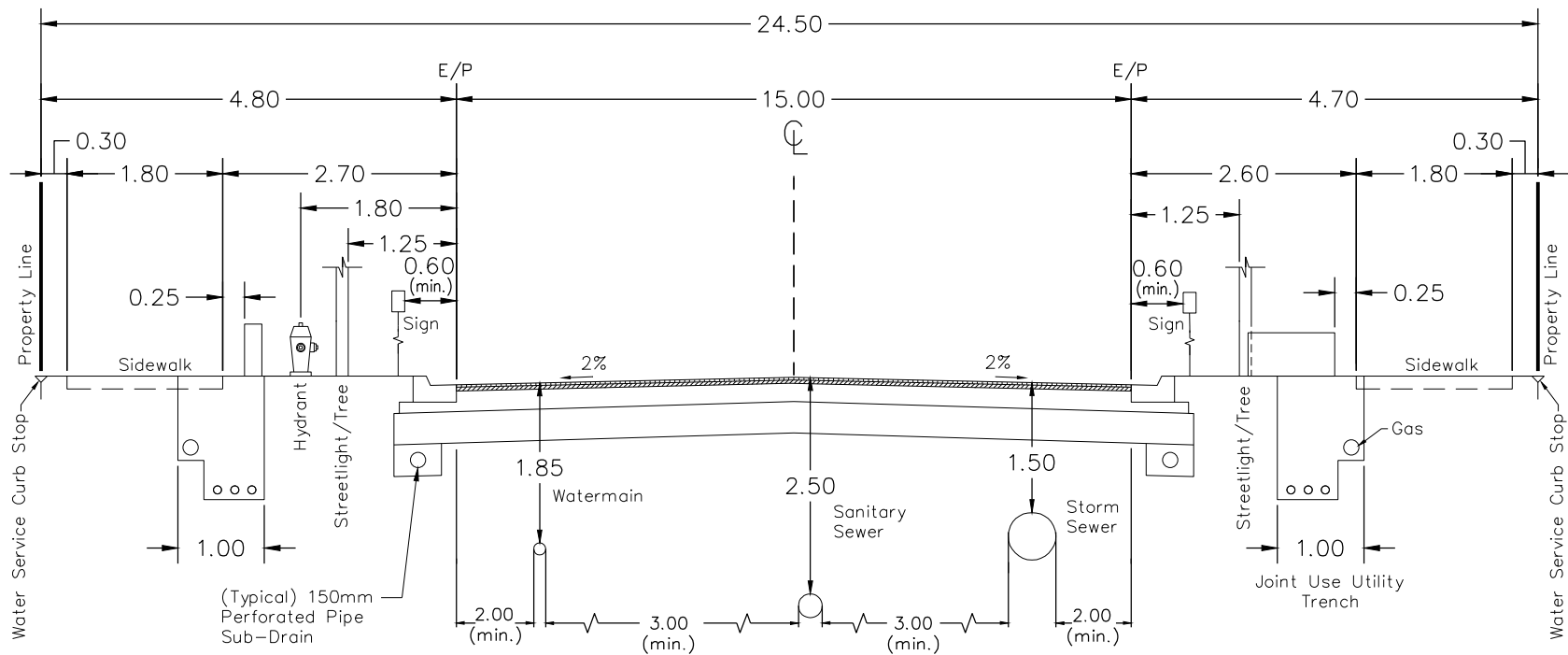

**DETAILED SECTION – MINOR COLLECTOR**

N.T.S.

- NOTE: 1) All dimensions are in metres unless otherwise shown.  
 2) Curb and gutter to meet O.P.S.D. or City of Brantford detail drawing RD-104 for two-stage curb construction in accordance with project drawings  
 3) Road grade and crossfall shall be in accordance with the Design and Construction Manual.  
 4) Sidewalk Grade: minimum of 0.5% and maximum of 5%; Sidewalk Crossfall: minimum of 2% and maximum of 4%.  
 5) Water service curb stops shall be on the property line. Installation on hard surfaced area, such as driveways and walkways shall be avoided.  
 6) Refer to Standard Detail Drawing UT-105 for Joint Use Utility Trench.  
 7) A minimum clearance of 0.3 m must be maintained between the gas line and the property line.  
 8) If utilities cannot be installed according to this standard, they are to be installed as close as possible to the prescribed location subject to the approval of the City.  
 9) Spacing between streetlights and trees should be sufficient to ensure no interference between tree canopy and lighting fixture.

CITY OF BRANTFORD

DETAILED SECTION  
 MINOR COLLECTOR  
 (24.5m ROW 15.0m ROAD WIDTH)

DATE: FEB. 2020  
 REV: JAN. 2022  
 DRAWN BY: E.K.

H-104

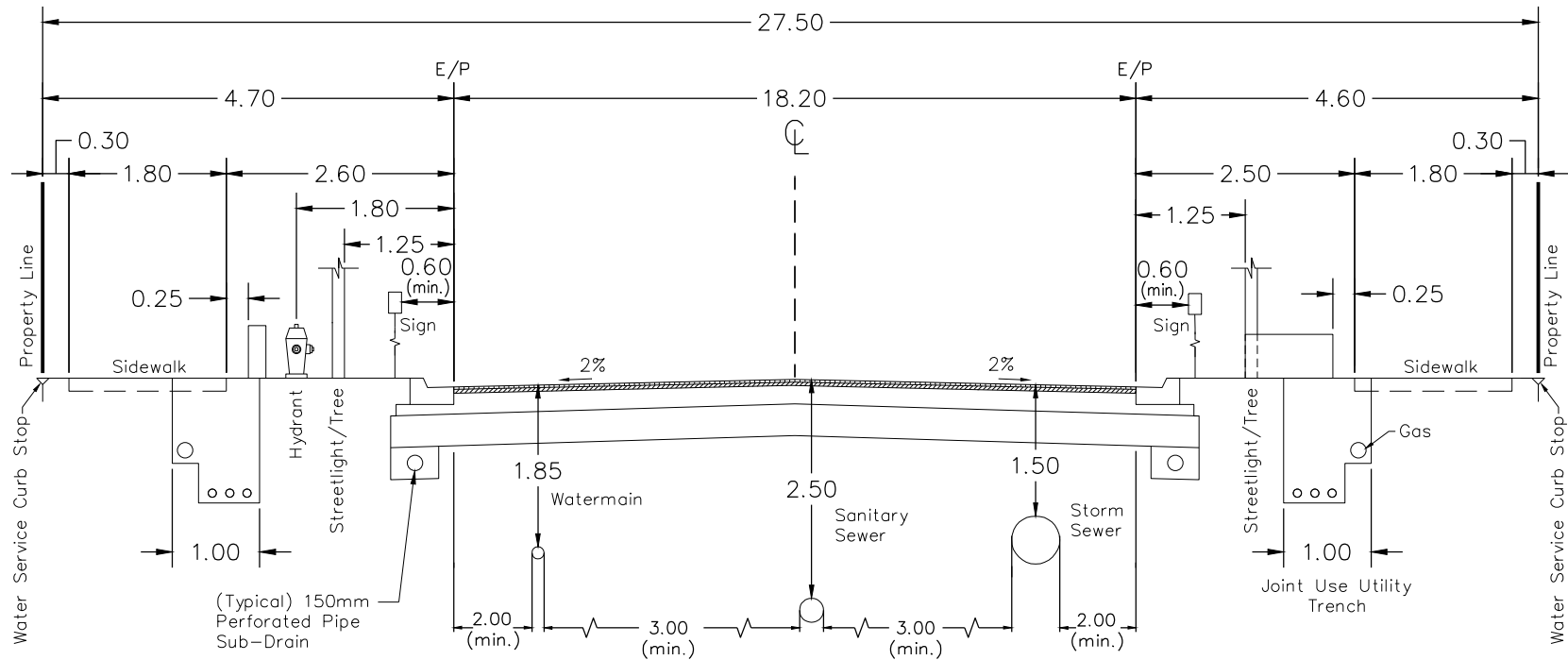

**DETAILED SECTION – MAJOR COLLECTOR**

N.T.S.

- NOTE: 1) All dimensions are in metres unless otherwise shown.  
 2) Curb and gutter to meet O.P.S.D. or City of Brantford detail drawing RD-104 for two-stage curb construction in accordance with project drawings  
 3) Road grade and crossfall shall be in accordance with the Design and Construction Manual.  
 4) Sidewalk Grade: minimum of 0.5% and maximum of 5%; Sidewalk Crossfall: minimum of 2% and maximum of 4%.  
 5) Water service curb stops shall be on the property line. Installation on hard surfaced area, such as driveways and walkways shall be avoided.  
 6) Refer to Standard Detail Drawing UT-105 for Joint Use Utility Trench.  
 7) A minimum clearance of 0.3 m must be maintained between the gas line and the property line.  
 8) If utilities cannot be installed according to this standard, they are to be installed as close as possible to the prescribed location subject to the approval of the City.  
 9) Spacing between streetlights and trees should be sufficient to ensure no interference between tree canopy and lighting fixture.

CITY OF BRANTFORD

DETAILED SECTION  
 MAJOR COLLECTOR  
 (27.5m ROW 18.2m ROAD WIDTH)

DATE: FEB. 2020  
 REV: JAN. 2022  
 DRAWN BY: E.K.

H-105

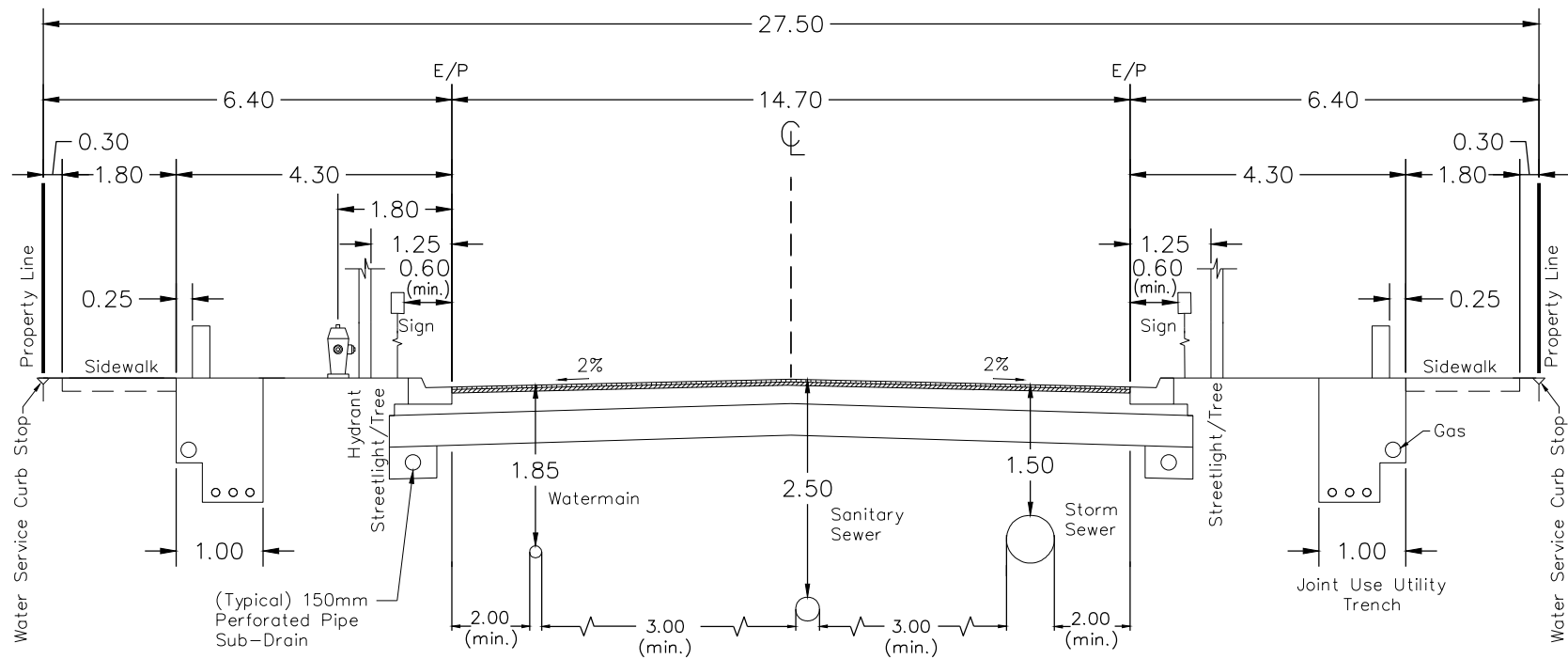

**DETAILED SECTION – MAJOR COLLECTOR**  
N.T.S.

- NOTE: 1) All dimensions are in metres unless otherwise shown.  
 2) Curb and gutter to meet O.P.S.D. or City of Brantford detail drawing RD-104 for two-stage curb construction in accordance with project drawings  
 3) Road grade and crossfall shall be in accordance with the Design and Construction Manual.  
 4) Sidewalk Grade: minimum of 0.5% and maximum of 5%; Sidewalk Crossfall: minimum of 2% and maximum of 4%.  
 5) Water service curb stops shall be on the property line. Installation on hard surfaced area, such as driveways and walkways shall be avoided.  
 6) Refer to Standard Detail Drawing UT-105 for Joint Use Utility Trench.  
 7) A minimum clearance of 0.3 m must be maintained between the gas line and the property line.  
 8) If utilities cannot be installed according to this standard, they are to be installed as close as possible to the prescribed location subject to the approval of the City.  
 9) Spacing between streetlights and trees should be sufficient to ensure no interference between tree canopy and lighting fixture.

CITY OF BRANTFORD

DETAILED SECTION  
 MAJOR COLLECTOR  
 (27.5m ROW 14.7m ROAD WIDTH)

DATE: FEB. 2023  
 REV:  
 DRAWN BY: E.K.

H-105B

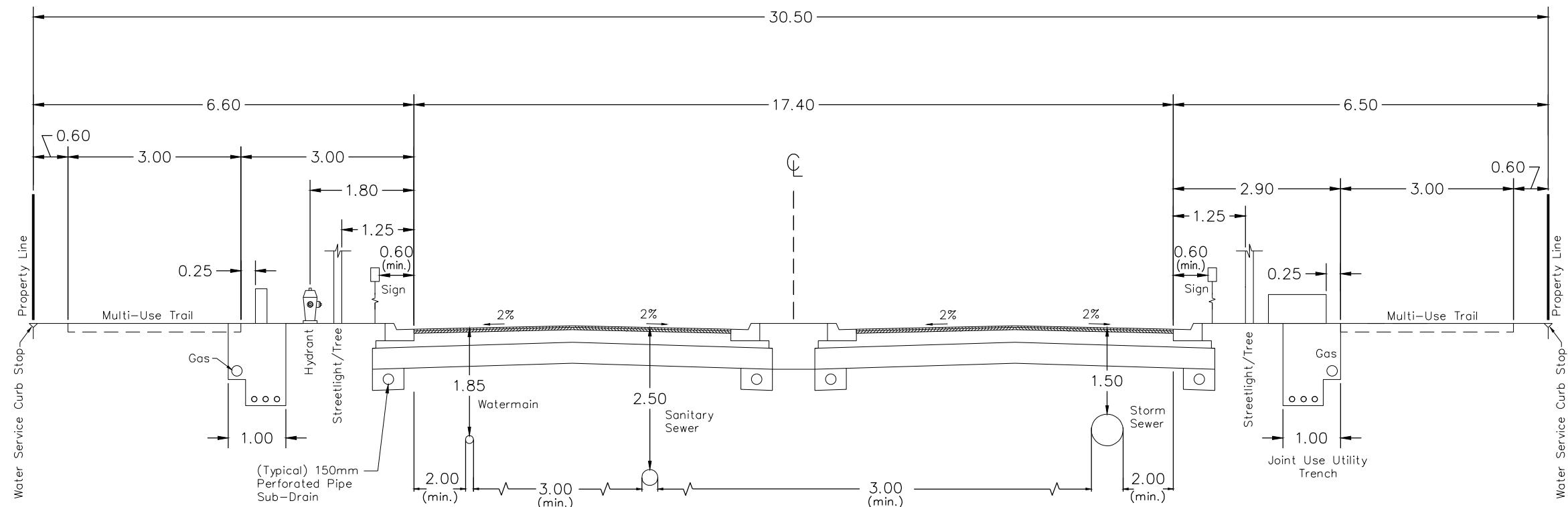

**DETAILED SECTION – MAJOR COLLECTOR**  
N.T.S.

- NOTE: 1) All dimensions are in metres unless otherwise shown.  
 2) Curb and gutter to meet O.P.S.D. or City of Brantford detail drawing RD-104 for two-stage curb construction in accordance with project drawings  
 3) Road grade and crossfall shall be in accordance with the Design and Construction Manual.  
 4) Sidewalk Grade: minimum of 0.5% and maximum of 5%; Sidewalk Crossfall: minimum of 2% and maximum of 4%.  
 5) Water service curb stops shall be on the property line. Installation on hard surfaced area, such as driveways and walkways shall be avoided.  
 6) Refer to Standard Detail Drawing UT-105 for Joint Use Utility Trench.  
 7) A minimum clearance of 0.3 m must be maintained between the gas line and the property line.  
 8) If utilities cannot be installed according to this standard, they are to be installed as close as possible to the prescribed location subject to the approval of the City.  
 9) Spacing between streetlights and trees should be sufficient to ensure no interference between tree canopy and lighting fixture.

CITY OF BRANTFORD	
DETAILED SECTION MAJOR COLLECTOR (30.5m ROW 17.4m ROAD WIDTH)	
DATE: FEB. 2020 REV: JAN. 2022 DRAWN BY: E.K.	H-106

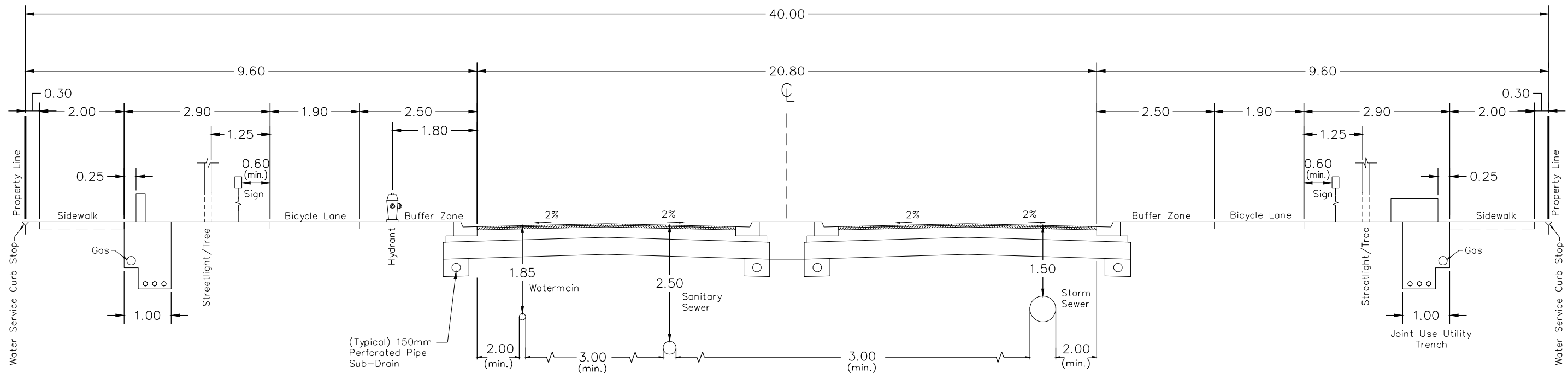

**DETAILED SECTION – ARTERIAL**

N.T.S.

- NOTE: 1) All dimensions are in metres unless otherwise shown.  
 2) Curb and gutter to meet O.P.S.D. or City of Brantford detail drawing RD-104 for two-stage curb construction in accordance with project drawings  
 3) Road grade and crossfall shall be in accordance with the Design and Construction Manual.  
 4) Sidewalk Grade: minimum of 0.5% and maximum of 5%; Sidewalk Crossfall: minimum of 2% and maximum of 4%.  
 5) Water service curb stops shall be on the property line. Installation on hard surfaced area, such as driveways and walkways shall be avoided.  
 6) Refer to Standard Detail Drawing UT-105 for Joint Use Utility Trench.  
 7) A minimum clearance of 0.3 m must be maintained between the gas line and the property line.  
 8) If utilities cannot be installed according to this standard, they are to be installed as close as possible to the prescribed location subject to the approval of the City.  
 9) Spacing between streetlights and trees should be sufficient to ensure no interference between tree canopy and lighting fixture.  
 10) Preferred sidewalk width = 2.0 m, minimum width = 1.8 m for arterial road.

CITY OF BRANTFORD

DETAILED SECTION  
 ARTERIAL  
 (40.0m ROW 20.8m ROAD WIDTH)

DATE: FEB. 2020  
 REV: FEB. 2023  
 DRAWN BY: E.K.

H-107

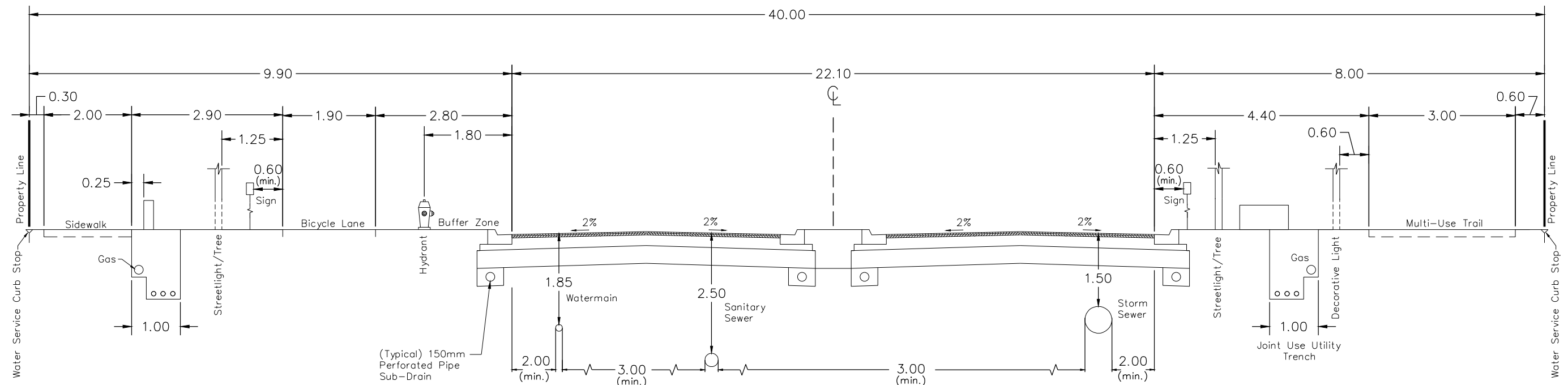

**DETAILED SECTION – ARTERIAL**

N.T.S.

- NOTE: 1) All dimensions are in metres unless otherwise shown.  
 2) Curb and gutter to meet O.P.S.D. or City of Brantford detail drawing RD-104 for two-stage curb construction in accordance with project drawings  
 3) Road grade and crossfall shall be in accordance with the Design and Construction Manual.  
 4) Sidewalk Grade: minimum of 0.5% and maximum of 5%; Sidewalk Crossfall: minimum of 2% and maximum of 4%.  
 5) Water service curb stops shall be on the property line. Installation on hard surfaced area, such as driveways and walkways shall be avoided.  
 6) Refer to Standard Detail Drawing UT-105 for Joint Use Utility Trench.  
 7) A minimum clearance of 0.3 m must be maintained between the gas line and the property line.  
 8) If utilities cannot be installed according to this standard, they are to be installed as close as possible to the prescribed location subject to the approval of the City.  
 9) Spacing between streetlights and trees should be sufficient to ensure no interference between tree canopy and lighting fixture.  
 10) Preferred sidewalk width = 2.0 m, minimum width = 1.8 m for arterial road.

CITY OF BRANTFORD

DETAILED SECTION  
 ARTERIAL  
 (40.0m ROW 22.1m ROAD WIDTH)

DATE: FEB. 2020  
 REV: FEB. 2023  
 DRAWN BY: E.K.

H-108

**DETAILED SECTION N.T.S.**  
**MINOR COLLECTOR (INDUSTRIAL ROAD)**  
 27.5m R.O.W. - 10.0m ROAD WIDTH

- NOTE: 1) All dimensions are in metres unless otherwise shown.  
 2) Curb and gutter to meet O.P.S.D. or City of Brantford detail drawing RD-104 for two-stage curb construction in accordance with project drawings  
 3) Road grade and crossfall shall be in accordance with the Design and Construction Manual.  
 4) Sidewalk Grade: minimum of 0.5% and maximum of 5%; Sidewalk Crossfall: minimum of 2% and maximum of 4%.  
 5) Water service curb stops shall be on the property line. Installation on hard surfaced area, such as driveways and walkways shall be avoided.  
 6) Refer to Standard Detail Drawing UT-105 for Joint Use Utility Trench.  
 7) A minimum clearance of 0.3 m must be maintained between the gas line and the property line.  
 8) If utilities cannot be installed according to this standard, they are to be installed as close as possible to the prescribed location subject to the approval of the City.  
 9) Spacing between streetlights and trees should be sufficient to ensure no interference between tree canopy and lighting fixture.

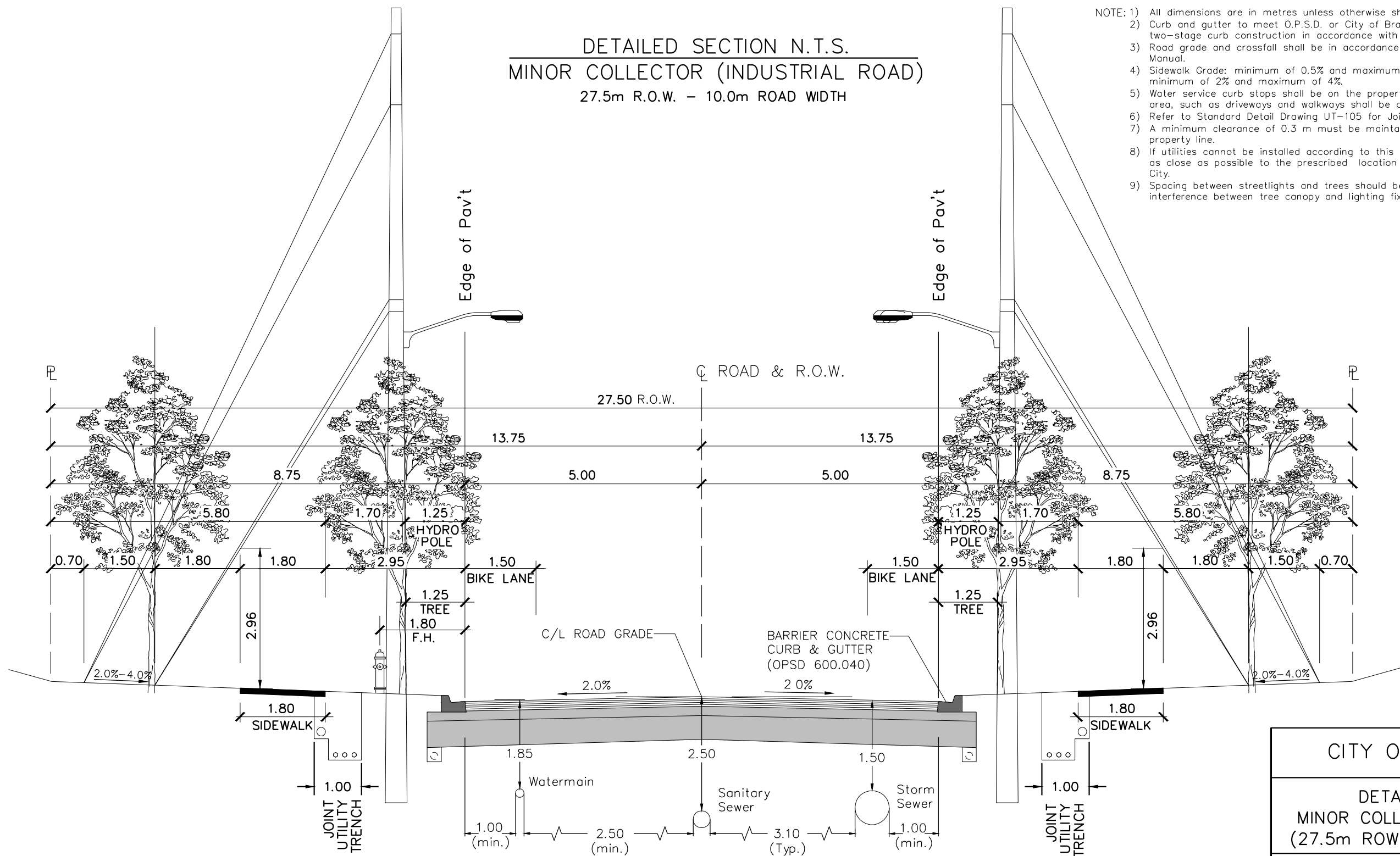

<b>CITY OF BRANTFORD</b>	
<b>DETAILED SECTION MINOR COLLECTOR (INDUSTRIAL) (27.5m ROW 10.0m ROAD WIDTH)</b>	
DATE: JAN. 2021 REV:	<b>H-109</b>



WATERMAINS

# Standard Drawings

### STANDARD DRAWINGS AND DETAILS

Drawing No.	Title
W-100	Typical 19mm and 25mm Water Service and 15mm and 25mm Water Meter Installation
W-100A	Typical 25mm Non-Metallic Water Service and 15mm to 25mm Water Meter Installation
W-100B	Typical 38mm and 50mm Copper or Non-Metallic Water Service
W-101	Standard 38mm Water Meter Installation
W-102	Standard 50mm Water Meter Installation
W-103	Standard 75mm Turbine Meter Installation
W-104	Standard 100mm Turbine Meter Installation
W-105	Standard 150mm Turbine Meter Installation
W-106	Standard 200mm Turbine Meter Installation
W-107	Transmitter and Scan Disc Installation
W-108	Ground Wire Connections for New Services
W-109	Ground Wire Connections for New Services
W-110	Typical Meter Chamber
W-111	Typical Water Service Installation Through Unexcavated Area Passed Footings
W-112	Backflow Prevention on External Irrigation Systems
W-113A	Temporary Connection of New Watermains or Services (100mm or Larger) to the Existing Water System
W-113B	Final Connection of New Watermains or Services (100mm or Larger) to the Existing Water System
W-114	Standard Compound Meter Installation
W-115	Typical New Water Service Installation Through Excavated Area Passed Footings
W-116	Typical Multiple Meter Installation c/w Header Main
W-201	Standard Water Connection Details for 19 mm (3/4") and 25 mm (1") Services and Service Bedding for Corrosive Soil
W-202	Piping Arrangement for 38mm and 50mm Water Services
W-203	Watermain Servicing Lowering Detail
W-301	Legend
W-303	Valve and Valve Box Installation for 100mm to 350mm Watermain
W-304	Watermain Location Detail
W-305	Standard 19mm (3/4") or 25mm (1") Blow-Off

Drawing No.	Title
W-306	Standard 50mm (2") Copper Blow-Off Installation
W-307	Anode Installation
W-308A	Test Box and Tracer Wire Installation in Conjunction with a Steel Liner
W-308B	CDR 250mm x 380mm Series Box and Cover Test Point
W-308C	Box and Cover Test Point Underground Closure
W-309	Typical Horizontal Thrust Restraint
W-310	Typical Vertical Thrust Restraint
W-311	Typical Installation of Valve Box on Newly Reconstructed Streets
W-312	Insulation of Sewers and Watermains in Shallow Trenches "Frost Barrier"
W-312A	Insulation of Sewers and Watermains in Shallow Trenches "Frost Box"
W-312B	Insulation of Sewers, Watermains and Service Connections Adjacent to Ventilated Structures
W-313	Backfill Requirements for Utility Crossings Underneath Existing Watermains
W--314	Watermain Encasement Over Box Culvert
W-315	Typical Swing Check Valve Chamber
W-316	Combination Air Release/Air Vacuum Valve Chamber
W-317	Bacteriological Sampling Points
W-318	Standard 38mm Copper Blow-Off Installation
W-319	Pressure Reducing Valve Chamber
W-320	Automatic Flushing Device
W-402	Private Drain Lowering Detail
W-403	Valve Chamber For 500mm Side Operated Gate Valve
W-404	Pipe and Valve Support
W-405	Valve Support
W-406	Pipe Support
W-407	Lifting Hook
W-408	Lifting Hook Detail for Chambers
W-409	Standard Manhole Steps - Aluminum
W-410	Blow-Off Connection at Access Chamber

Drawing No.	Title
W-411	Removable Slab Lifting Hole Details
W-412	Chamber Valve Box
W-413	1067mm Heavy Duty Manhole Cover & Frame
W-501	Hydrant Installation
W-502	Hydrant Detail with Flanged Tee and Flanged Gate Valve
W-503	Hydrant Installation
W-504	Hydrant Installation c/w Anchor Tee and Valve
W-504A	Hydrant Installation c/w Anchor Tee, Valve and Test Point for P.V.C. Watermain
W-504B	Hydrant Installation c/w Anchor Tee, Valve and Test Point for P.V.C. Watermain
W-505	Hydrant Detail with Tapping Valve and Sleeve
W-506	Typical Installation Depth
W-506A	Typical Riser Installation on McAvity Hydrant
W-506B	Typical Extension Installation for Century, B-50-B-18 and B-50-B-24 Hydrant
W-506C	Typical Extension Installation for Modern Centurion Hydrant
W-506D	Typical Extension Installation Darling S-300 Hydrant
W-601	Typical Water Service Location (Single Family Lot) Subdivision
W-602	Typical Water Service Location (Semi-Detached Lot) Subdivisions
W-603A	Standard As Built Measurement for Watermain Construction
W-603B	Standard As Built Measurement for Watermain Construction
W-604	Standard Watermain Construction for New Cul-De-Sac
W-605	Typical Water Meter Location
A-101	Shoulder Paving

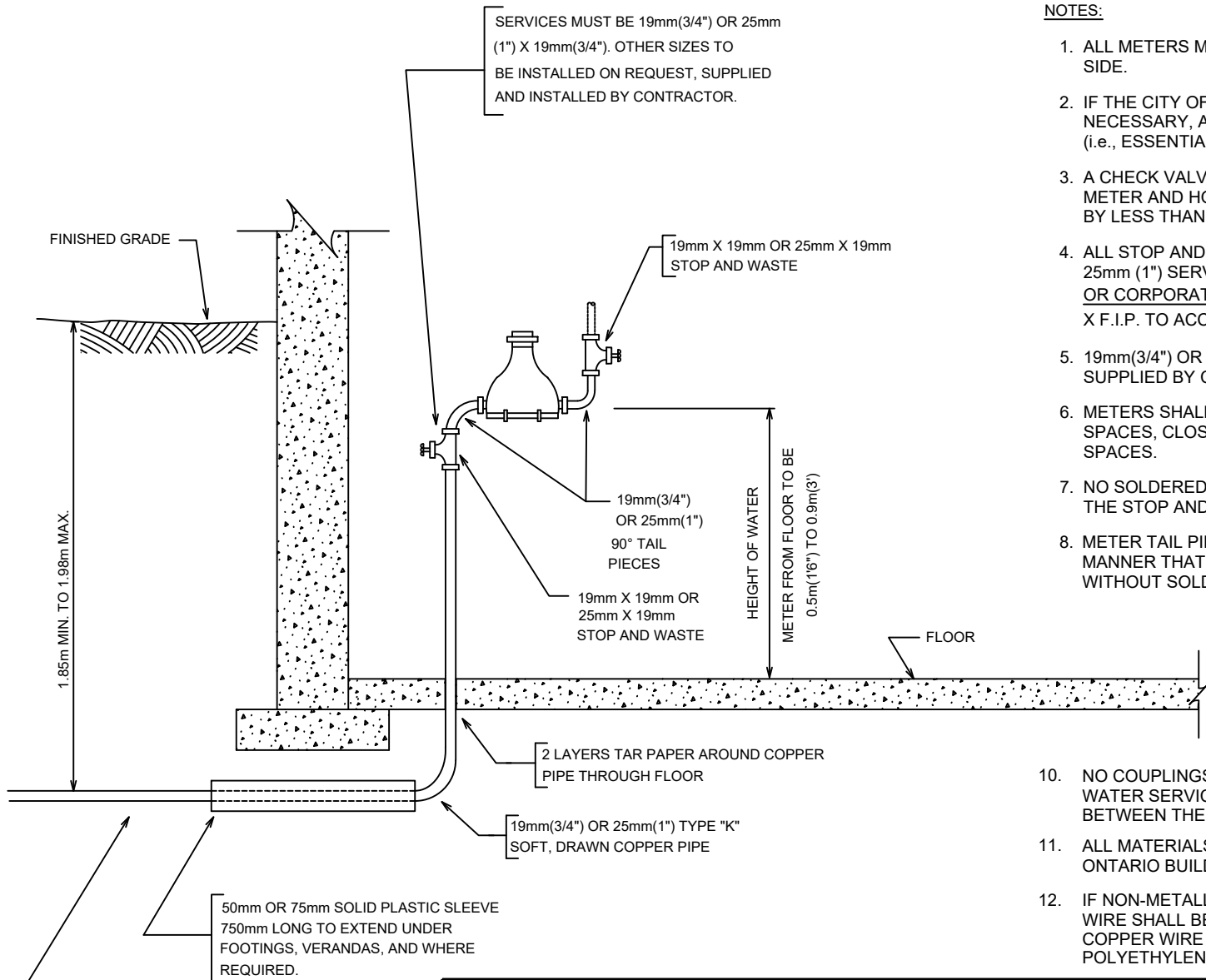

**NOTES:**

1. ALL METERS MUST HAVE A VALVE ON EACH SIDE.
2. IF THE CITY OF BRANTFORD CONSIDERS IT NECESSARY, A BY-PASS SHALL BE INSTALLED (i.e., ESSENTIAL BUSINESS etc., RE: SHUTDOWN).
3. A CHECK VALVE MUST BE INSTALLED IF THE METER AND HOT WATER TANK ARE SEPARATED BY LESS THAN 1.83m (6') OF PIPE.
4. ALL STOP AND WASTES USED ON 19mm (3/4") OR 25mm (1") SERVICES MUST BE FLARED(NO SOLDER) OR CORPORATION STYLE COMPRESSION X F.I.P. TO ACCOMMODATE THE METER TAIL PIECE.
5. 19mm(3/4") OR 25mm(1") 90° TAIL PIECES SUPPLIED BY CITY OF BRANTFORD.
6. METERS SHALL NOT BE INSTALLED IN CRAWL SPACES, CLOSETS OR ANY OTHER CONFINED SPACES.
7. NO SOLDERED JOINTS WILL BE ALLOWED BELOW THE STOP AND WASTE.
8. METER TAIL PIECES MUST BE INSTALLED IN A MANNER THAT ALLOWS EASY REPLACEMENT WITHOUT SOLDERING.
9. IMMEDIATELY AFTER THE WATER SERVICE PASSES UNDER THE FOOTING, IT HAS TO BE BROUGHT UP THROUGH THE FLOOR AND BE METERED AT THAT POINT.
10. NO COUPLINGS WILL BE ALLOWED ON THE COPPER WATER SERVICE UNDER THE FOOTING OR FLOOR OR BETWEEN THE OUTSIDE WALL AND THE METER.
11. ALL MATERIALS MUST CONFORM TO THE CURRENT ONTARIO BUILDING CODE, PART 7.
12. IF NON-METALLIC WATER SERVICE MATERIAL IS USED, TRACER WIRE SHALL BE TWU, NUMBER 8 GAUGE, STRANDED, INSULATED COPPER WIRE WITH 60 MIL. OF WHITE, CROSS-LINKED POLYETHYLENE (PEX) INSULATION.



**TYPICAL 19mm & 25mm WATER SERVICE AND 15mm & 25mm WATER METER INSTALLATION**

ENGINEERING SERVICES DEPARTMENT

DATE: MAR. 1986

REV: NOV. 2021

**W-100**

DRAWN BY:  
A. SCHOEN

NOTES:

1. ALL METERS MUST HAVE A VALVE ON EACH SIDE.
2. IF THE CITY OF BRANTFORD CONSIDERS IT NECESSARY, A BY-PASS SHALL BE INSTALLED (i.e., ESSENTIAL BUSINESS etc., RE: SHUT-DOWN).
3. A CHECK VALVE MUST BE INSTALLED IF THE METER AND HOT WATER TANK ARE SEPARATED BY LESS THAN 1.83m (6') OF PIPE OR PE PIPE (SERIES 160) IS USED FOR SERVICING TO BUILDING.
4. ALL STOP AND WASTES USED ON 25mm (1") SERVICES MUST BE COMPRESSION JOINT CSA APPROVED FOR NON-METALLIC PIPE.
5. 19mm(3/4") OR 25mm(1") 90° TAIL PIECES SUPPLIED BY CITY OF BRANTFORD.
6. METERS SHALL NOT BE INSTALLED IN CRAWL SPACES, CLOSETS OR ANY OTHER CONFINED SPACES
7. NO COUPLINGS WILL BE ALLOWED ON THE COPPER WATER SERVICE UNDER THE FOOTING OR FLOOR OR BETWEEN THE OUTSIDE WALL AND THE METER.
8. METER TAIL PIECES MUST BE INSTALLED IN A MANNER THAT ALLOWS EASY REPLACEMENT WITHOUT SOLDERING.
9. IMMEDIATELY AFTER THE WATER SERVICE PASSES UNDER THE FOOTING, IT HAS TO BE BROUGHT UP THROUGH THE FLOOR AND BE METERED AT THAT POINT.
10. IF P.E. PIPE(SERIES 160) OR ANY NON-METALLIC PIPE IS USED. IT MUST BE PROPERLY SECURED TO SUPPORT THE WEIGHT OF THE WATER METER. A CHECK VALVE MUST BE INSTALLED IN THE STOP WASTE VALE IMMEDIATELY AFTER THE P.E. PIPE (SERIES 160) ENDS.
11. A COPY OF E.S.A. CERTIFICATE INDICATING THAT HYDRO IS NOT GROUNDED TO THE WATER SERVICE MUST BE SUBMITTED PRIOR TO THE THE RELEASE OF THE WATER METER.
12. ALL MATERIALS MUST CONFORM TO THE CURRENT ONTARIO BUILDING CODE, PART 7.
13. TRACER WIRE SHALL BE TWU, NUMBER 8 GAUGE, STRANDED, INSULATED COPPER WIRE WITH 60 MIL. OF WHITE, CROSS-LINKED POLYETHYLENE (PEX) INSULATION.

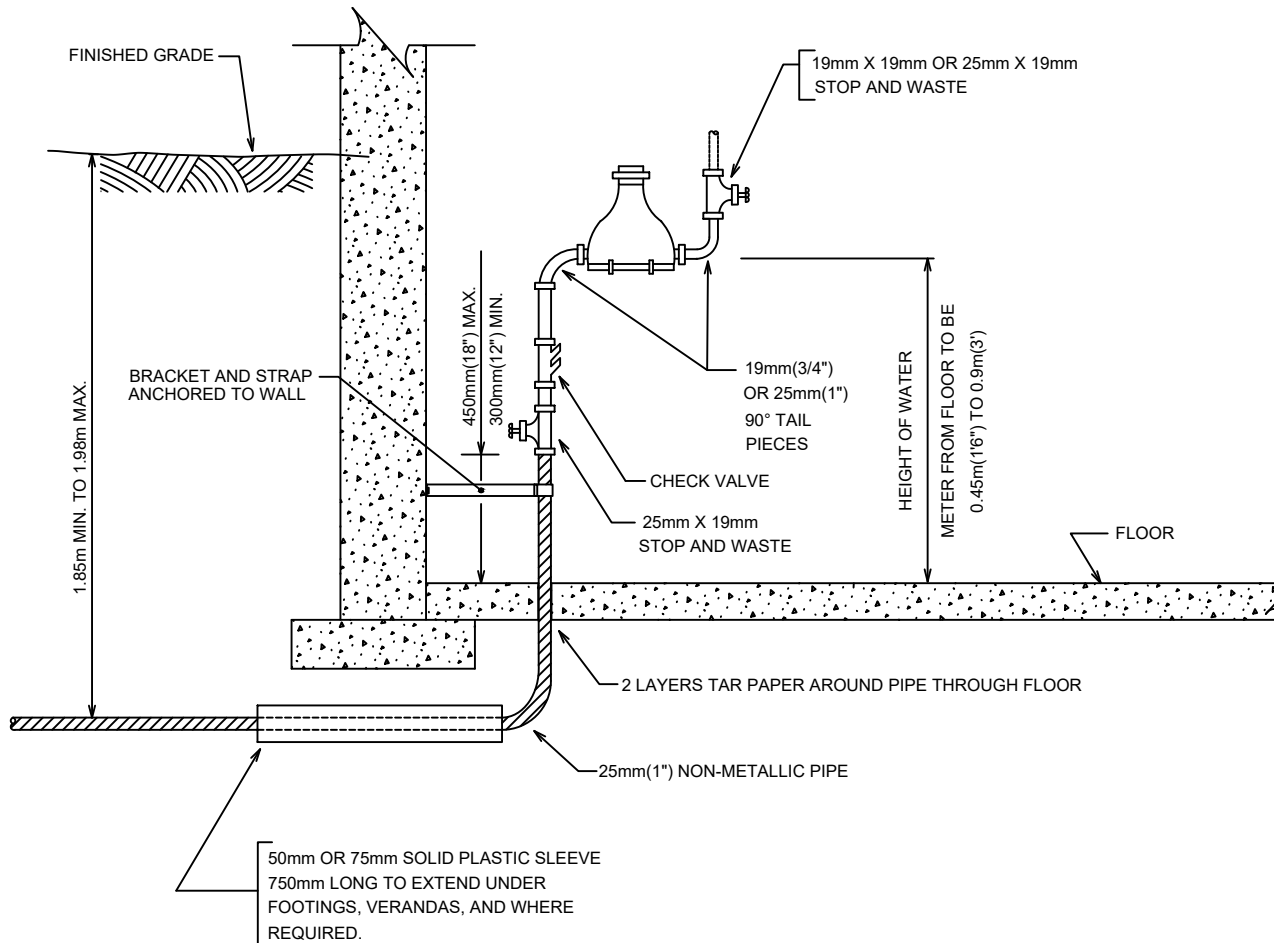

**TYPICAL 25MM NON-METALLIC WATER SERVICE AND 15MM TO 25MM WATER METER INSTALLATION**

N.T.S. ENGINEERING SERVICES DEPARTMENT	
DATE: AUG. 2004	
REV: NOV. 2021	
<b>W-100A</b>	DRAWN BY: J. RATANAVANH

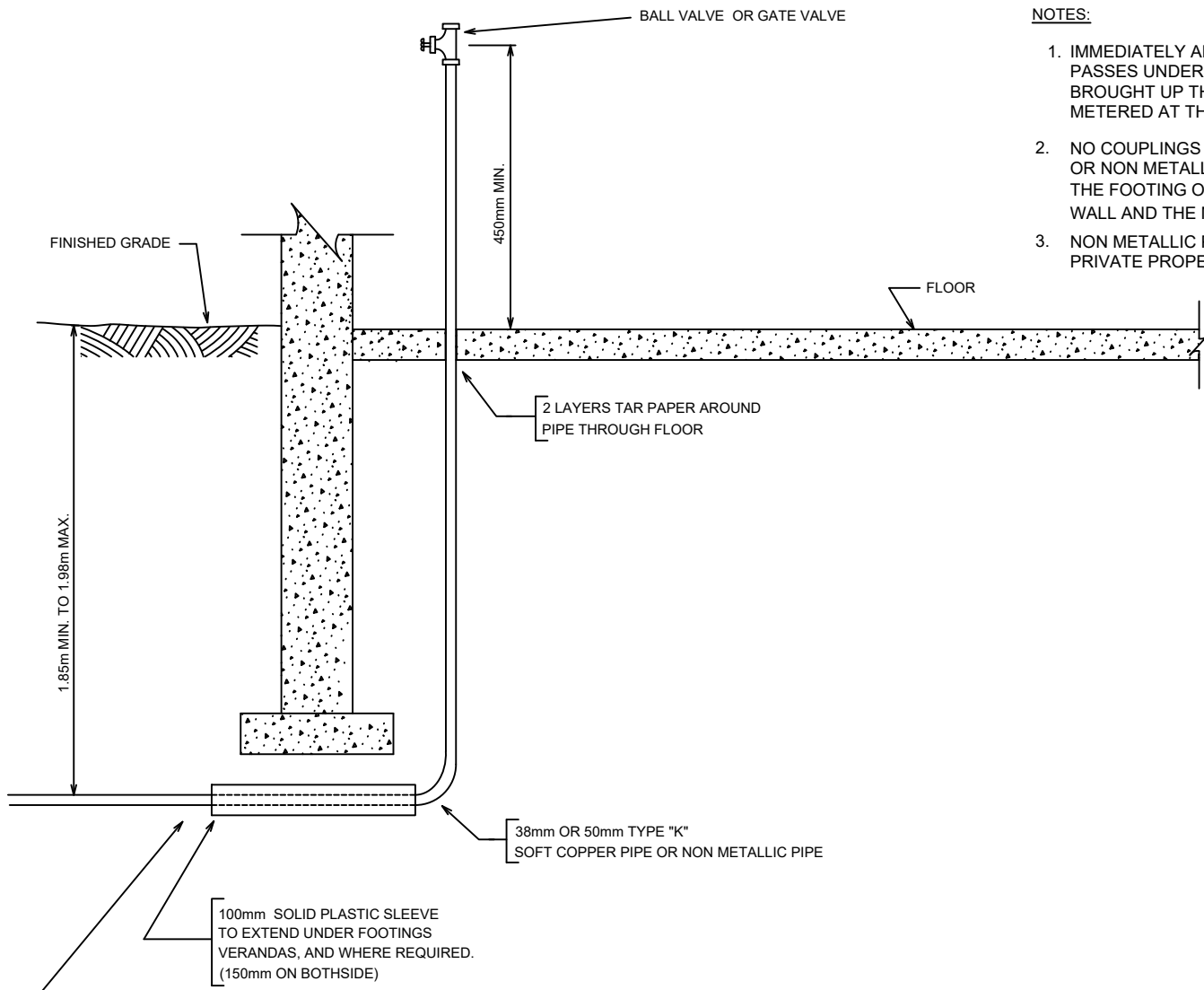

**NOTES:**

1. IMMEDIATELY AFTER THE WATER SERVICE PASSES UNDER THE FOOTING, IT HAS TO BE BROUGHT UP THROUGH THE FLOOR AND BE METERED AT THAT POINT.
2. NO COUPLINGS WILL BE ALLOWED ON THE COPPER OR NON METALLIC WATER SERVICE UNDER THE THE FOOTING OR THE FLOOR BETWEEN THE OUTSIDE WALL AND THE METER.
3. NON METALLIC PIPE WILL ONLY BE ALLOWED ON PRIVATE PROPERTY SIDE.



**TYPICAL 38mm & 50mm  
COPPER OR NON-METALLIC  
WATER SERVICE**

ENGINEERING SERVICES DEPARTMENT	
DATE: DEC. 2006	
REV: NOV. 2021	
<b>W-100B</b>	DRAWN BY: J. RATANAVANH

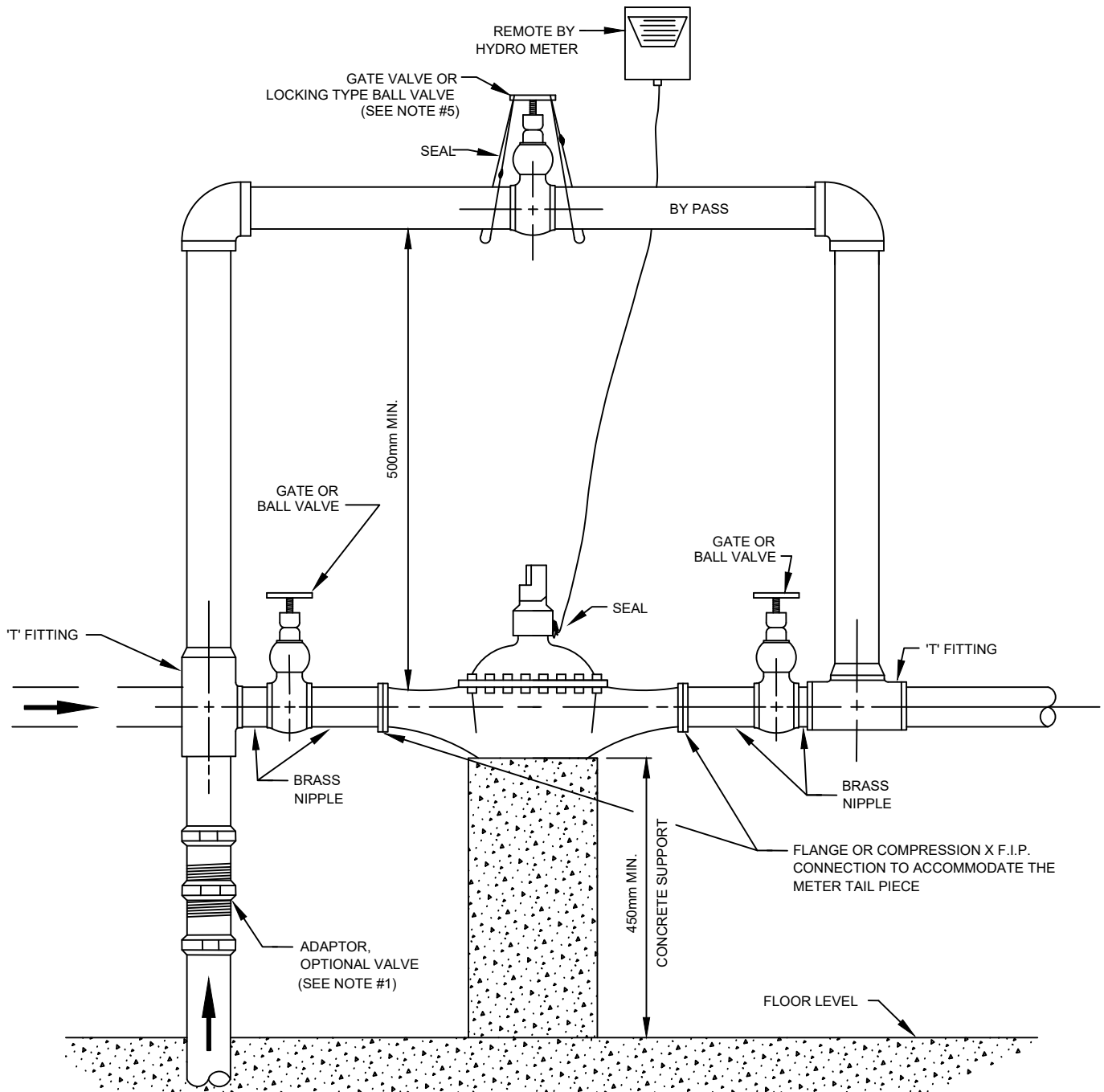

**NOTES:**

1. A BALL OR GATE VALVE MAY BE SUBSTITUTED WHERE THE ADAPTOR IS LOCATED. IF A VALVE IS NOT INSTALLED IN THIS LOCATION, SOLDERING WILL NOT BE ALLOWED BEFORE ANY CONTROLLING VALVE.
2. REMOTE TO BE MOUNTED ON HYDRO STACK OR INSIDE NEXT TO HYDRO METER.
3. ALL VALVES TO OPERATE CLOCKWISE TO CLOSE. NO SOLDERED JOINTS WILL BE ALLOWED BELOW VALVES.
4. BY-PASS CAN BE MOUNTED VERTICALLY OR HORIZONTALLY.
5. ALL MATERIALS AS SHOWN, SHALL BE SUPPLIED AND INSPECTED BY OTHERS.
6. BALL VALVE TO BE LOCKING TYPE IF USED ON BY-PASS.
7. CITY ENGINEERING PERSONNEL SHALL INSPECT INSTALLATION PRIOR TO TURNING ON WATER SUPPLY.
8. METER FLANGES MUST BE INSTALLED IN A MANNER WHICH THEY MAY BE EASILY ACCESSED FOR REPLACEMENT WITHOUT SOLDERING.
9. IMMEDIATELY AFTER THE WATER SERVICE PASSES UNDER THE FOOTING. IT HAS TO BE BROUGHT UP THROUGH THE FLOOR AND BE METERED AT THAT POINT.
10. ALL MATERIALS MUST CONFORM TO THE CURRENT ONTARIO BUILDING CODE, PART 7.



## STANDARD 38mm WATER METER INSTALLATION

ENGINEERING SERVICES DEPARTMENT

DATE: AUG. 1997

REV: NOV. 2021

N.T.S.

W-101

DRAWN BY:  
A. SCHOEN



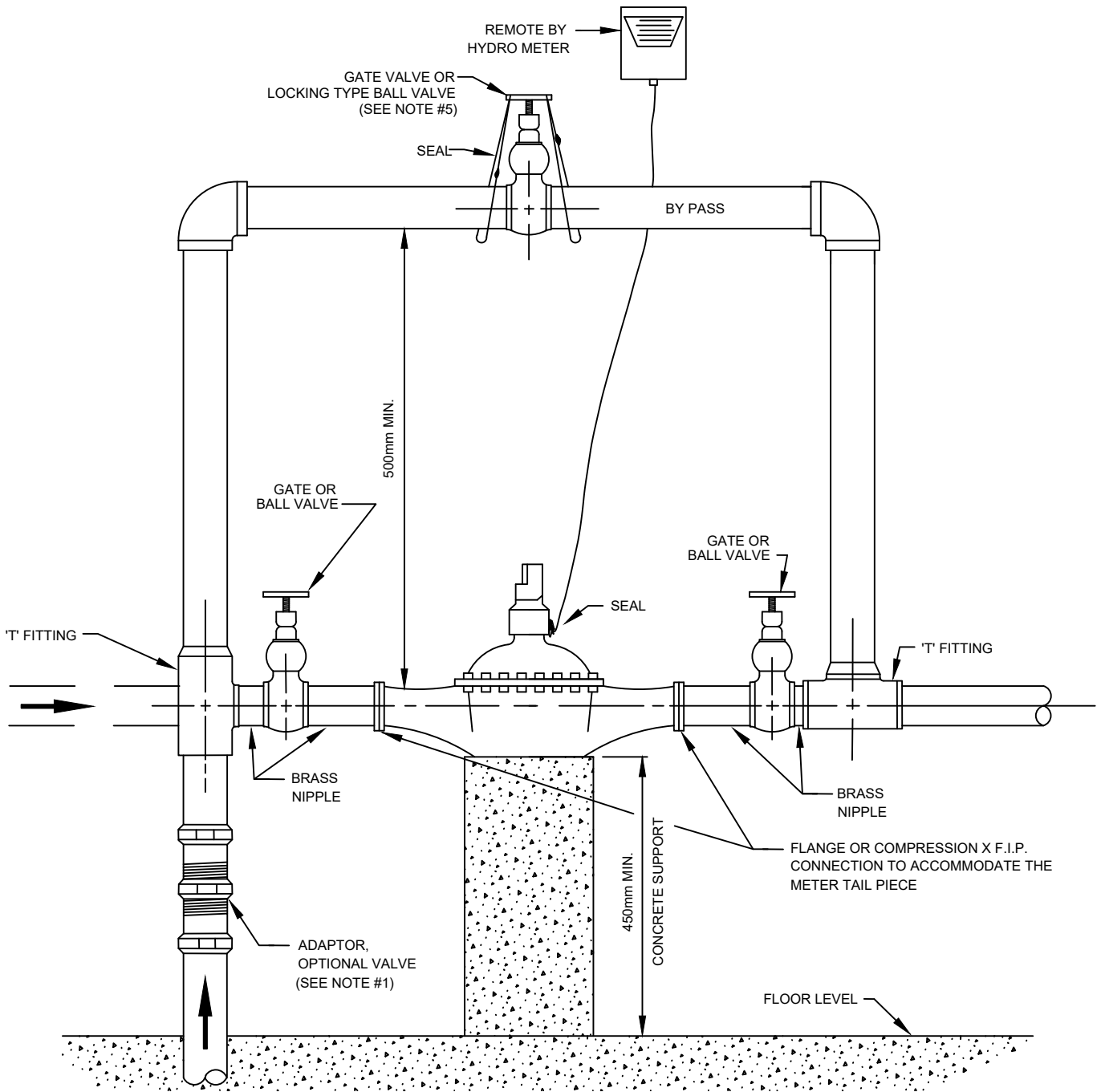

**NOTES:**

1. A BALL OR GATE VALVE MAY BE SUBSTITUTED WHERE THE ADAPTOR IS LOCATED. IF A VALVE IS NOT INSTALLED IN THIS LOCATION, SOLDERING WILL NOT BE ALLOWED BEFORE ANY CONTROLLING VALVE.
2. REMOTE TO BE MOUNTED ON HYDRO STACK OR INSIDE NEXT TO HYDRO METER.
3. ALL VALVES TO OPERATE CLOCKWISE TO CLOSE. NO SOLDERED JOINTS WILL BE ALLOWED BELOW VALVES.
4. BY-PASS CAN BE MOUNTED VERTICALLY OR HORIZONTALLY.
5. ALL MATERIALS AS SHOWN, SHALL BE SUPPLIED AND INSPECTED BY OTHERS.
6. BALL VALVE TO BE LOCKING TYPE IF USED ON BY-PASS.
7. CITY ENGINEERING PERSONNEL SHALL INSPECT INSTALLATION PRIOR TO TURNING ON WATER SUPPLY.
8. METER FLANGES MUST BE INSTALLED IN A MANNER WHICH THEY MAY BE EASILY ACCESSED FOR REPLACEMENT WITHOUT SOLDERING.
9. IMMEDIATELY AFTER THE WATER SERVICE PASSES UNDER THE FOOTING. IT HAS TO BE BROUGHT UP THROUGH THE FLOOR AND BE METERED AT THAT POINT.
10. ALL MATERIALS MUST CONFORM TO THE CURRENT ONTARIO BUILDING CODE, PART 7.



## STANDARD 50mm WATER METER INSTALLATION

ENGINEERING SERVICES  
DEPARTMENT

DATE: AUG. 1997

REV: NOV. 2021

W-102

N.T.S.

DRAWN BY:  
A. SCHOEN

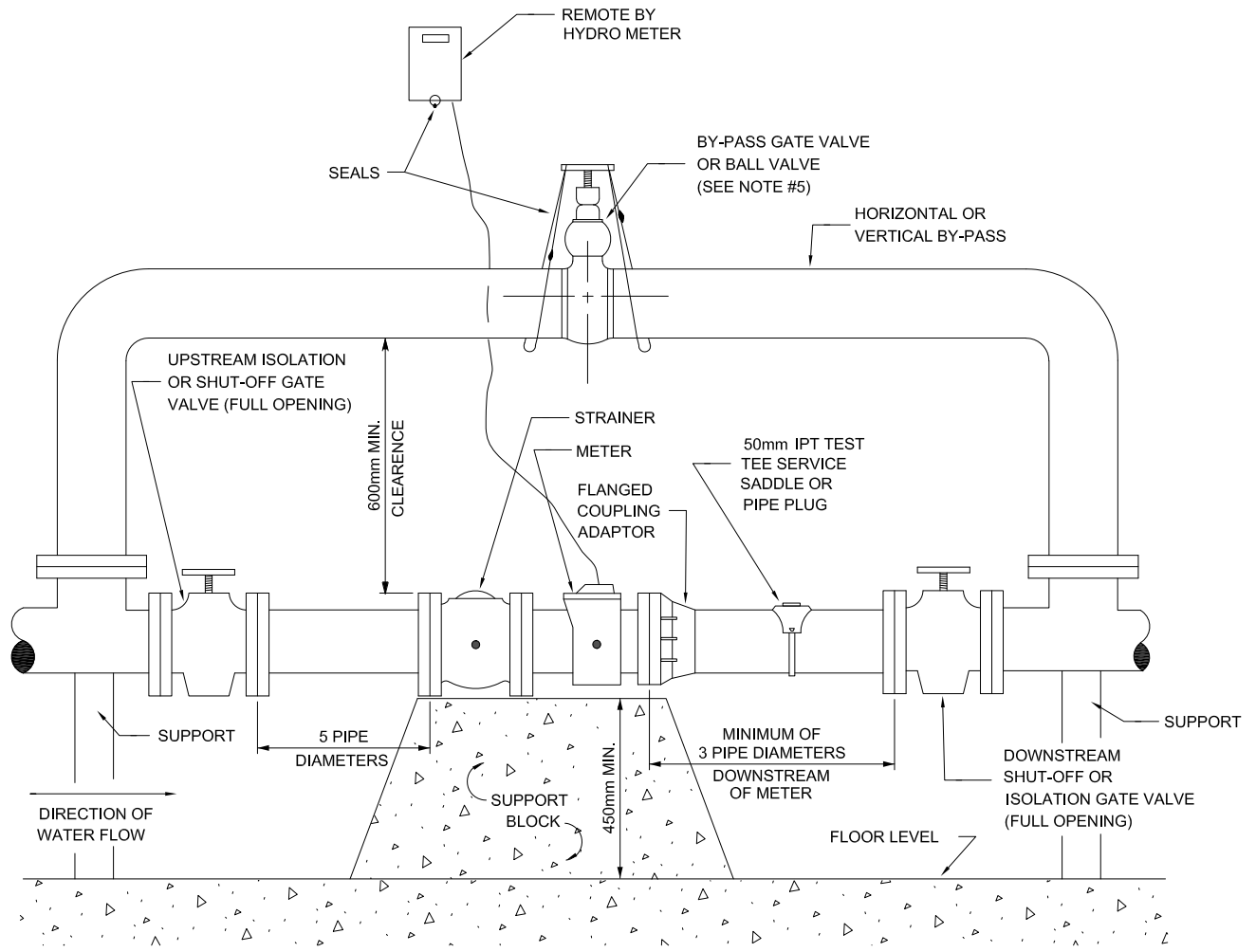

**NOTES:**

1. PROVISIONS ARE TO BE MADE FOR DISPOSAL OF WATER USED FOR INPLACE TESTING EITHER THROUGH A FLOOR DRAIN OR A 125mm FERRULE THROUGH WALL.
2. ALL GATE VALVES TO OPERATE CLOCKWISE TO CLOSE.
3. REMOTE METER TO BE MOUNTED OUTSIDE ON HYDRO STACK OR IN ELECTRICAL ROOM BY HYDRO METER.
4. ALL MATERIALS AS SHOWN, SHALL BE SUPPLIED AND INSTALLED BY OTHERS.
5. BALL VALVE TO BE LOCKING TYPE IF USED ON BY-PASS.
6. CITY ENGINEERING SHALL INSPECT INSTALLATION PRIOR TO TURNING ON WATER SUPPLY VALVE.
7. IMMEDIATELY AFTER THE WATER SERVICE PASSES UNDER THE FOOTING. IT HAS TO BE BROUGHT UP THROUGH THE FLOOR AND BE METERED AT THAT POINT.
8. ALL MATERIALS MUST CONFORM TO THE CURRENT ONTARIO BUILDING CODE, PART 7.



## STANDARD 75mm TURBINE METER INSTALLATION

ENGINEERING SERVICES  
DEPARTMENT

DATE: AUG. 1997

REV: NOV. 2021

N.T.S.

**W-103**

DRAWN BY:  
A. SCHOEN

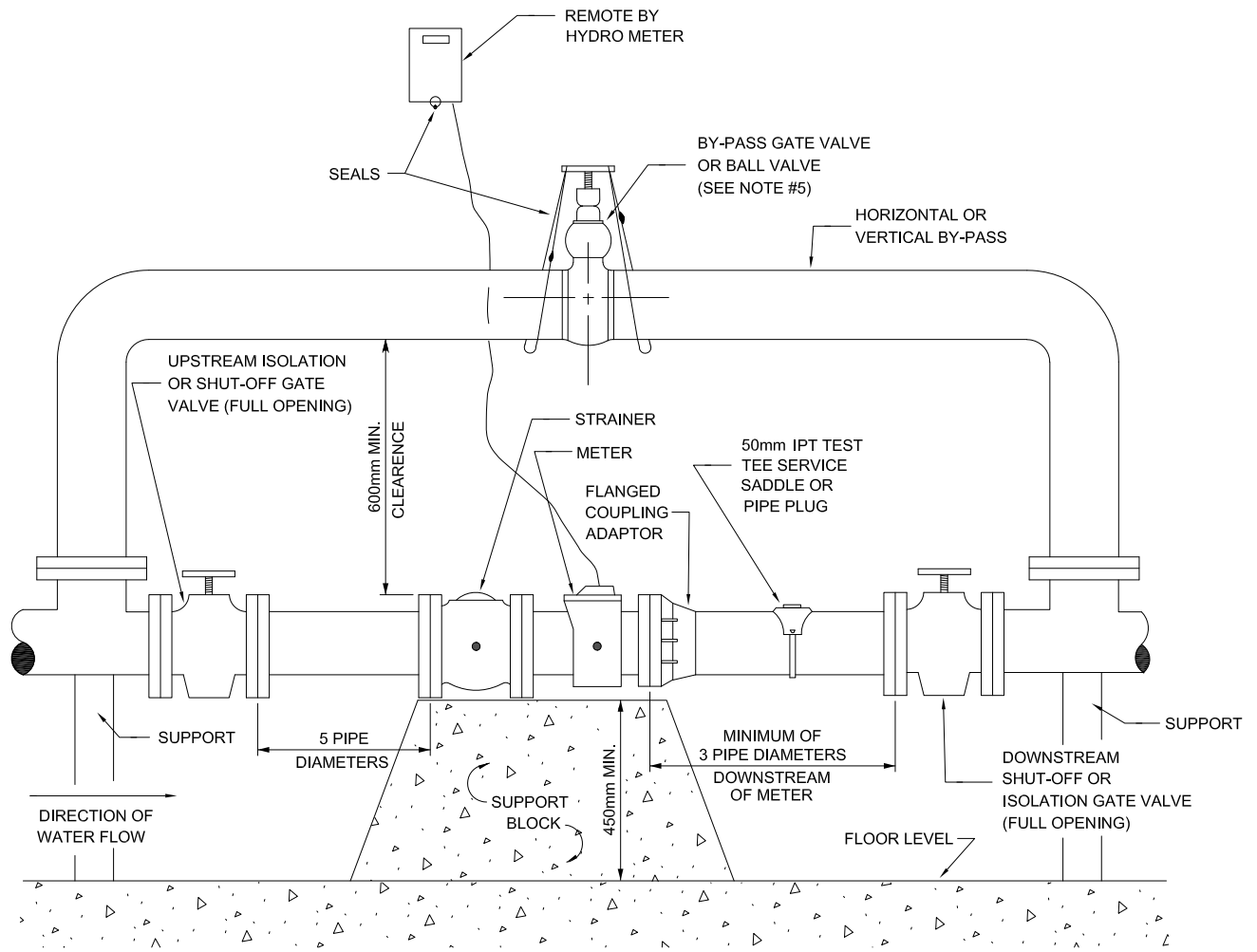

**NOTES:**

1. PROVISIONS ARE TO BE MADE FOR DISPOSAL OF WATER USED FOR INPLACE TESTING EITHER THROUGH A FLOOR DRAIN OR A 125mm FERRULE THROUGH WALL.
2. ALL GATE VALVES TO OPERATE CLOCKWISE TO CLOSE.
3. REMOTE METER TO BE MOUNTED OUTSIDE ON HYDRO STACK OR IN ELECTRICAL ROOM BY HYDRO METER.
4. ALL MATERIALS AS SHOWN, SHALL BE SUPPLIED AND INSTALLED BY OTHERS.
5. BALL VALVE TO BE LOCKING TYPE IF USED ON BY-PASS.
6. CITY ENGINEERING SHALL INSPECT INSTALLATION PRIOR TO TURNING ON WATER SUPPLY VALVE.
7. IMMEDIATELY AFTER THE WATER SERVICE PASSES UNDER THE FOOTING. IT HAS TO BE BROUGHT UP THROUGH THE FLOOR AND BE METERED AT THAT POINT.
8. ALL MATERIALS MUST CONFORM TO THE CURRENT ONTARIO BUILDING CODE, PART 7.



## STANDARD 100mm TURBINE METER INSTALLATION

ENGINEERING SERVICES DEPARTMENT

DATE: AUG. 1997

REV: NOV. 2021

N.T.S.

W-104

DRAWN BY:  
A. SCHOEN

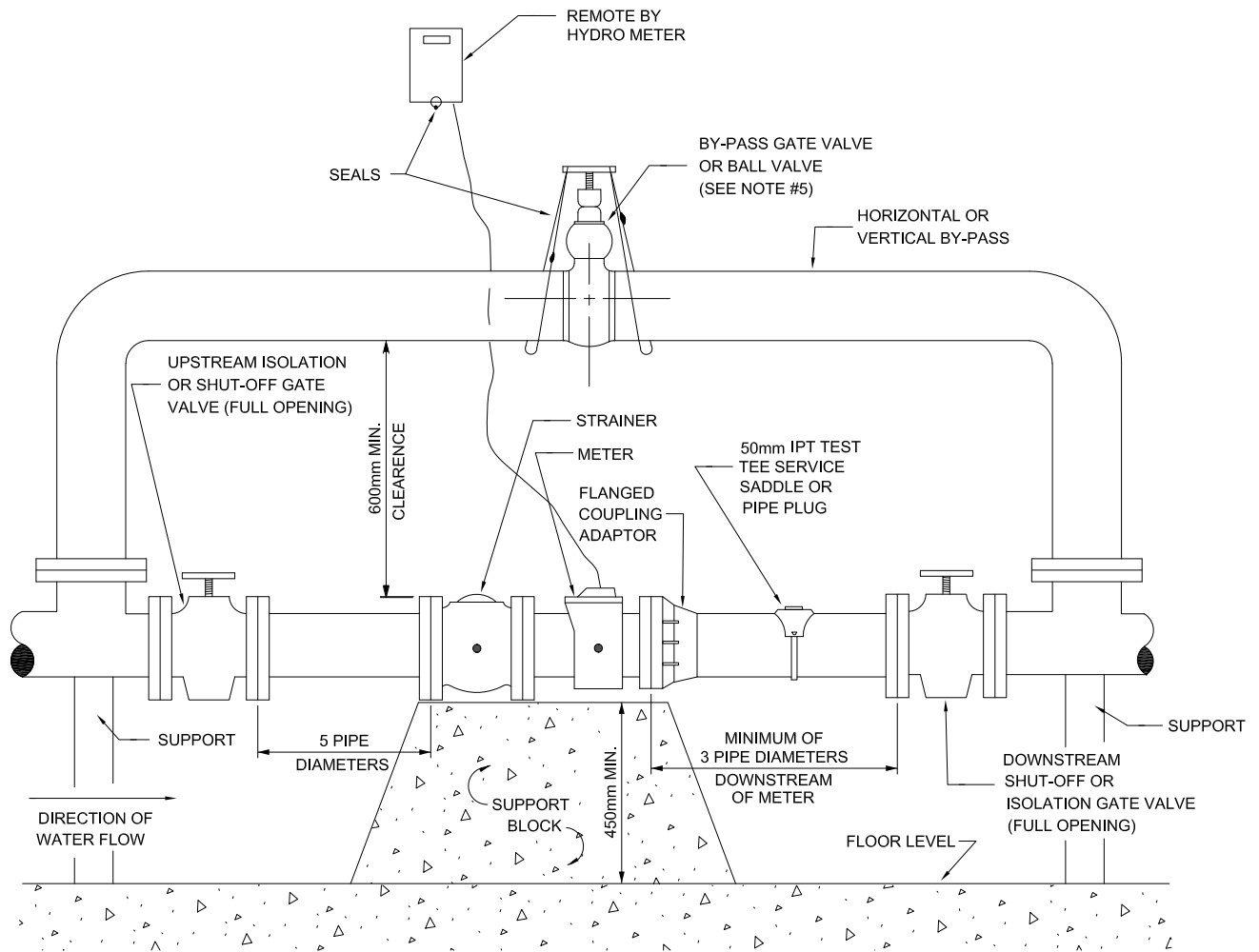

**NOTES:**

1. PROVISIONS ARE TO BE MADE FOR DISPOSAL OF WATER USED FOR INPLACE TESTING EITHER THROUGH A FLOOR DRAIN OR A 125mm FERRULE THROUGH WALL.
2. ALL GATE VALVES TO OPERATE CLOCKWISE TO CLOSE.
3. REMOTE METER TO BE MOUNTED OUTSIDE ON HYDRO STACK OR IN ELECTRICAL ROOM BY HYDRO METER.
4. ALL MATERIALS AS SHOWN, SHALL BE SUPPLIED AND INSTALLED BY OTHERS.
5. BALL VALVE TO BE LOCKING TYPE IF USED ON BY-PASS.
6. CITY ENGINEERING SHALL INSPECT INSTALLATION PRIOR TO TURNING ON WATER SUPPLY VALVE.
7. IMMEDIATELY AFTER THE WATER SERVICE PASSES UNDER THE FOOTING. IT HAS TO BE BROUGHT UP THROUGH THE FLOOR AND BE METERED AT THAT POINT.
8. ALL MATERIALS MUST CONFORM TO THE CURRENT ONTARIO BUILDING CODE, PART 7.



## STANDARD 150mm TURBINE METER INSTALLATION

ENGINEERING SERVICES  
DEPARTMENT

DATE: AUG. 1997

REV: NOV. 2021

**W-105**

N.T.S.

DRAWN BY:  
A. SCHOEN

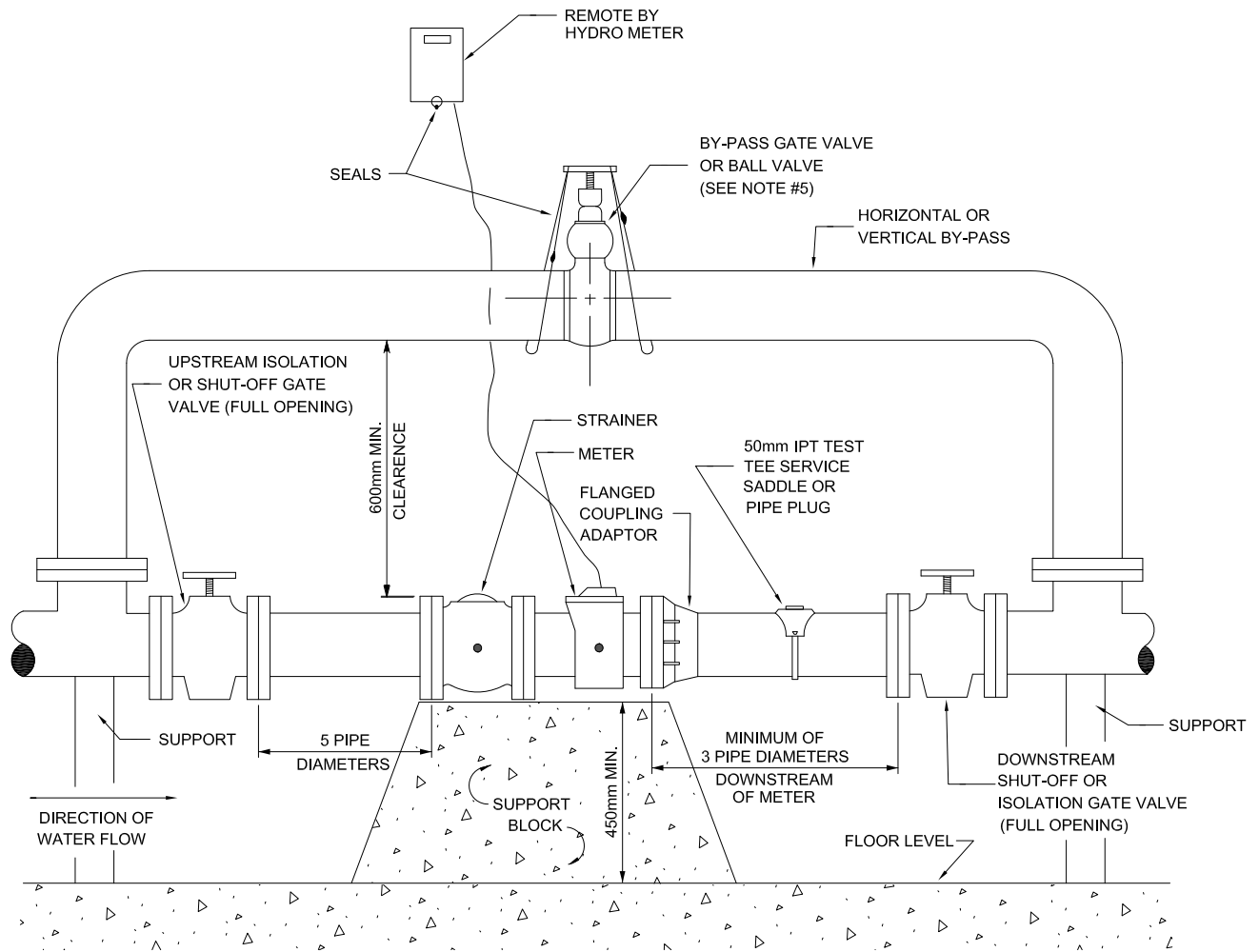

**NOTES:**

1. PROVISIONS ARE TO BE MADE FOR DISPOSAL OF WATER USED FOR INPLACE TESTING EITHER THROUGH A FLOOR DRAIN OR A 125mm FERRULE THROUGH WALL.
2. ALL GATE VALVES TO OPERATE CLOCKWISE TO CLOSE.
3. REMOTE METER TO BE MOUNTED OUTSIDE ON HYDRO STACK OR IN ELECTRICAL ROOM BY HYDRO METER.
4. ALL MATERIALS AS SHOWN, SHALL BE SUPPLIED AND INSTALLED BY OTHERS.
5. BALL VALVE TO BE LOCKING TYPE IF USED ON BY-PASS.
6. CITY ENGINEERING SHALL INSPECT INSTALLATION PRIOR TO TURNING ON WATER SUPPLY VALVE.
7. IMMEDIATELY AFTER THE WATER SERVICE PASSES UNDER THE FOOTING. IT HAS TO BE BROUGHT UP THROUGH THE FLOOR AND BE METERED AT THAT POINT.
8. ALL MATERIALS MUST CONFORM TO THE CURRENT ONTARIO BUILDING CODE, PART 7.



## STANDARD 200mm TURBINE METER INSTALLATION

ENGINEERING SERVICES  
DEPARTMENT

DATE: AUG. 1997

REV: NOV. 2021

N.T.S.

**W-106**

DRAWN BY:  
A. SCHOEN

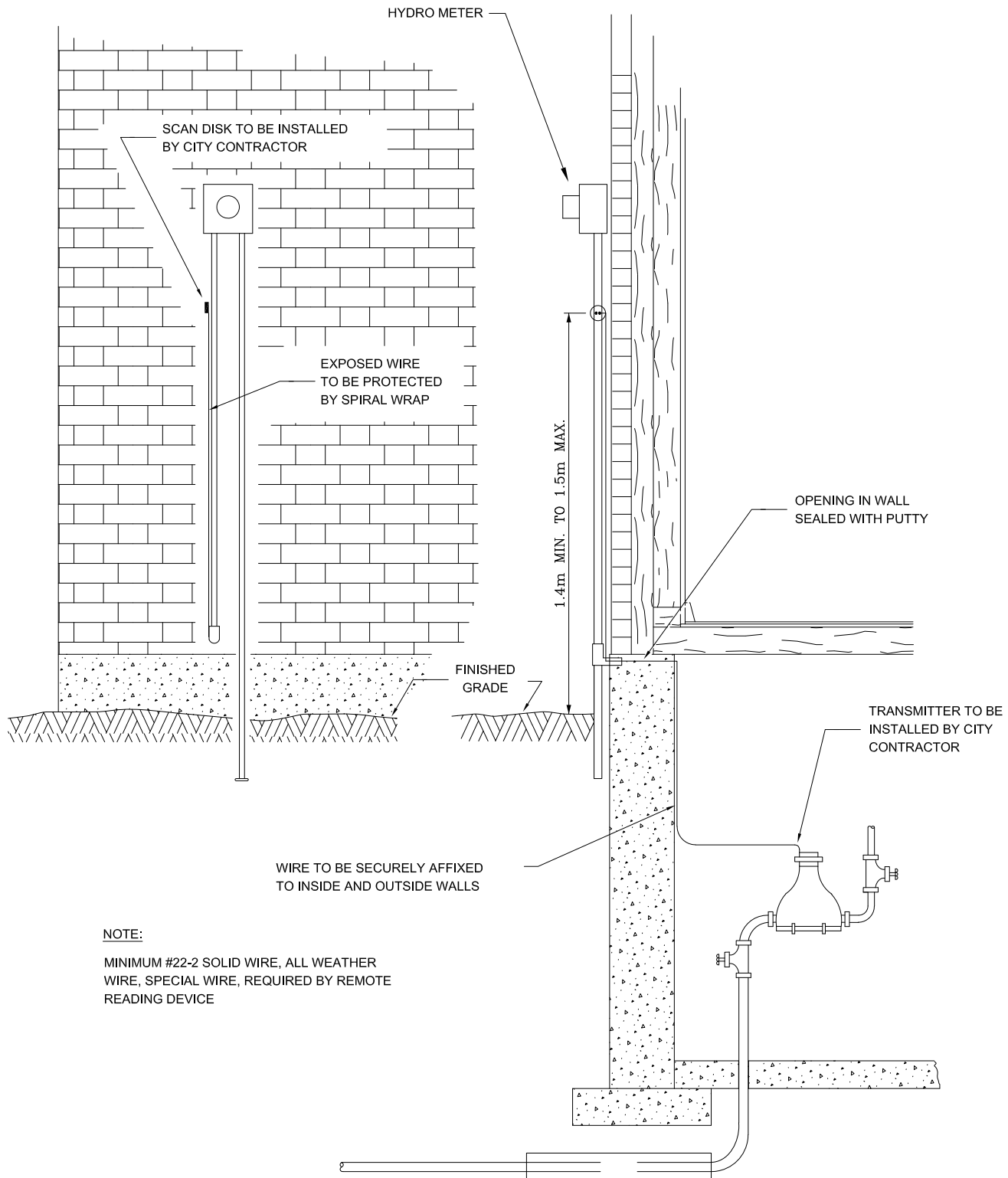

**NOTE:**

MINIMUM #22-2 SOLID WIRE, ALL WEATHER WIRE, SPECIAL WIRE, REQUIRED BY REMOTE READING DEVICE



# TRANSMITTER AND SCAN DISC INSTALLATION

ENGINEERING SERVICES DEPARTMENT

DATE: MAR. 1987

REV: NOV. 2021

**W-107**

N.T.S.

DRAWN BY:  
A. SCHOEN

**NOTES:**

1. NO GROUND CONNECTIONS TO WATER.  
PIPE BETWEEN DIELECTRIC INSULATOR AND CURBSTOP.
2. MAINTAIN A MINIMUM CLEARANCE OF 5'-0" BETWEEN ANY NON-INSULATED GROUNDING CONDUCTOR OR GROUNDING CONNECTIONS AND THE DIELECTRIC INSULATOR.

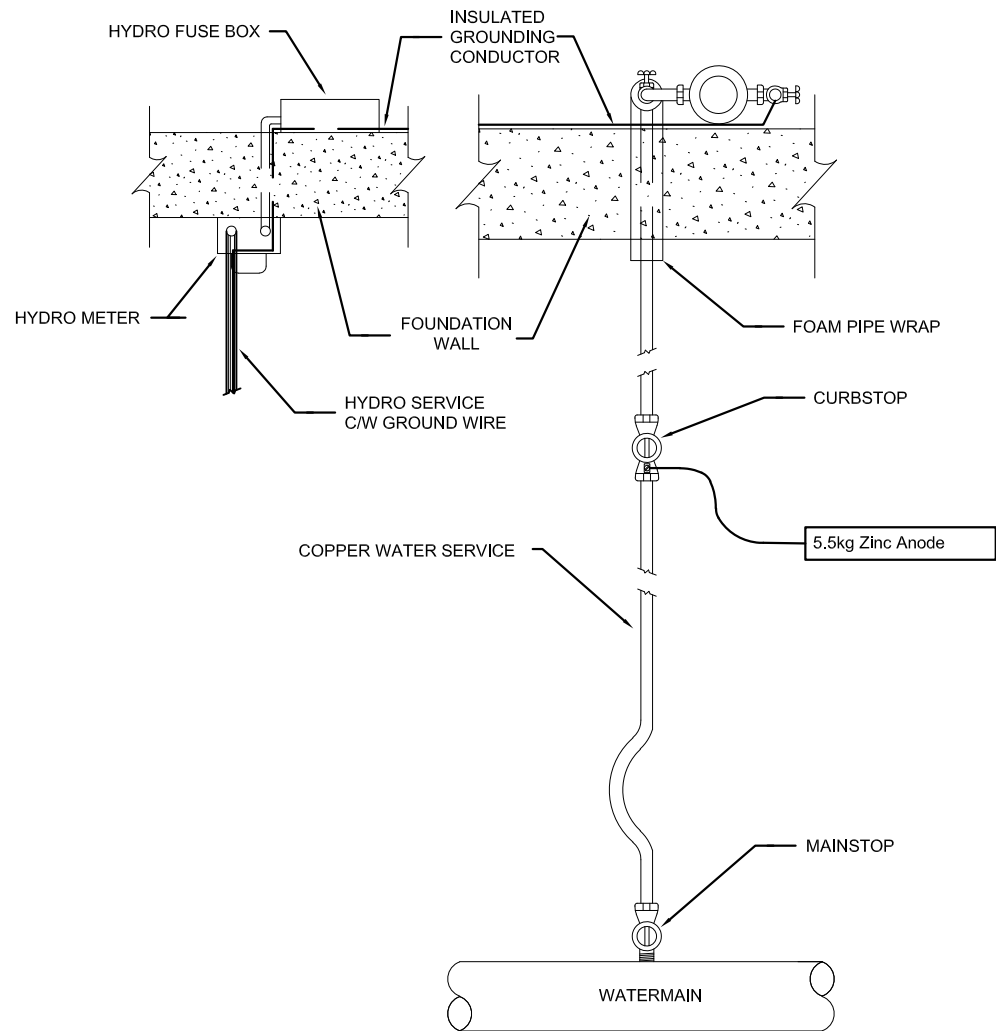
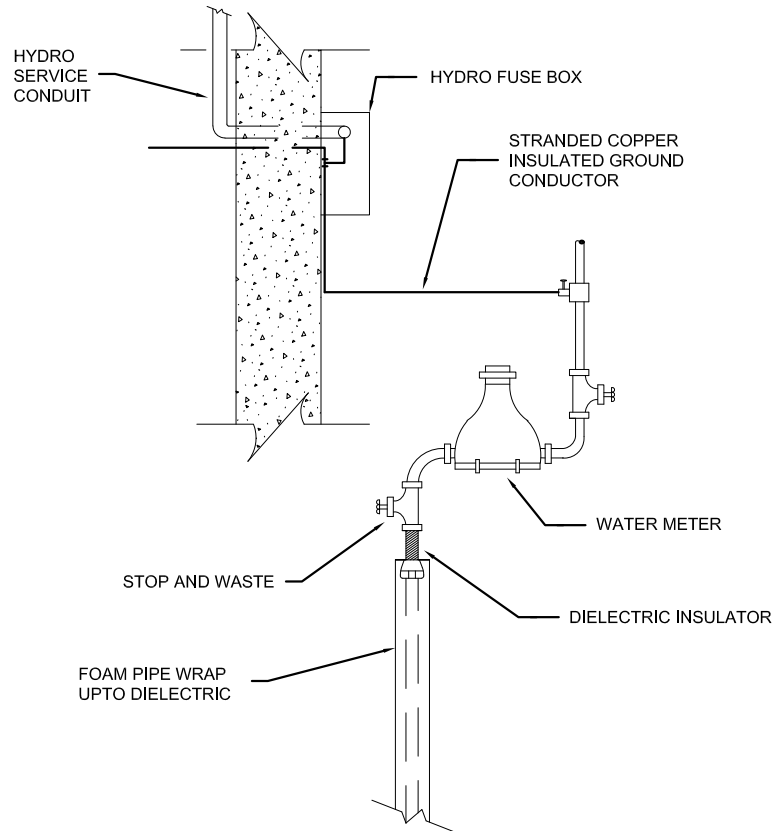

**GROUND WIRE CONNECTIONS  
FOR NEW SERVICES**

ENGINEERING SERVICES  
DEPARTMENT

DATE: JULY 1989

REV: NOV. 2021

N.T.S.

**W-108**

DRAWN BY:  
A. SCHOEN

**NOTES: NO GROUNDING WIRES BEFORE WATER METER**

1. 100 amp HYDRO SERVICE GROUND WIRE, AND ANODE WIRE SHALL BE #6 GAUGE COPPER N.M.W. CONDUCTOR.
2. 200 amp HYDRO SERVICE GROUND WIRE, AND ANODE WIRE SHALL BE #2 GAUGE COPPER N.M.W. CONDUCTOR.
3. ALL GROUND WIRE CONNECTIONS WILL BE SLEEVED, AND SEALED WITH HEAT SHRINK TUBE.

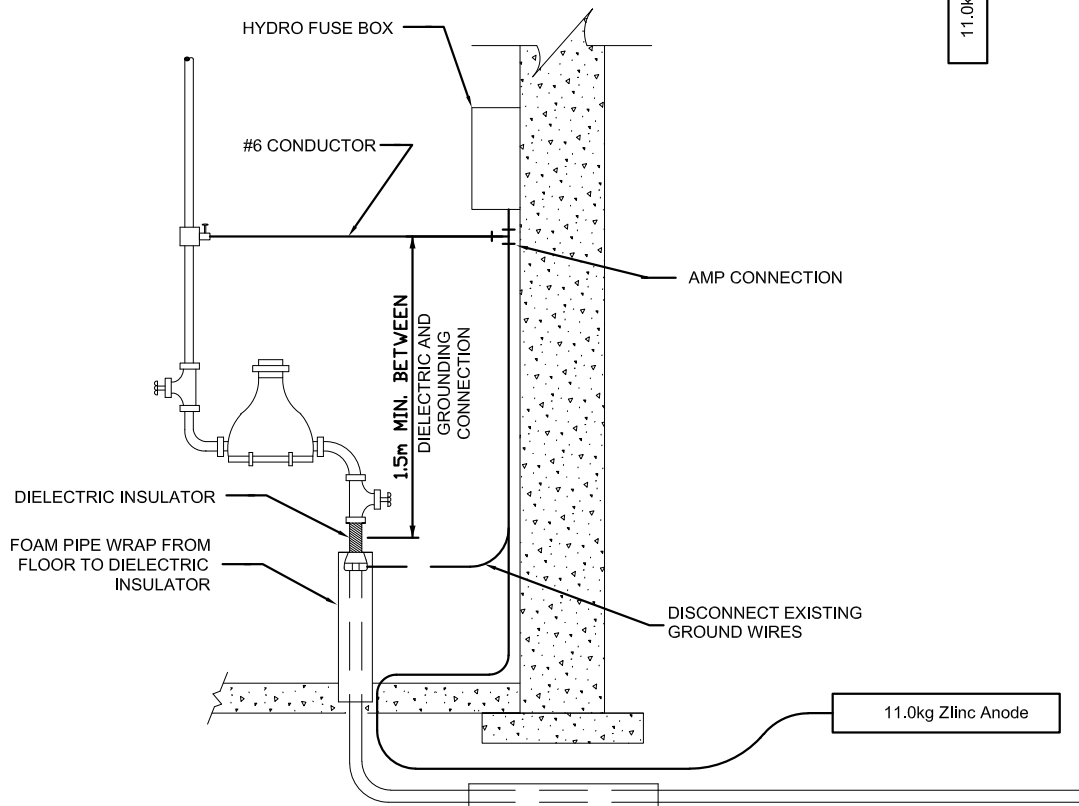
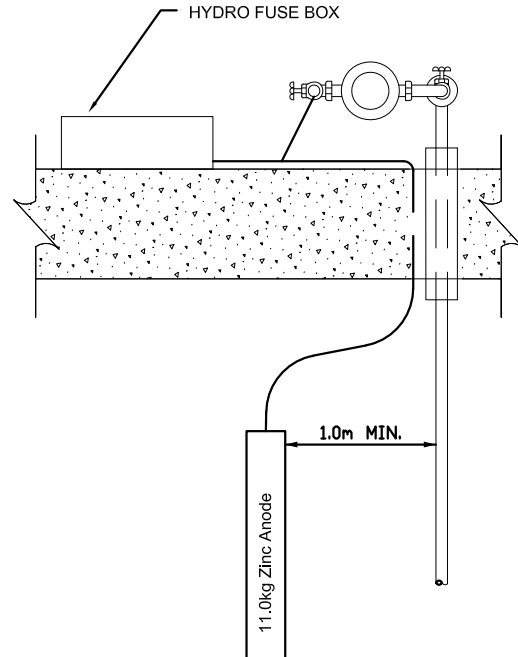

**GROUND WIRE CONNECTIONS FOR NEW SERVICES**

ENGINEERING SERVICES DEPARTMENT

DATE: MAR. 1987

REV: NOV. 2021

N.T.S.

**W-109**

DRAWN BY:  
A. SCHOEN



NOTE: IF A HIGH HAZARD BACKFLOW PREVENTOR(BFP) IS REQUIRED, THE BFP WILL HAVE TO BE INSTALLED IN ACCORDANCE TO THE LATEST VERSION OF THE CSA STANDARD B64.10

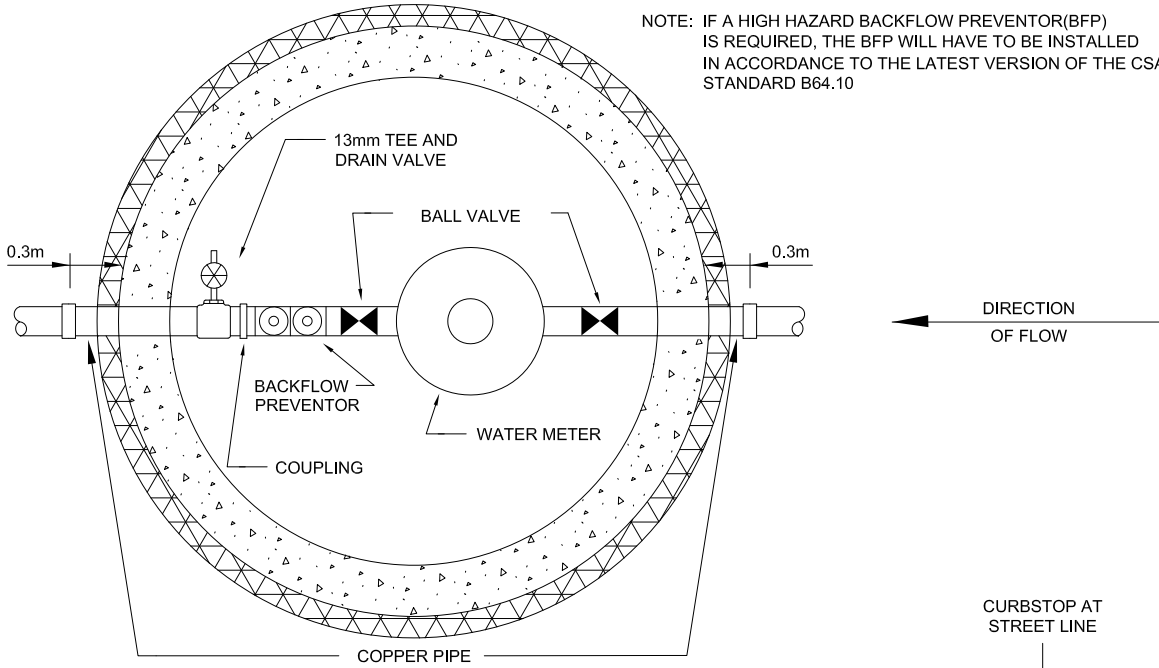

50mm SM RIGID STYROFOAM

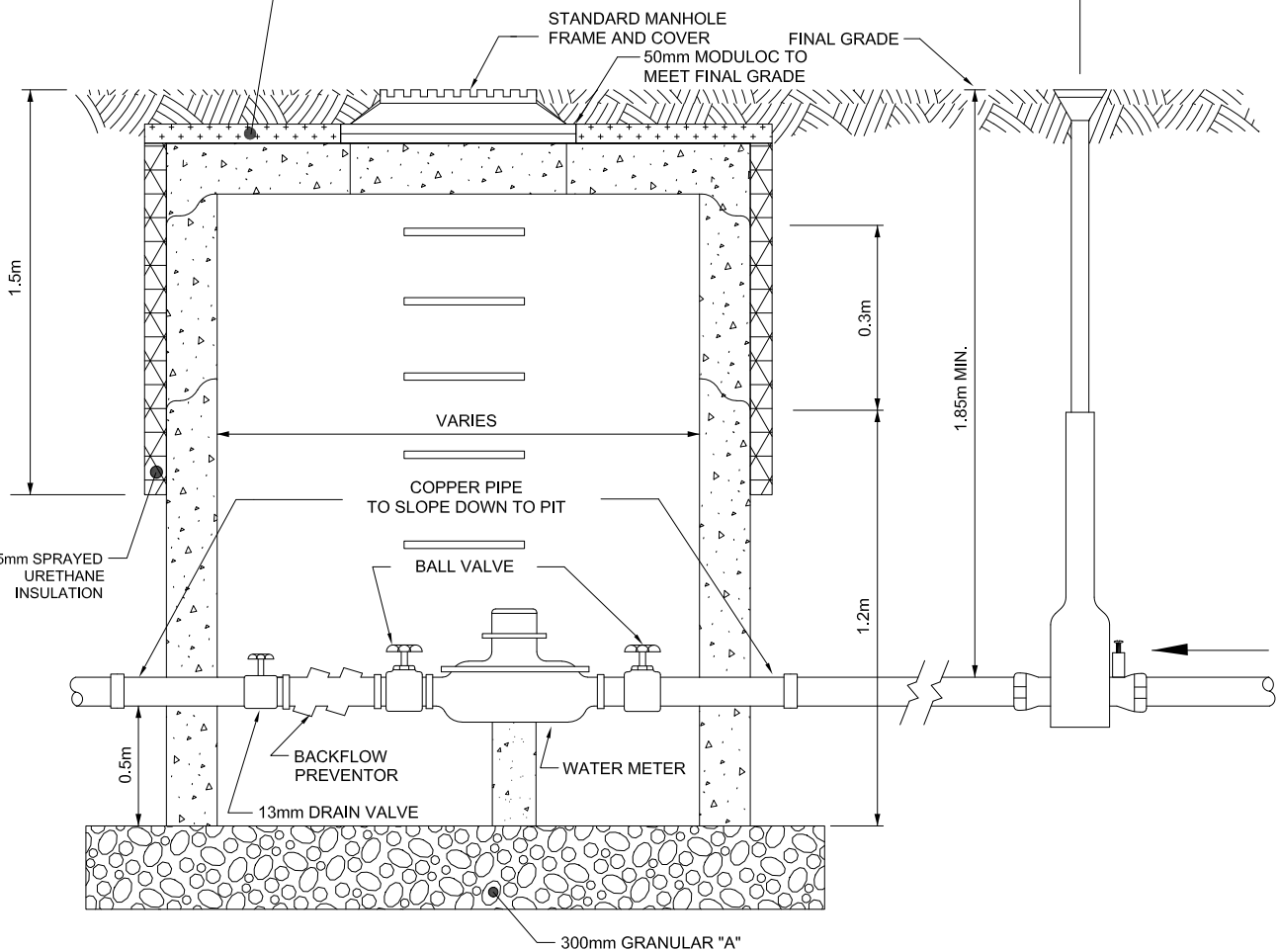

CURBSTOP AT STREET LINE



## TYPICAL METER CHAMBER

ENGINEERING SERVICES  
DEPARTMENT

DATE: MAY 1989

REV: NOV. 2021

N.T.S.

W-110

DRAWN BY:  
A. SCHOEN

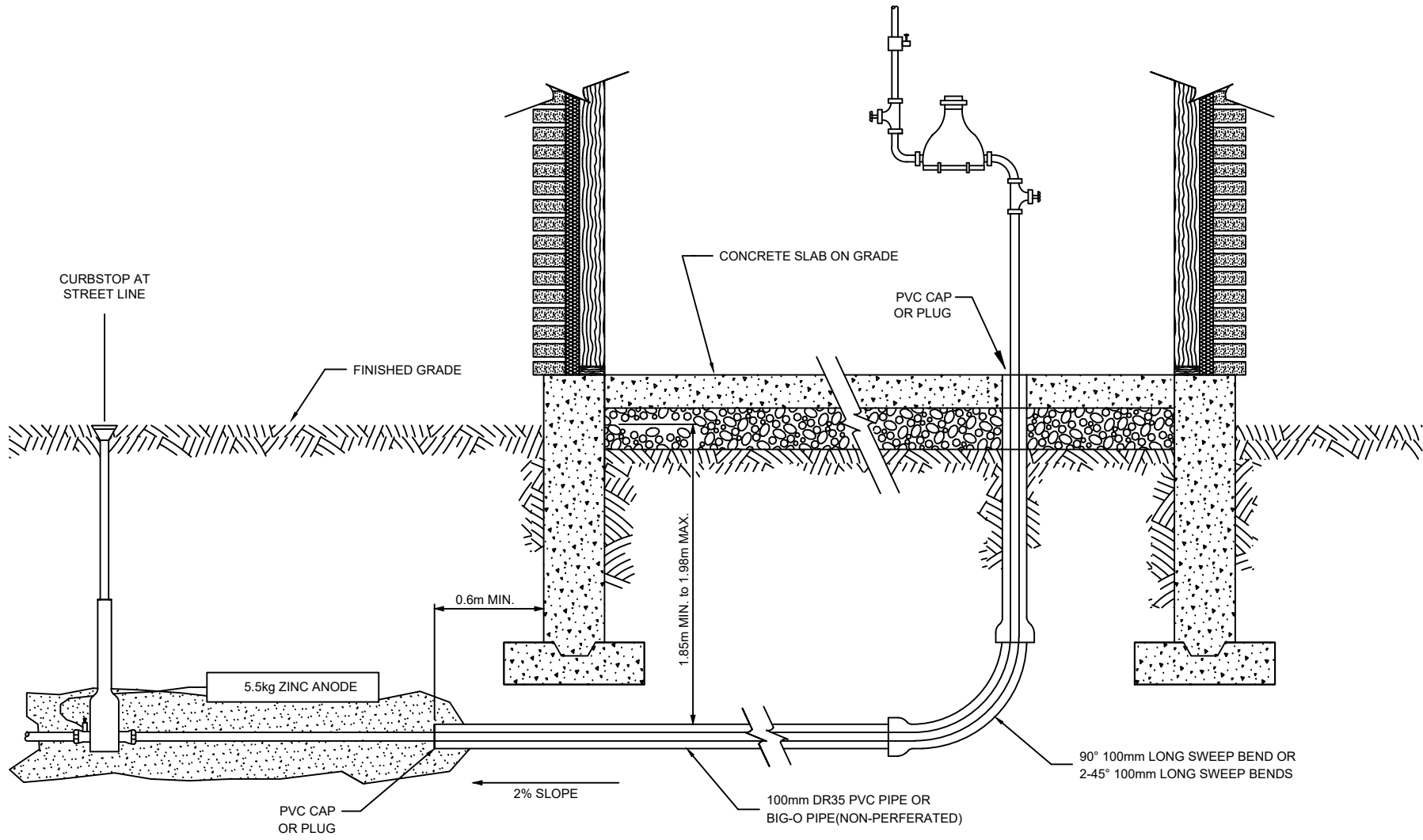

**TYPICAL WATER SERVICE  
INSTALLATION THROUGH  
UNEXCAVATED AREA PASSED  
FOOTINGS**

ENGINEERING SERVICES DEPARTMENT	
DATE: JAN. 1994	
REV: NOV. 2021	
<b>W-111</b>	DRAWN BY: A. SCHOEN

T:\WATER STANDARD DRAWING\SPECW100\REVISIONS\W-111(REV).DWG

### ATMOSPHERIC VACUUM BREAKER (AVB)

1. One AVB required for each irrigation zone; no control valves (on/offvalves) allowed downstream of an AVB.
2. Each AVB must be installed a minimum of 150mm (6") above the highest piping in the zone it serves.
3. No chemical or fertilizer may be introduced through an irrigation system equipped with AVBs.

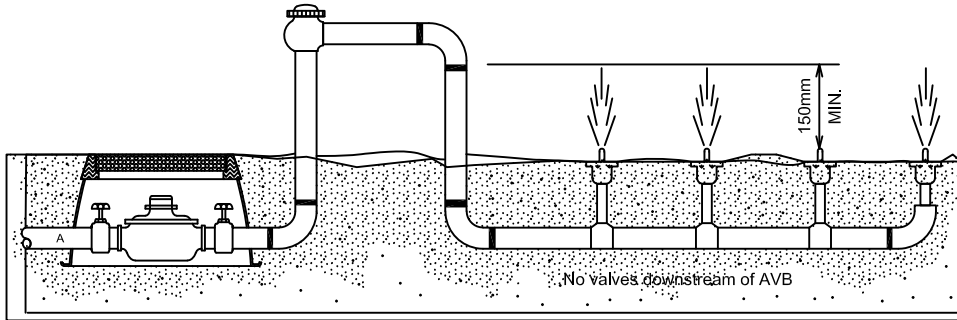

### DOUBLE CHECK VALVE ASSEMBLY (DCVA)

1. Only one DCVA is required to serve the whole system; control valves can be located downstream of the DCVA.
2. DCVAs may be installed below ground level in an enclosure that provides a minimum of 150mm (6") of clearance on all sides of the DCVA. Consult your local water supplier for approval.
3. DCVAs must be tested by a Province-certified Backflow Device Tester: (a) when installed; (b) annually; and (c) when moved or repaired.
4. No chemical or fertilizer may be introduced through an irrigation system equipped with DCVAs.

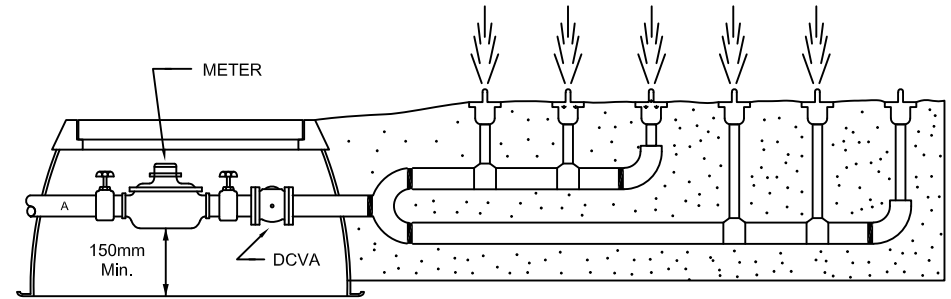

### PRESSURE VACUUM BREAKER ASSEMBLY (PVBA)

1. Only one PVB required to serve the whole system; control valves can be located downstream of the PVB.
2. PVB must be installed a minimum of 300mm (12") above the highest piping it serves.
3. PVBA's must be tested by a province-certified Backflow Device Tester: (a) when installed; (b) annually; and (c) when moved or repaired.
4. No chemical or fertilizer may be introduced through an irrigation system equipped with PVBs.

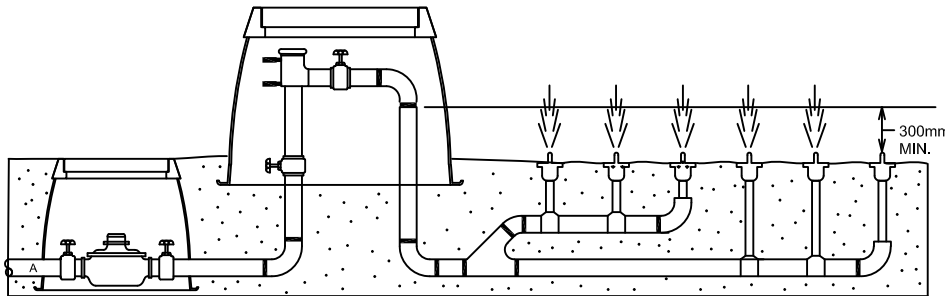

### REDUCED PRESSURE BACKFLOW ASSEMBLY (RPBA)

1. Only one RP is required to serve the whole system; control valves can be located downstream of the RP.
2. RP must be installed a minimum of 300mm (12") above ground level.
3. RP must be tested by a Province-certified Backflow Device Tester: (a) when installed; (b) annually; and (c) when moved or repaired.
4. In an RP-equipped system, fertilizer and other agricultural chemicals may be introduced downstream of the RP.

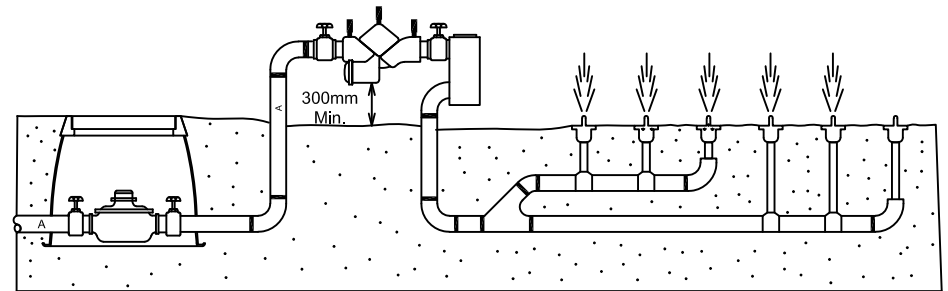

## BACKFLOW PREVENTION ON EXTERNAL IRRIGATION SYSTEMS

ENGINEERING SERVICES  
DEPARTMENT

DATE: SEPT. 1997

REV: NOV. 2021

W-112

N.T.S.

DRAWN BY:  
A. SCHOEN

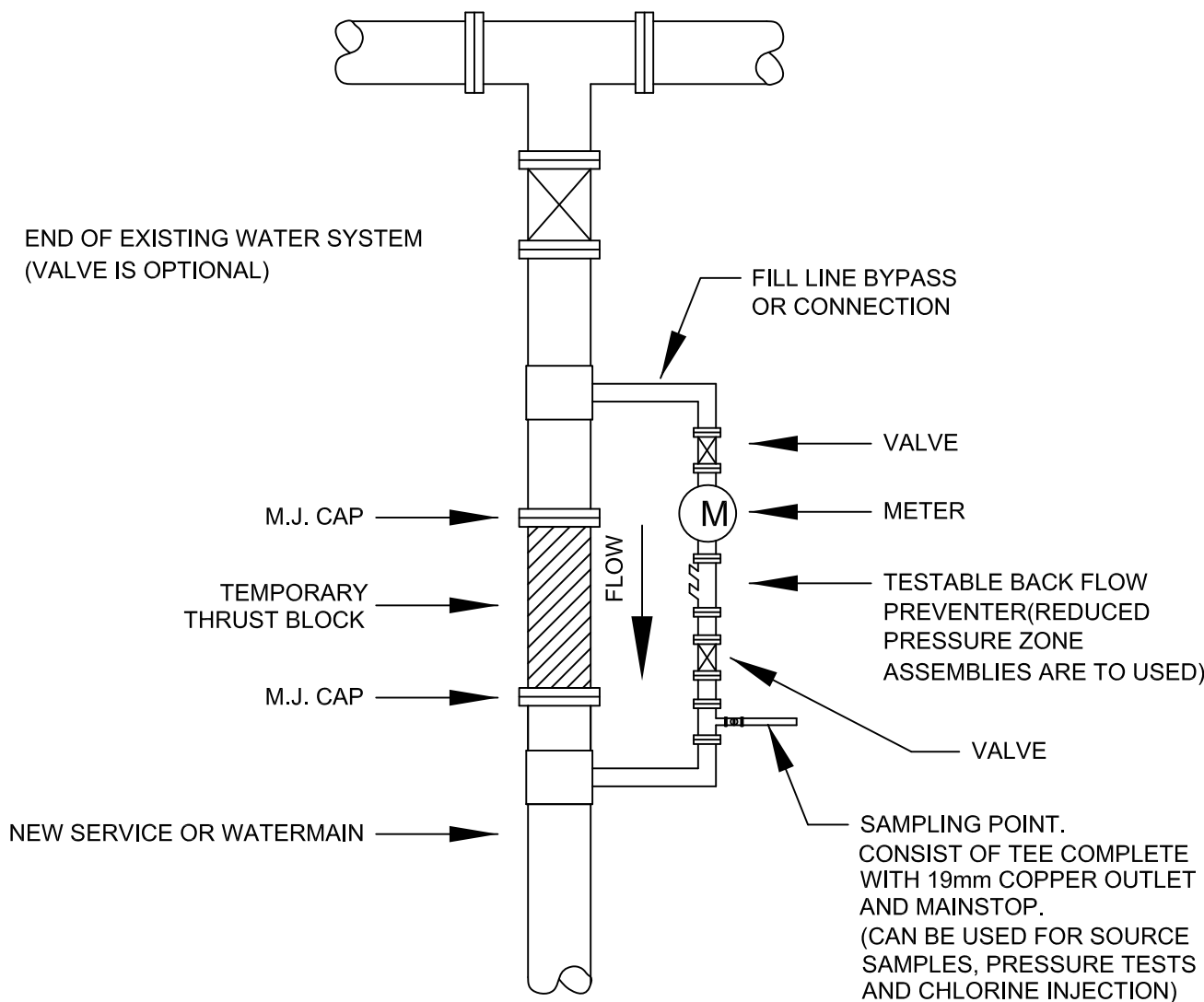

- NOTE:
- 1) THIS DRAWING IS A TYPICAL PERMANENT CONNECTION. THERE WILL BE MANY VARIATIONS OF THIS STANDARD DRAWING AND EACH APPLICATION WILL HAVE TO BE APPROVED BY THE CORPORATION'S ENGINEER.
  - 2) THE CONTRACTOR WILL HAVE TO HAVE THE BACKFLOW DEVICE TESTED BY A QUALIFIED TESTER EACH INSTALLATION AND EACH TIME IT IS RELOCATED. ALL TEST RECORDS ARE TO BE SUBMITTED TO THE CORPORATION'S INSPECTOR.
  - 3) BACKFLOW PREVENTER MAY BE REQUIRED TO BE REMOVED BEFORE PRESSURE TESTING PRIVATE SERVICING THAT REQUIRE A 200PSI PRESSURE TEST.
  - 4) PHYSICAL SUPPORT MUST BE SUPPLIED FOR METER AND BACKFLOW DEVICE. BACKFLOW DEVICE MUST BE PROTECTED FROM FREEZING.
  - 5) ON 200mm OR GREATER DIAMETER WATERMAINS, MINIMUM 100mm BACKFLOW SIZE REQUIRED.
  - 6) BACKFLOW TO REMAIN INSTALLED UNTIL FINAL CONNECTION.
  - 7) FEED PIPE MATERIAL CANNOT BE STEEL.
  - 8) COPPER USED FOR SAMPLING POINT WILL BE NEW FOR EACH APPLICATION.
  - 9) 6m MAXIMUM DISTANCE BETWEEN THE OLD PIPE AND NEW PIPE.



**TEMPORARY CONNECTION OF  
NEW WATERMAINS OR SERVICES  
(100mm OR LARGER) TO THE  
EXISTING WATER SYSTEM**

ENGINEERING SERVICES DEPARTMENT	
DATE: JULY 2001	N.T.S.
REV: JAN. 2024	
<b>W-113A</b>	DRAWN BY: J. RATANAVANH

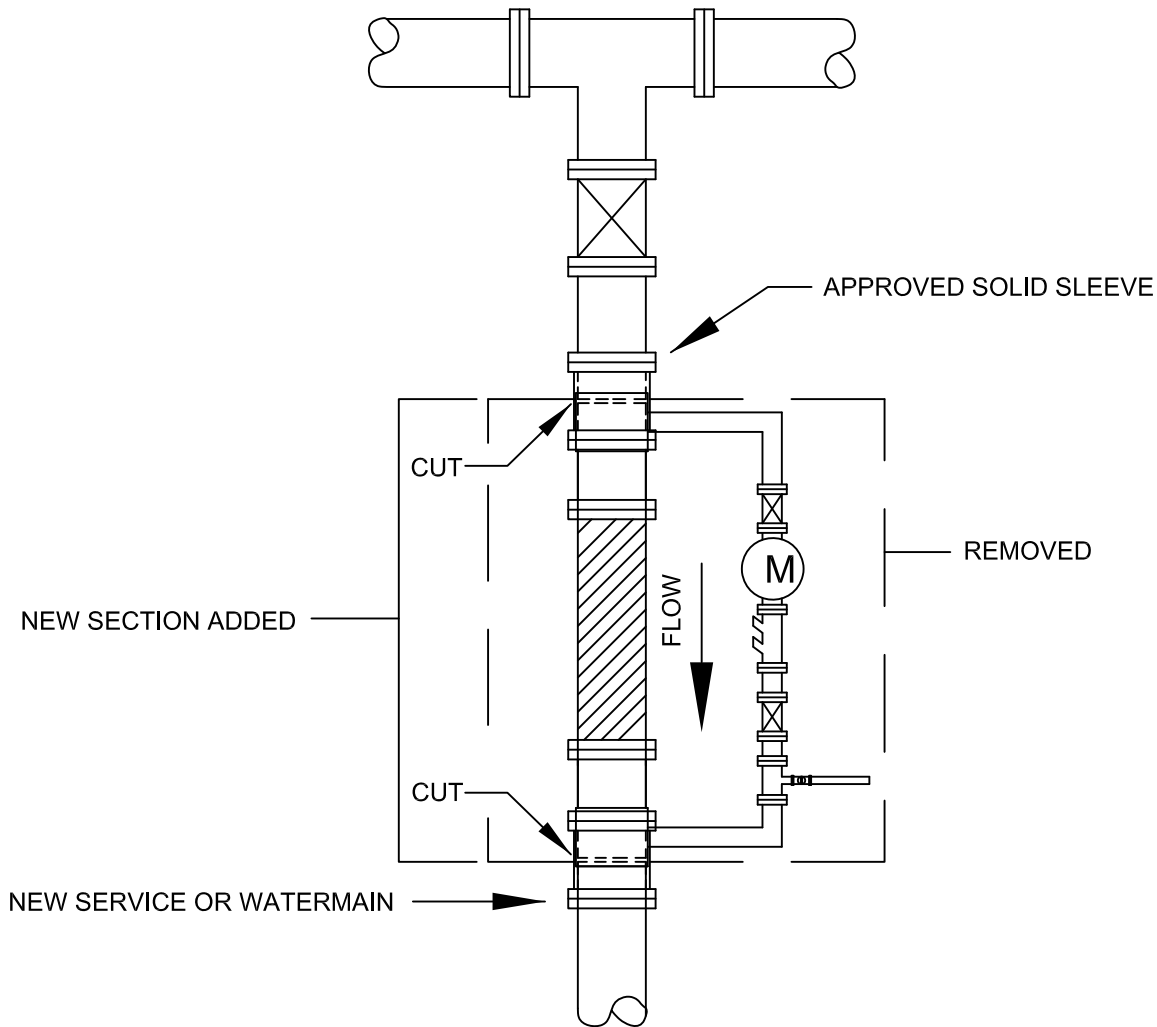

NOTE: ONCE THE CORPORATION'S INSPECTOR AUTHORIZES THE CONNECTION OF THE NEW WATERMAIN TO THE EXISTING WATER SYSTEM, THE TAP SECTIONS OF THE MAIN FOR THE JUMPER LINE SHALL BE CUT OFF AT THE INDICATED LOCATIONS, THE JUMPER LINE REMOVED AND A NEW SECTION OF MAIN DISINFECTED AND INSTALLED.



**FINAL CONNECTION OF NEW WATERMANS OR SERVICES (100mm OR LARGER) TO THE EXISTING WATER SYSTEM**

ENGINEERING SERVICES DEPARTMENT

DATE: JULY 2001  
REV: NOV. 2021

N.T.S.

**W-113B**

DRAWN BY:  
J. RATANAVANH

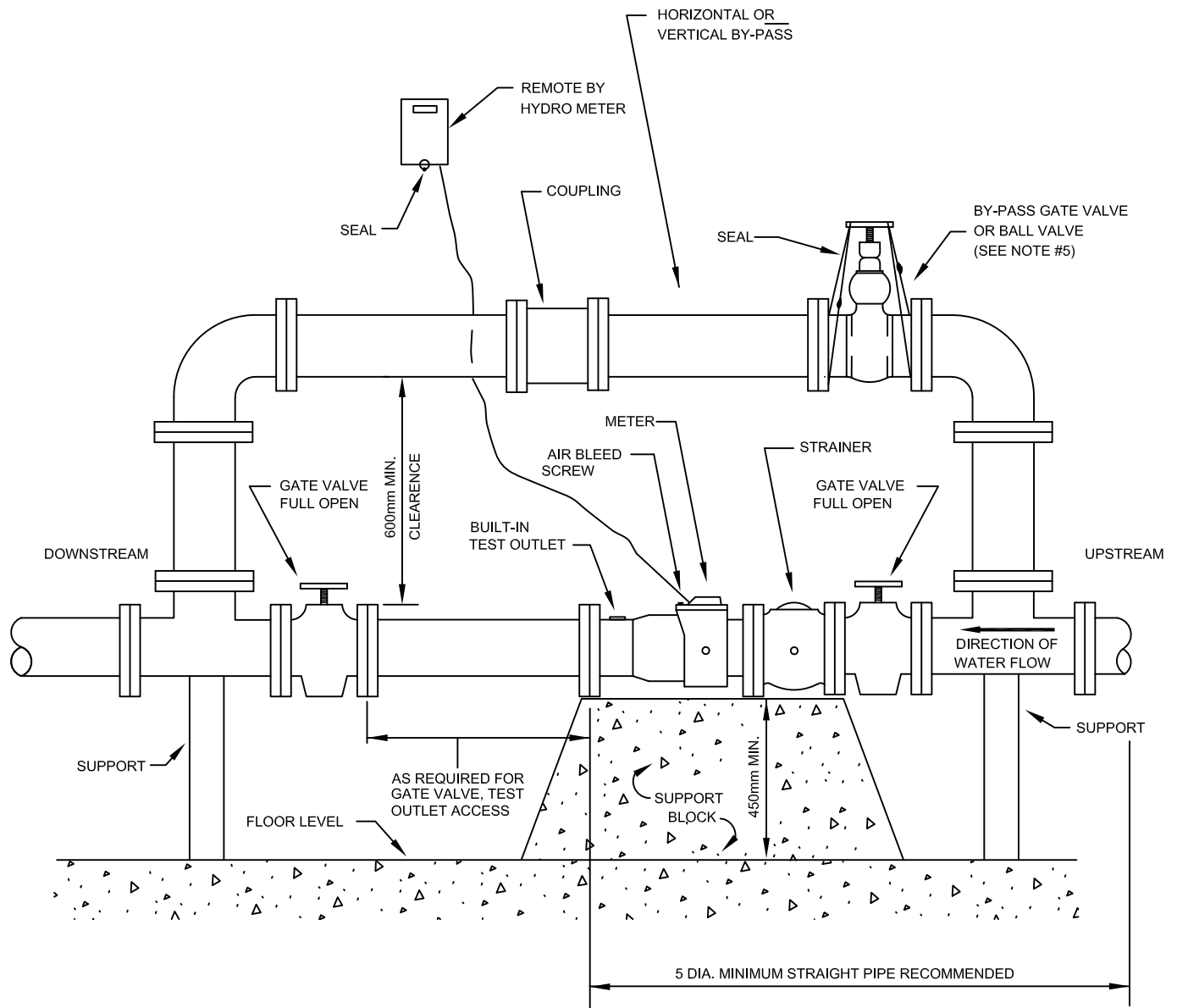

**NOTES:**

1. PROVISIONS ARE TO BE MADE FOR DISPOSAL OF WATER USED FOR INPLACE TESTING EITHER THROUGH A FLOOR DRAIN OR A 125mm FERRULE THROUGH WALL.
2. ALL GATE VALVES TO OPERATE CLOCKWISE TO CLOSE.
3. REMOTE METER TO BE MOUNTED OUTSIDE ON HYDRO STACK OR IN ELECTRICAL ROOM BY HYDRO METER.
4. ALL MATERIALS AS SHOWN, SHALL BE SUPPLIED AND INSTALLED BY OTHERS.
5. BALL VALVE TO BE LOCKING TYPE IF USED ON BY-PASS.
6. CITY ENGINEERING SHALL INSPECT INSTALLATION PRIOR TO TURNING ON WATER SUPPLY VALVE.
7. IMMEDIATELY AFTER THE WATER SERVICE PASSES UNDER THE FOOTING. IT HAS TO BE BROUGHT UP THROUGH THE FLOOR AND BE METERED AT THAT POINT.
8. ALL MATERIALS MUST CONFORM TO THE CURRENT ONTARIO BUILDING CODE, PART 7.



## STANDARD COMPOUND METER INSTALLATION

ENGINEERING SERVICES  
DEPARTMENT

REV: SEPT. 2003

DATE: NOV. 2021

**W-114**

N.T.S.

DRAWN BY:  
J. RATANAVANH

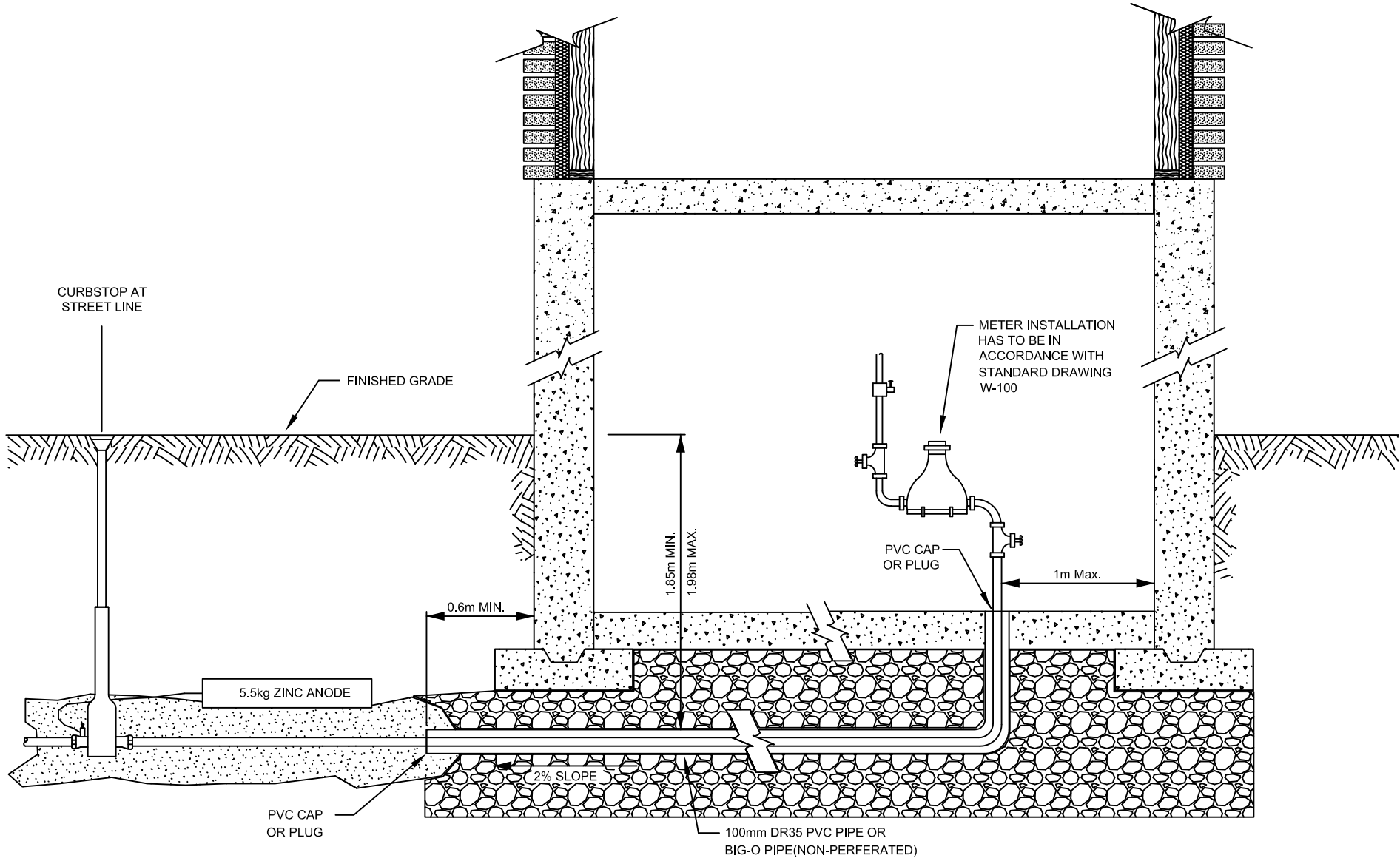

- NOTE: 1) METER TO BE INSTALLED IN HEATED AREA, WITHIN THE BUILDING.  
 2) "NO COUPLINGS" UNDER FLOOR OR FOOTINGS



**TYPICAL NEW WATER SERVICE  
 INSTALLATION THROUGH  
 EXCAVATED AREA PASSED  
 FOOTINGS**

ENGINEERING SERVICES  
 DEPARTMENT

DATE: APRIL 2004

REV: NOV. 2021

**W-115**

N.T.S.

DRAWN BY:  
 J. RATANAVANH

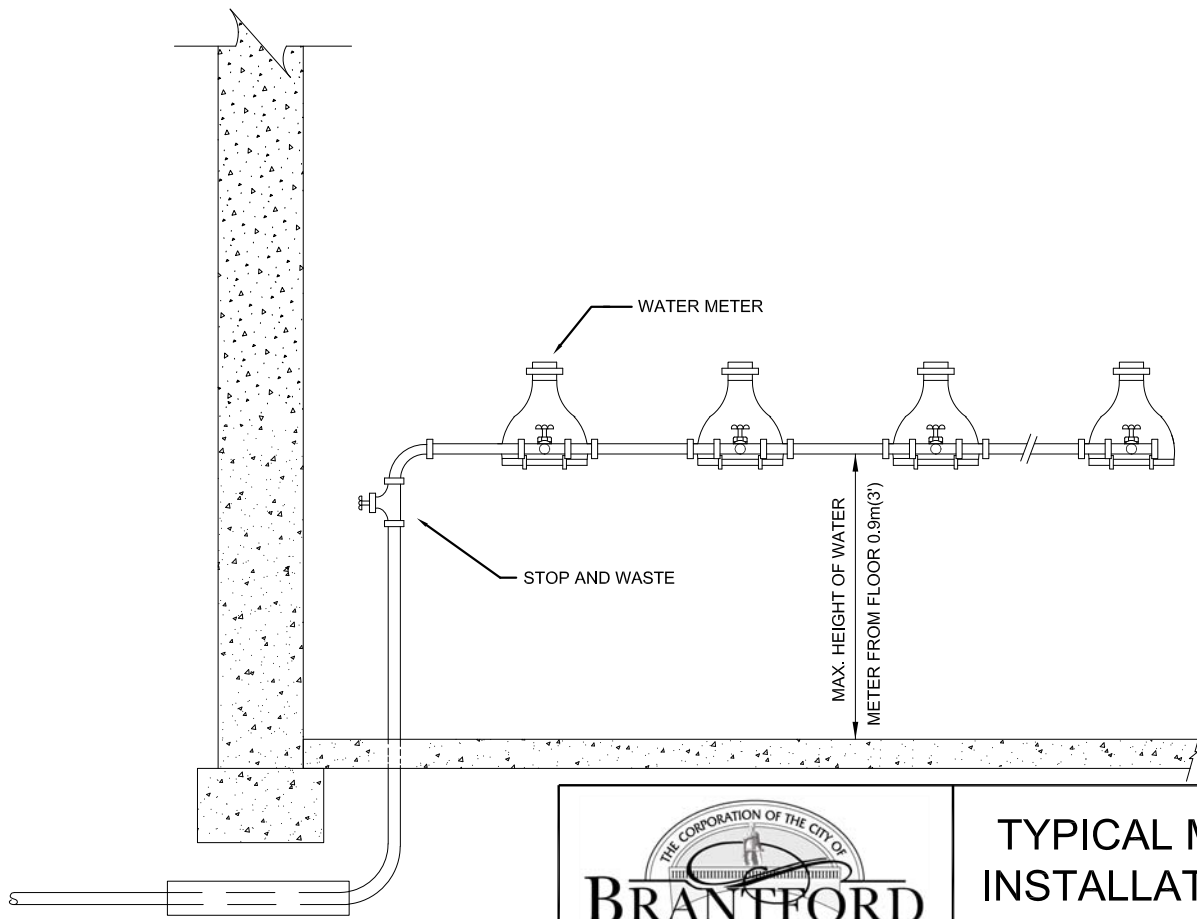
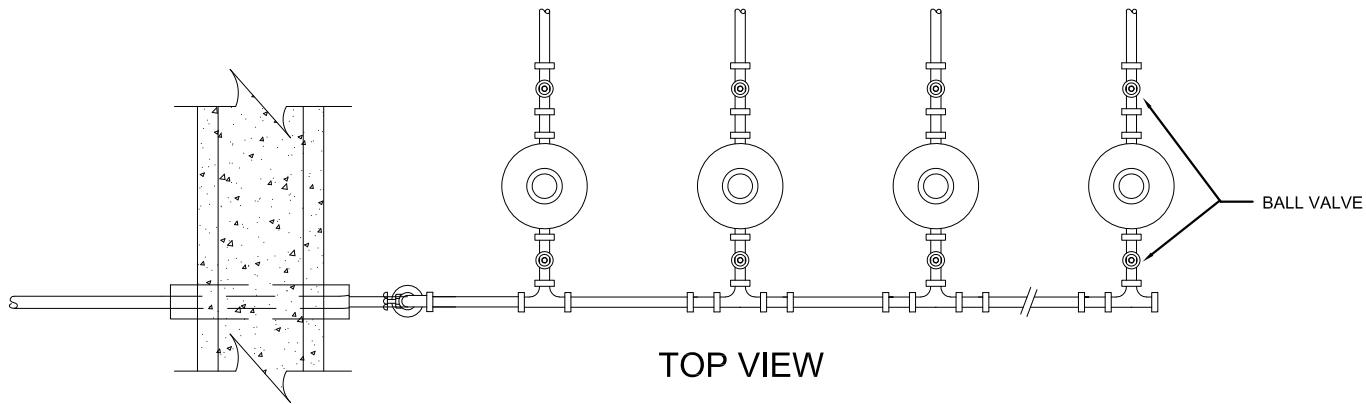

- NOTES:**
1. ALL METERS MUST HAVE A VALVE ON EACH SIDE.
  2. IF THE CITY OF BRANTFORD CONSIDERS IT NECESSARY, A BY-PASS SHALL BE INSTALLED (i.e., ESSENTIAL BUSINESS etc., RE: SHUT-DOWN).
  3. A CHECK VALVE MUST BE INSTALLED IF THE METER AND HOT WATER TANK ARE SEPARATED BY LESS THAN 1.83m (6') OF PIPE. IF P.E. COLD WATER PIPE IS USED.
  4. ALL STOP AND WASTES USED ON 19mm (3/4") OR 25mm (1") SERVICES MUST BE FLARED(NO SOLDER) OR CORPORATION STYLE COMPRESSION X F.I.P. TO ACCOMMODATE THE METER TAIL PIECE.
  5. 19mm(3/4") OR 25mm(1") 90° TAIL PIECES SUPPLIED BY CITY OF BRANTFORD.
  6. METERS SHALL NOT BE INSTALLED IN CRAWL SPACES, CLOSETS OR ANY OTHER CONFINED SPACES.
  7. NO SOLDERED JOINTS WILL BE ALLOWED BELOW THE STOP AND WASTE.
  8. METER TAIL PIECES MUST BE INSTALLED IN A MANNER THAT ALLOWS EASY REPLACEMENT WITHOUT SOLDERING.
  9. METERS MUST BE SUPPORTED USING A SUPPORT UNLESS OTHERWISE APPROVED BY THE ENGINEER.
  10. IMMEDIATELY AFTER THE WATER SERVICE PASSES UNDER THE FOOTING. IT HAS TO BE BROUGHT UP THROUGH THE FLOOR AND BE METERED AT THAT POINT.
  11. NO COUPLINGS WILL BE ALLOWED ON THE COPPER WATER SERVICE UNDER THE FOOTING OR FLOOR OR BETWEEN THE OUTSIDE WALL AND THE METER.
  12. ALL MATERIALS MUST CONFORM TO THE CURRENT ONTARIO BUILDING CODE, PART 7.



## TYPICAL MULTIPLE METER INSTALLATION C/W HEADER MAIN

ENGINEERING SERVICES DEPARTMENT	
DATE: DEC. 2004	N.T.S.
REV: NOV. 2021	
<b>W-116</b>	DRAWN BY: J. RATANAVANH



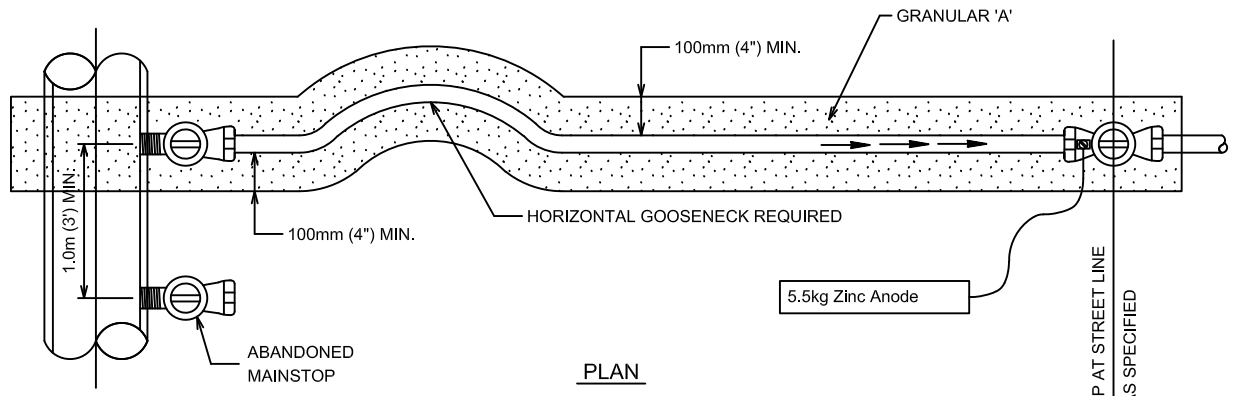

PLAN

NOTES:

1. ANY JUNCTION MADE IN SERVICE PIPE BETWEEN CORPORATION MAINSTOP AND CURBSTOP IS TO BE MADE BETWEEN THE CURBLINE AND STREET LINE WITH A CORPORATION COUPLING.
2. ALL WATER SERVICES TO BE INSTALLED AT RIGHT ANGLES TO THE WATERMAIN UNLESS APPROVED OTHERWISE.

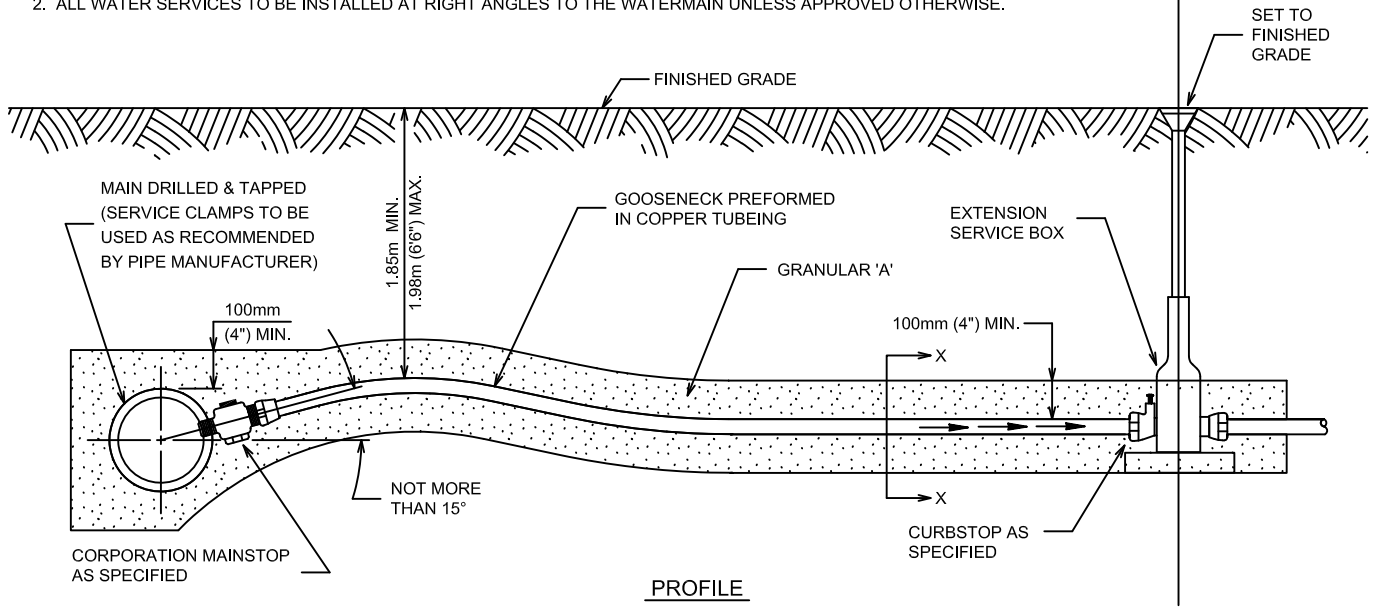

PROFILE

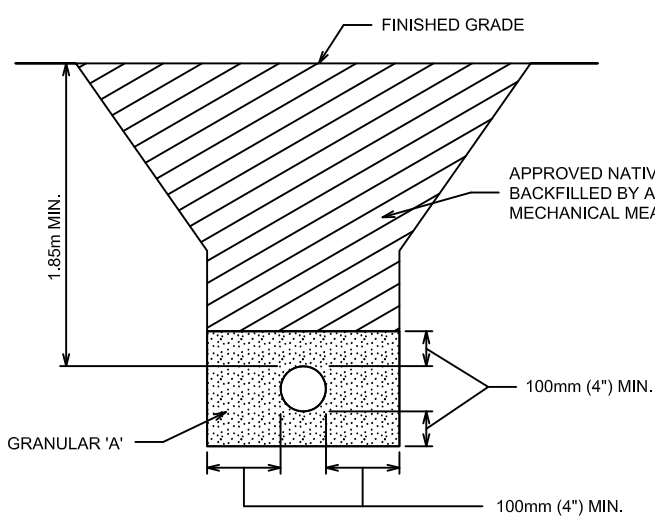

CROSS SECTION "X-X"

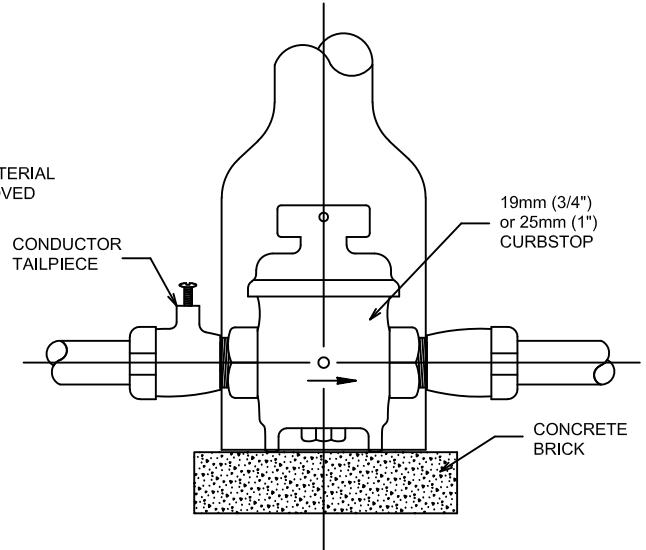

CURBSTOP



**STANDARD WATER CONNECTION  
DETAILS FOR 19mm (3/4") AND 25mm  
(1") SERVICES AND SERVICE  
BEDDING FOR CORROSIVE SOIL**

ENGINEERING SERVICES  
DEPARTMENT

REV: FEB. 1987	N.T.S.
DATE: NOV. 2021	DRAWN BY: A. SCHOEN
<b>W-201</b>	

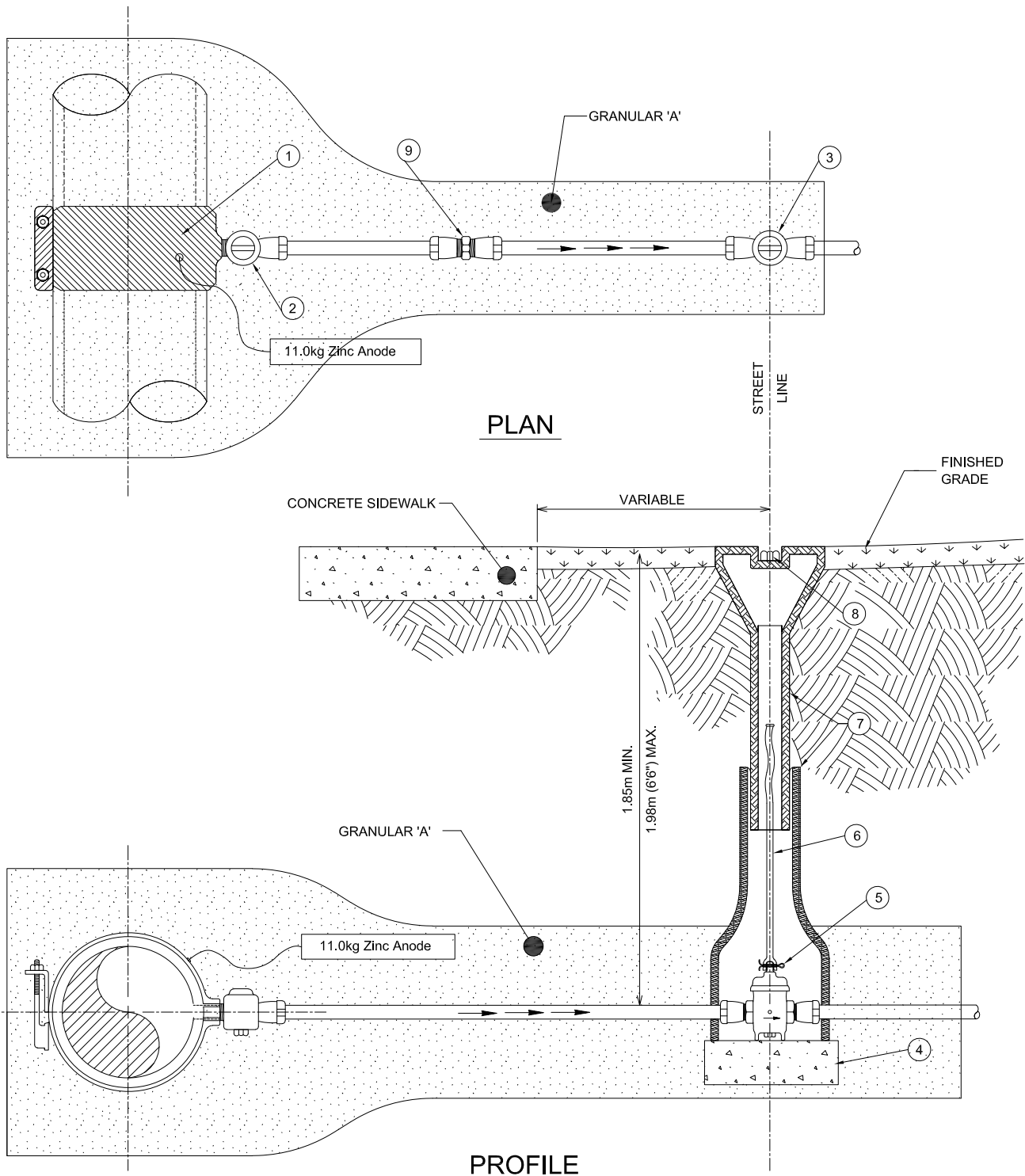

- 1. DOUBLE BOLT SADDLE
- 2. MAINSTOP
- 3. CURBSTOP
- 4. CONCRETE BLOCK
- 5. PIN (STAINLESS STEEL)

- 6. STAINLESS STEEL ROD
- 7. EXTENSION BARREL - TWO PIECES
- 8. PLUG (BRONZE)
- 9. COUPLING - COPPER TO COPPER

NOTES: 1) ALL WATER SERVICES ARE TO BE INSTALLED AT RIGHT ANGLES TO THE WATERMAIN UNLESS OTHERWISE APPROVED.



## PIPING ARRANGEMENT FOR 38mm & 50mm WATER SERVICES

ENGINEERING SERVICES  
DEPARTMENT

DATE: JULY 1985

REV: NOV. 2021

N.T.S.

W-202

DRAWN BY:  
A. SCHOEN

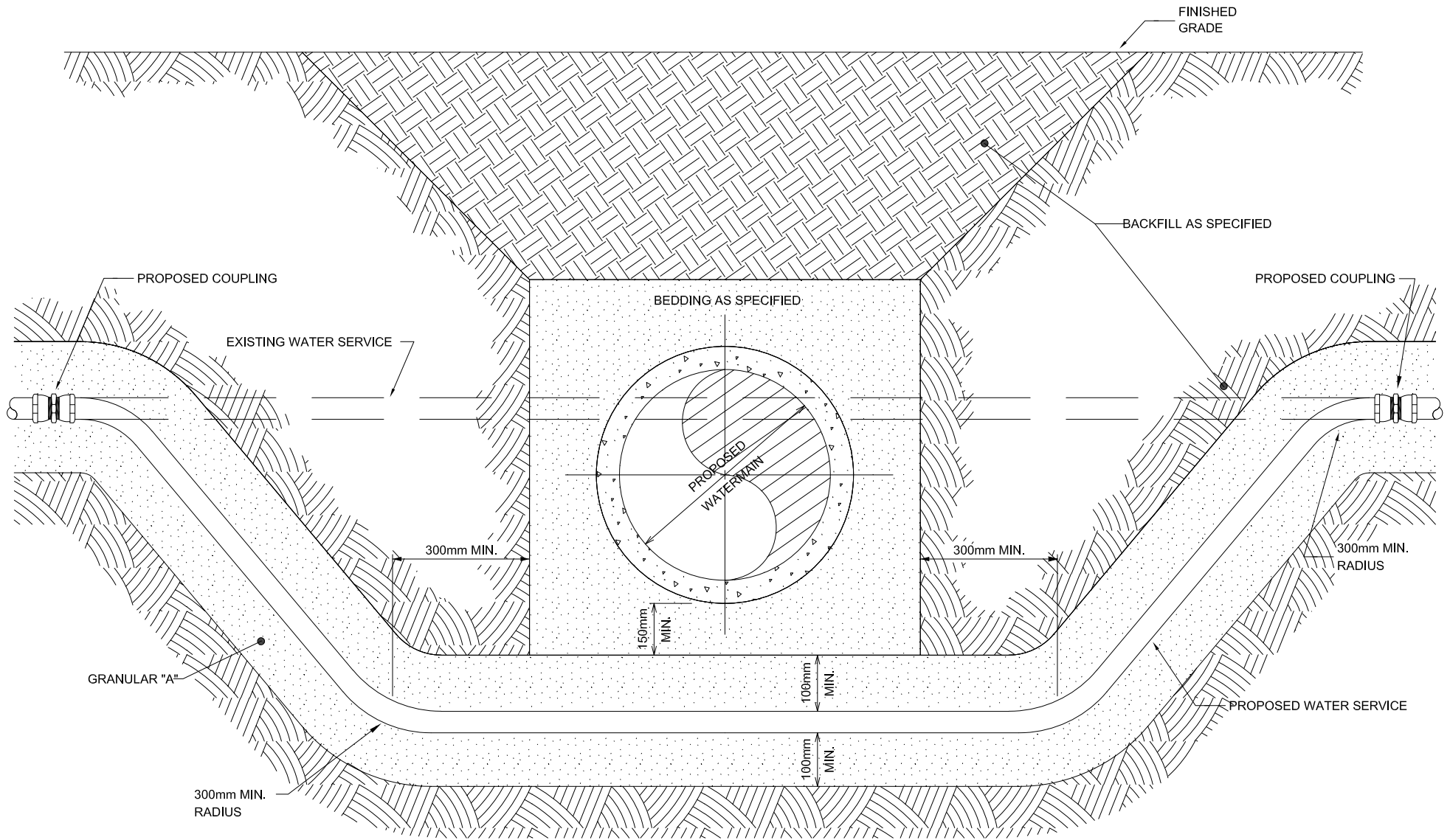

# WATERMAIN SERVICING LOWERING DETAIL

ENGINEERING SERVICES DEPARTMENT	
DATE: FEB.1985	N.T.S.
REV: NOV. 2021	
<b>W-203</b>	DRAWN BY: A. SCHOEN

# LEGEND

## SYMBOLS



REDUCER



VALVE

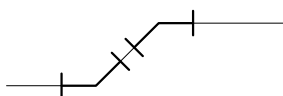

BENDS

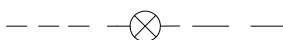

OBSOLETE WATER SERVICE



WATER SERVICE

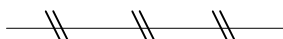

ABANDONED

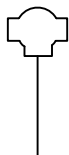

FIRE HYDRANT



BLOW-OFF



ANODE



TEST BOX



## LEGEND

ENGINEERING SERVICES  
DEPARTMENT

DATE: FEB. 1987

N.T.S.

REV: NOV. 2021

W-301

DRAWN BY:  
A. SCHOEN

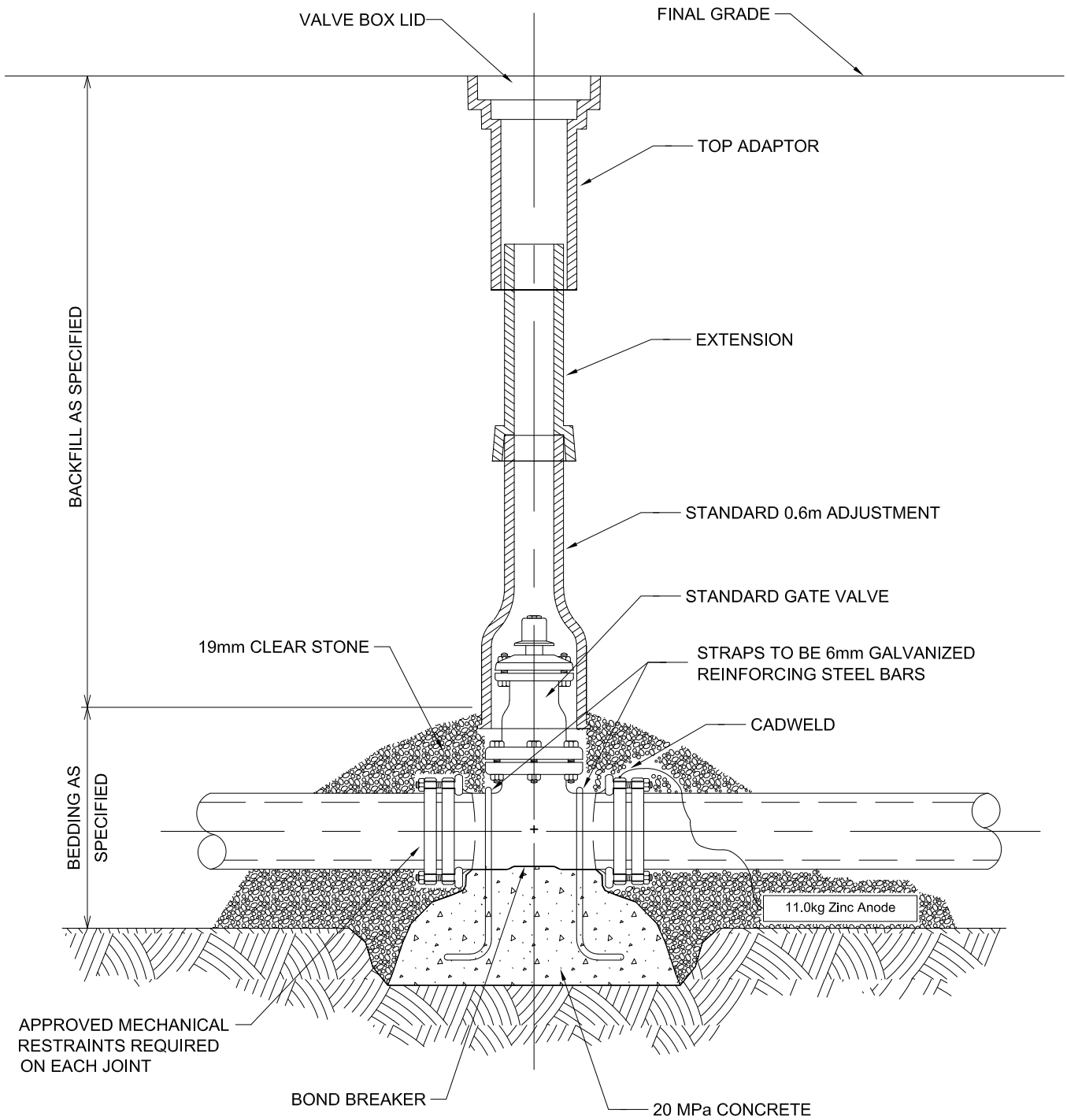

**NOTES:**

1. VALVE BOX TO BE ADEQUATELY BRACED WHILE BACKFILLING AND MUST REMAIN PLUMB.
2. VALVE BOX EXTENSION TO BE USED ONLY IF REQUIRED.
3. BOND BREAKER TO BE USED BETWEEN CONCRETE AND VALVE.
4. ALL CONCRETE TO BE 20 MPa AT 28 DAYS.
5. MINIMUM COVER OVER REINFORCING STEEL TO BE 75mm.
6. CORROSION PROTECTION SHALL BE AFFIXED AS PER STANDARD SPECIFICATIONS FOR WATERMAIN CONSTRUCTION.



## VALVE & VALVE BOX INSTALLATION FOR 100mm TO 350mm WATERMAIN

ENGINEERING SERVICES  
DEPARTMENT

DATE: DEC. 2006

REV: NOV. 2021

**W-303**

N.T.S.

DRAWN BY:  
A. SCHOEN

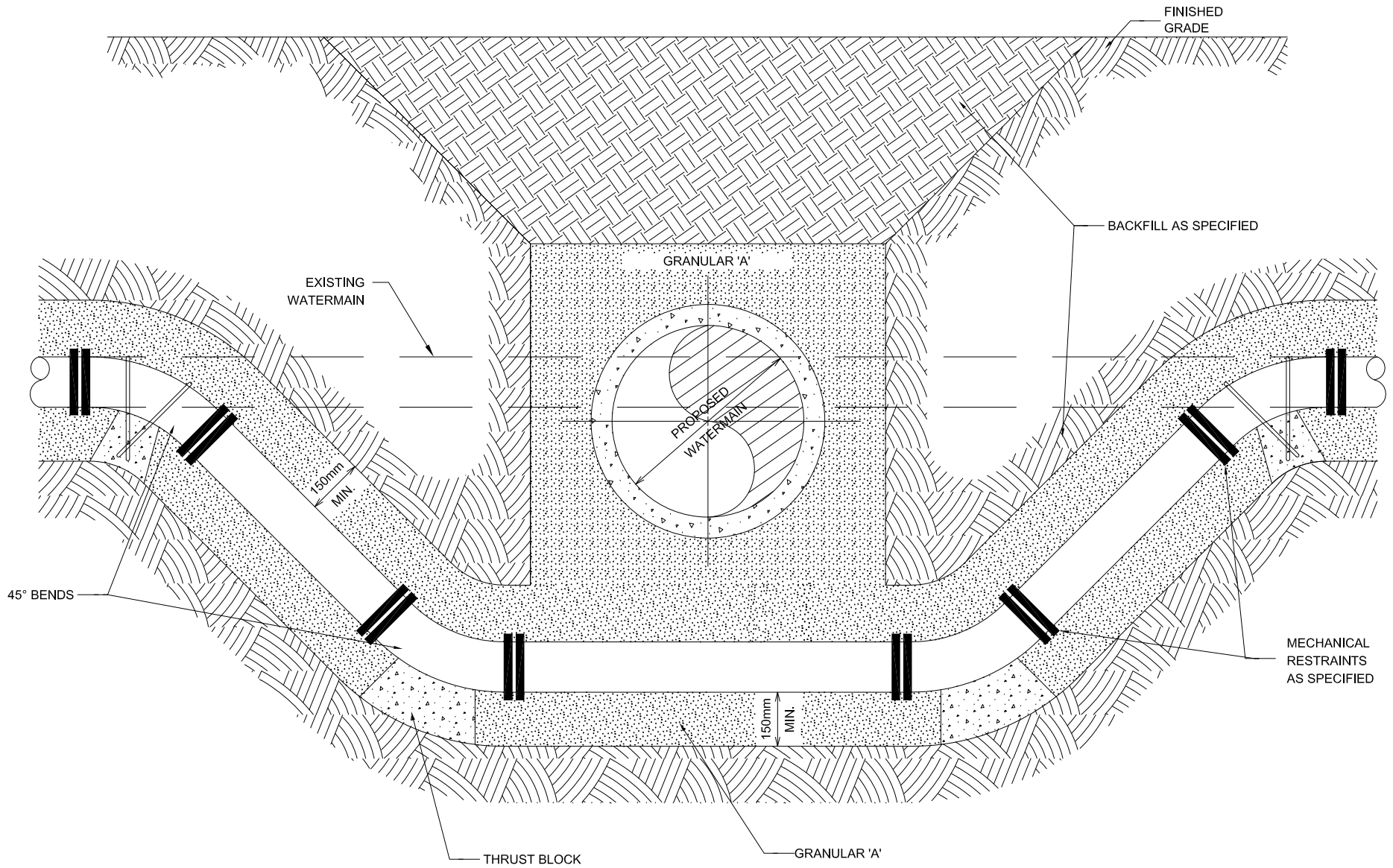

**NOTE:**  
 RESTRAINTS MUST BE USED ON ALL BENDS.

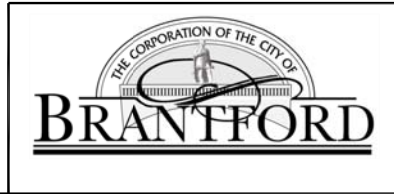

## WATERMAIN LOCATION DETAIL

ENGINEERING SERVICES DEPARTMENT	
DATE: FEB.1985	N.T.S.
REV: NOV. 2021	DRAWN BY: A. SCHOEN
<b>W-304</b>	

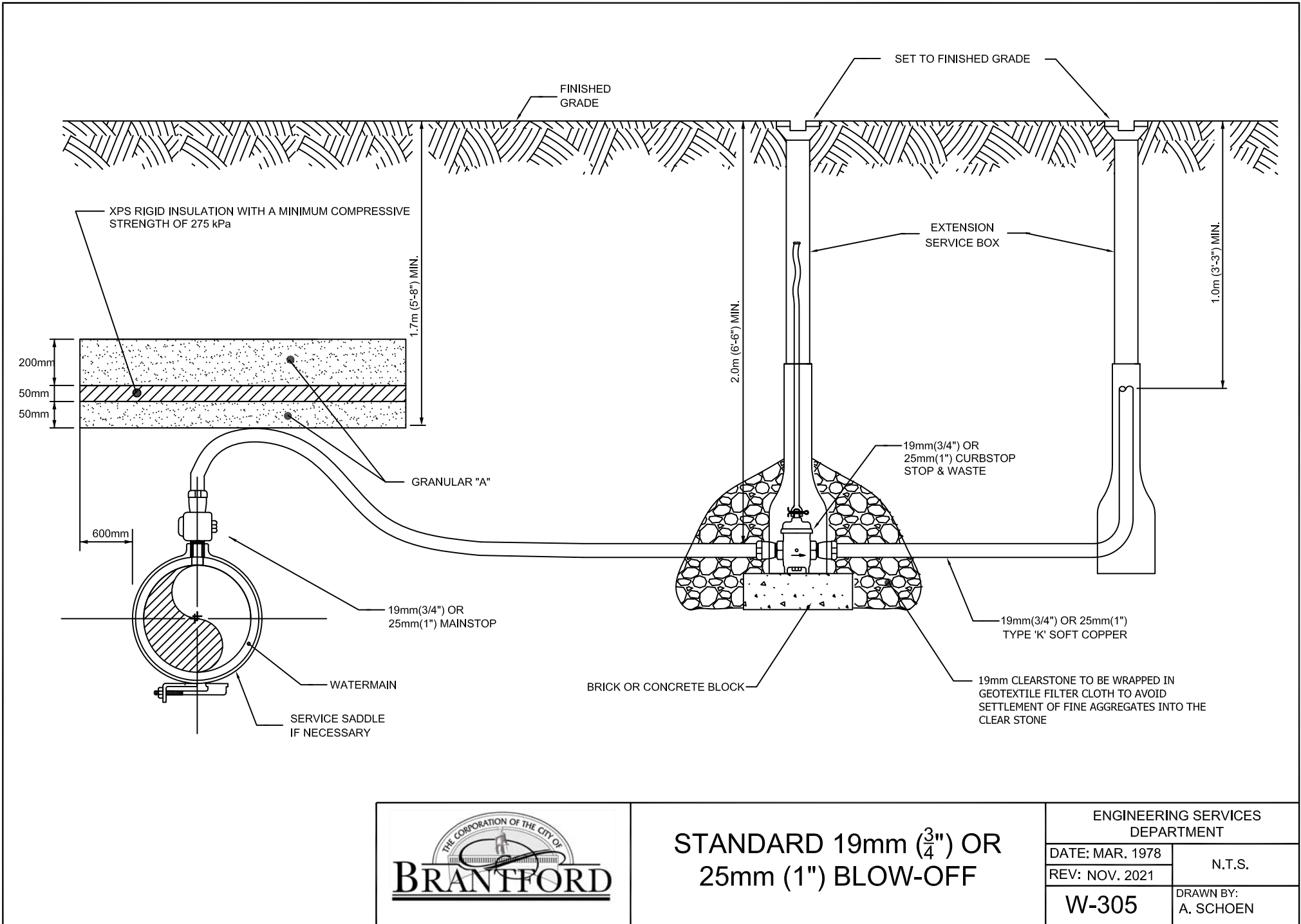

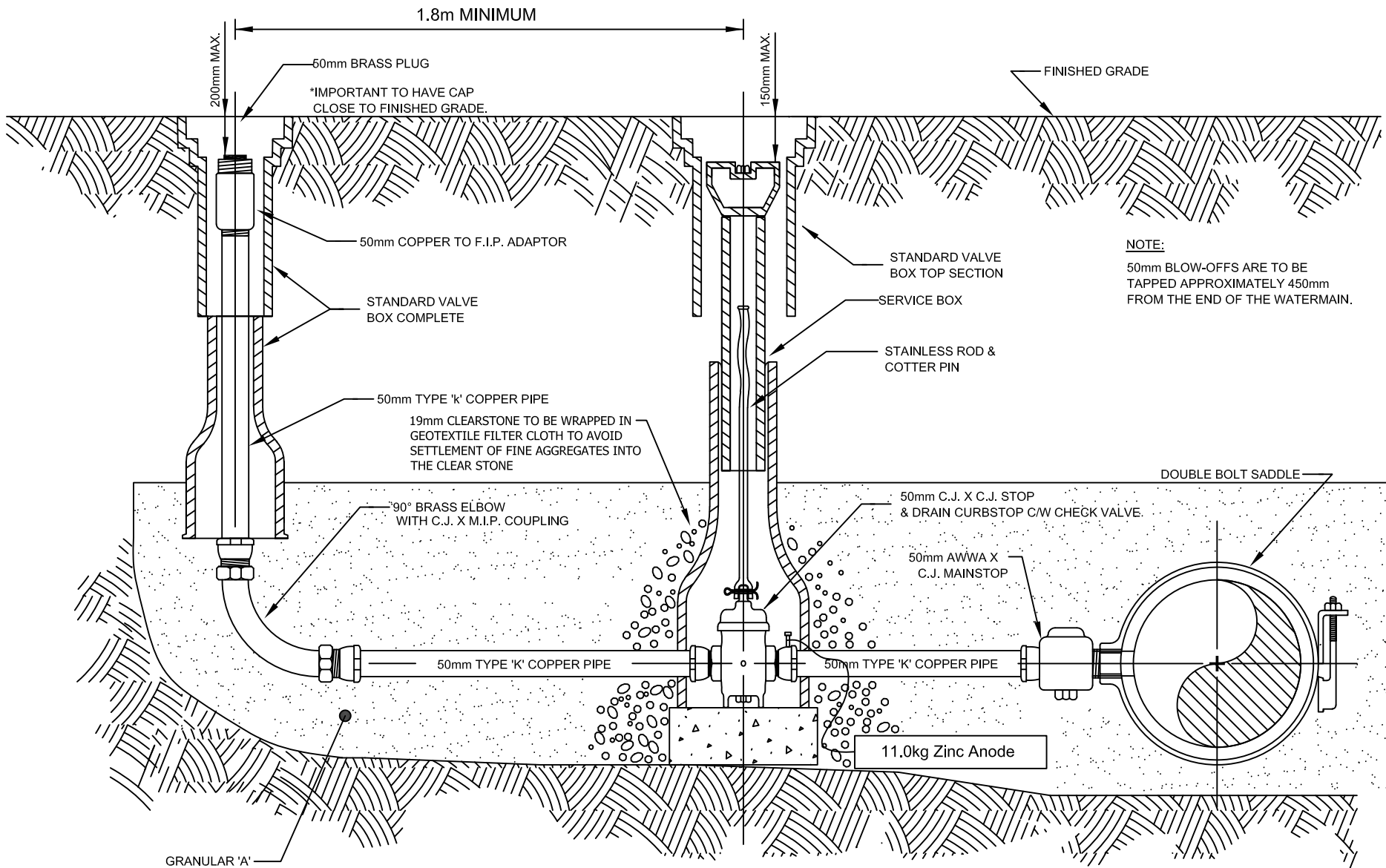

## STANDARD 50mm (2") COPPER BLOW-OFF INSTALLATION

ENGINEERING SERVICES  
DEPARTMENT

DATE: AUG. 1987

REV: NOV. 2021

W-306

N.T.S.

DRAWN BY:  
J. RATANAVANH



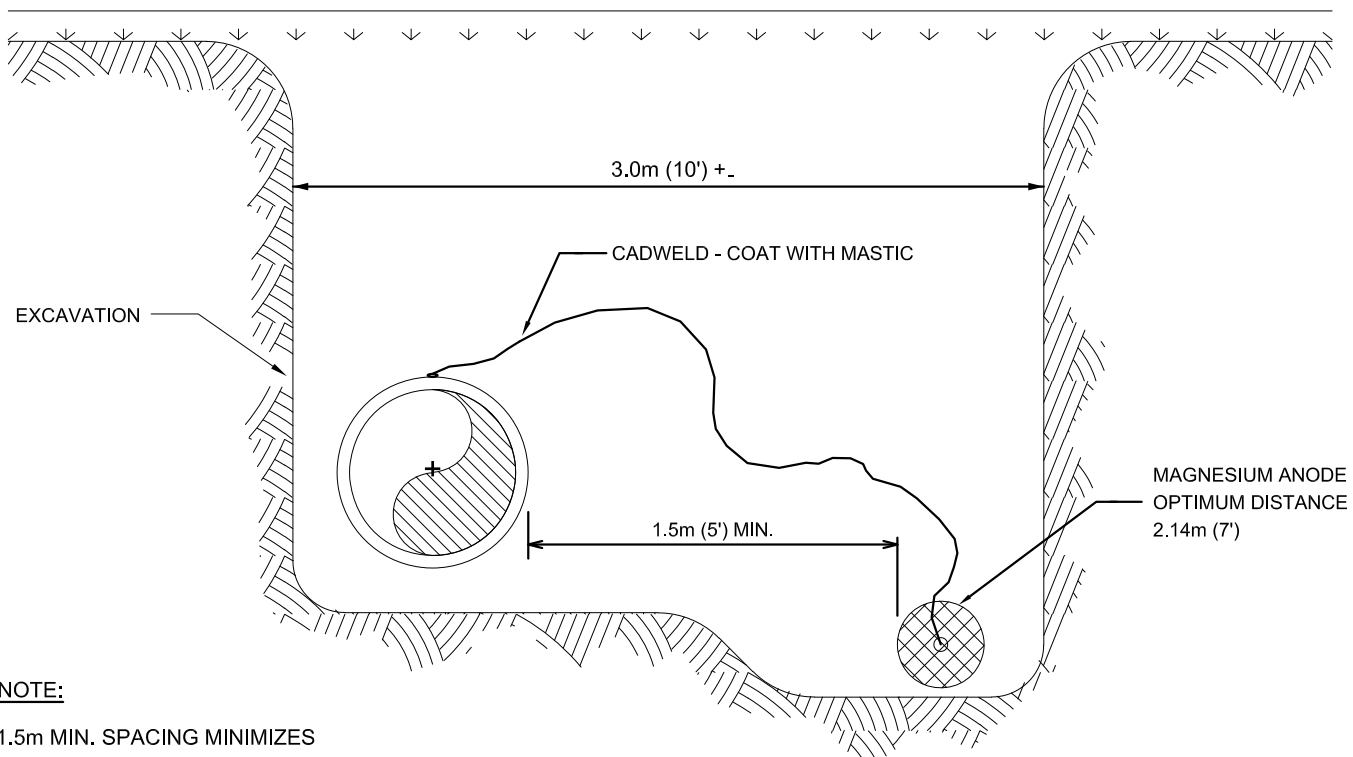

### MAGNESIUM ANODE INSTALLATION

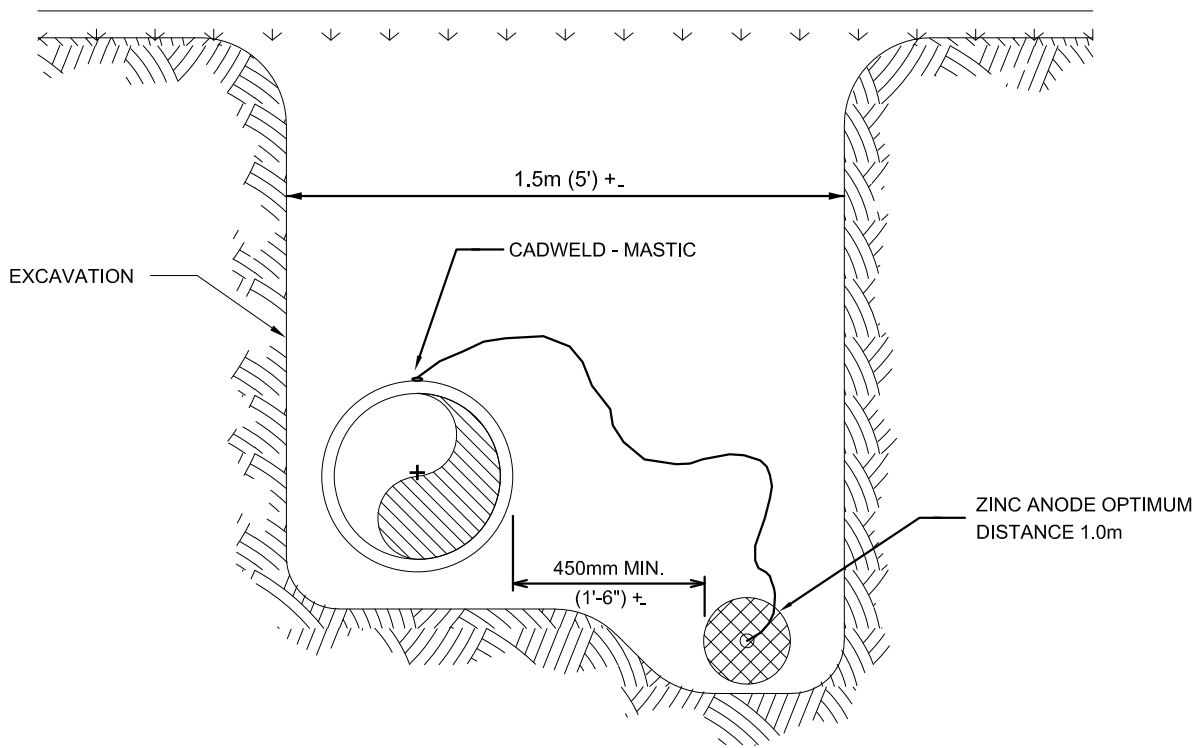

### ZINC ANODE INSTALLATION



## ANODE INSTALLATION

ENGINEERING SERVICES  
DEPARTMENT

DATE: APRIL 1986

REV: NOV. 2021

**W-307**

N.T.S.

DRAWN BY:  
A. SCHOEN

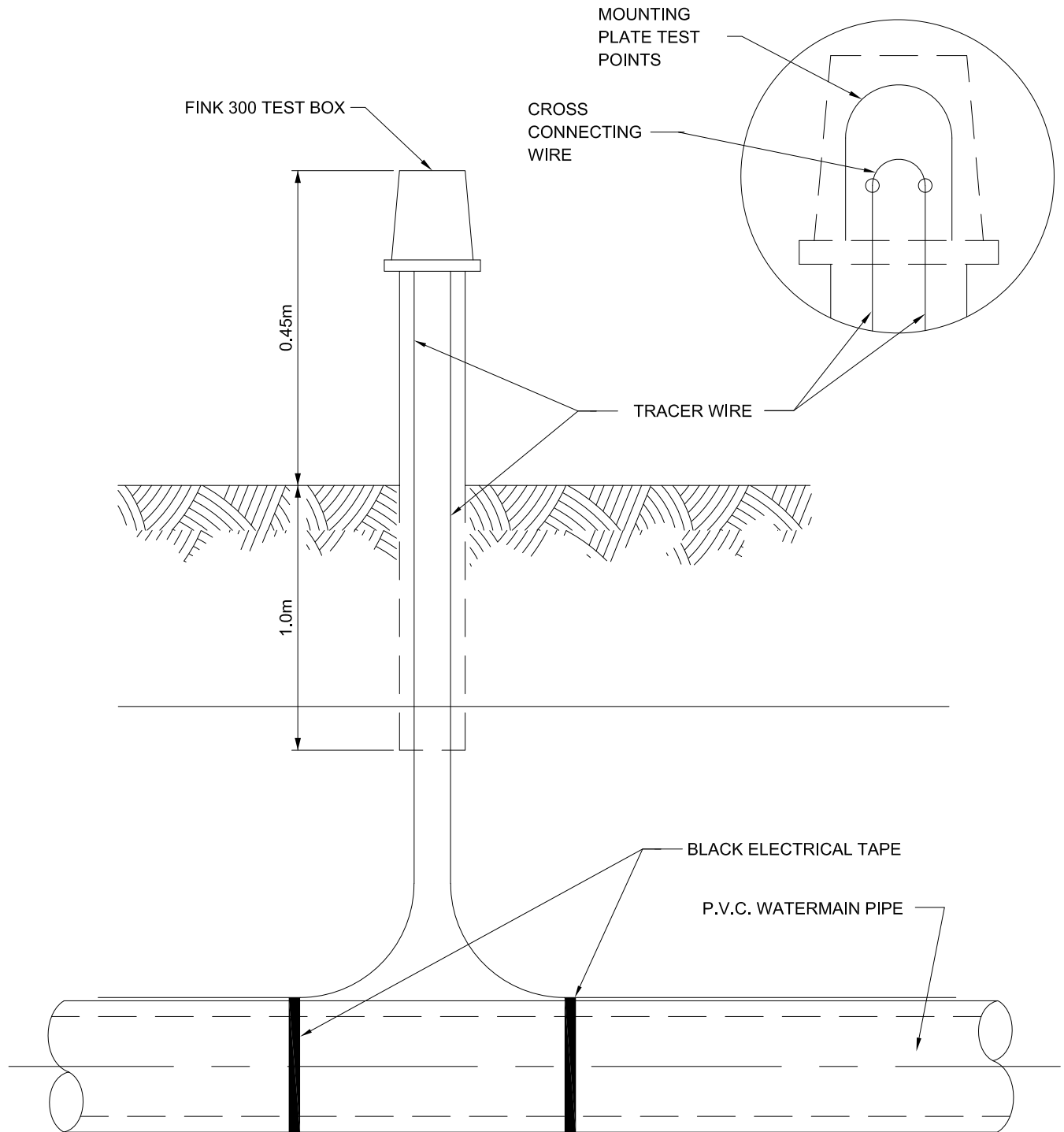

**NOTES:**

1. THIS TEST BOX IS INSTALLED BEHIND EVERY HYDRANT IN ANY NEW DEVELOPMENT USING P.V.C. WATERMAIN PIPE. OTHER LOCATIONS MAY BE ACCEPTABLE IF APPROVED BY THE CITY OF BRANTFORD WATER ENGINEERING DEPARTMENT.
2. THE CAP ON THE TEST BOX IS TO BE COLOUR CODED WATERWORKS BLUE.



**TEST BOX INSTALLATION AND  
TRACER WIRE ON P.V.C.  
WATERMAIN PIPE INSTALLATION**

ENGINEERING SERVICES  
DEPARTMENT

DATE: DEC. 1989

REV: NOV. 2021

N.T.S.

**W-308**

DRAWN BY:  
A. SCHOEN

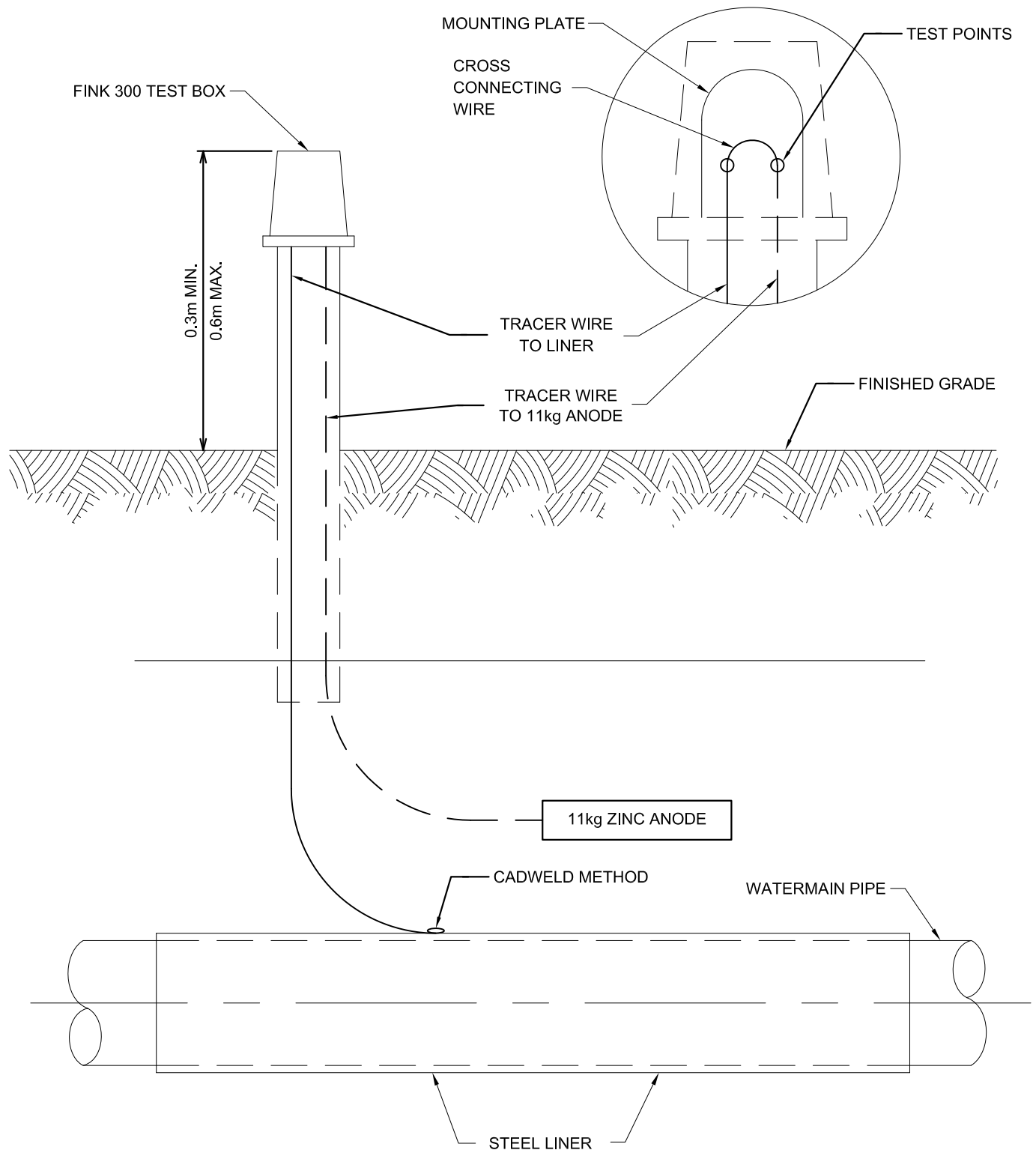

**NOTE:**

THE CAP ON THE TEST BOX IS TO BE COLOUR CODED WATERWORKS BLUE.



**TEST BOX AND TRACER WIRE  
INSTALLATION IN  
CONJUNCTION WITH A STEEL  
LINER**

ENGINEERING SERVICES  
DEPARTMENT

DATE: FEB. 1986

REV: NOV. 2021

N.T.S.

**W-308A**

DRAWN BY:  
A. SCHOEN

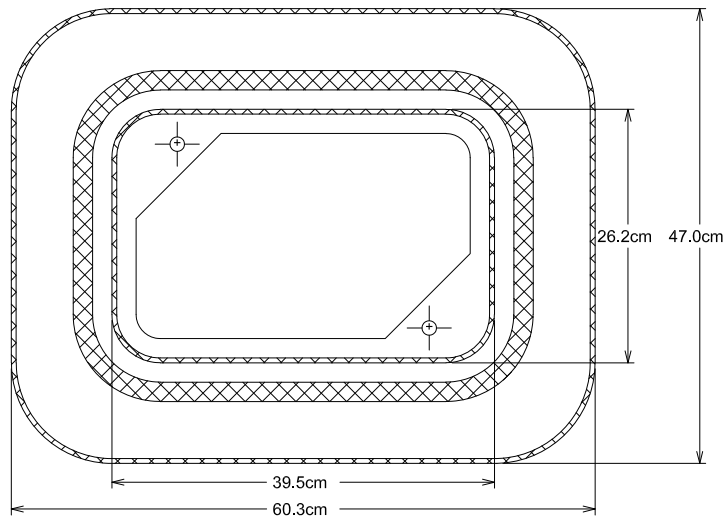

PLAN VIEW

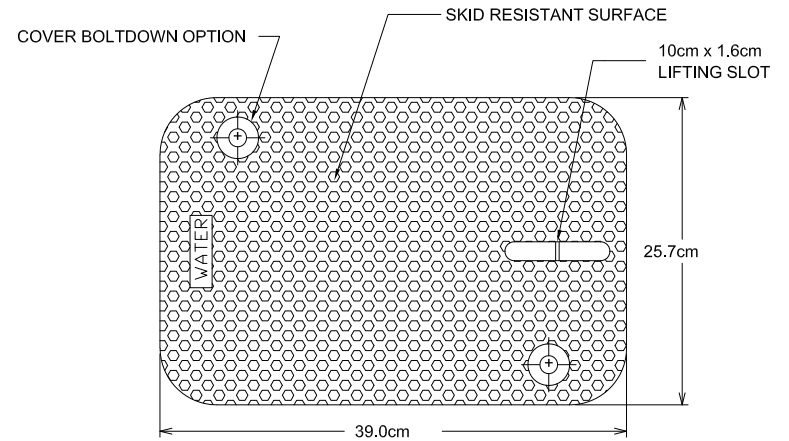

BOX COVER

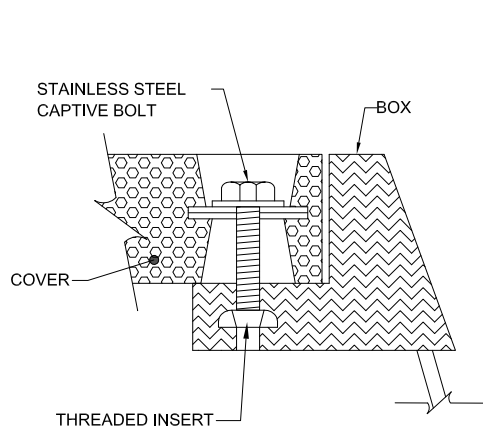

COVER BOLTDOWN OPTION

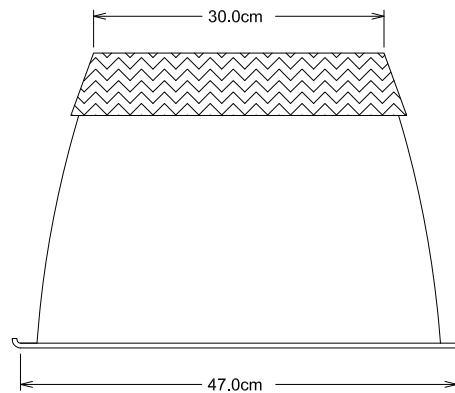

END VIEW

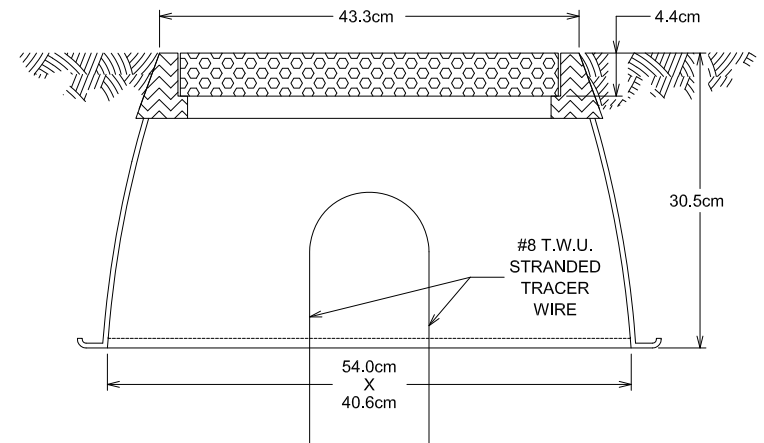

BOX & COVER SECTION

NOTE: THE COVER WILL BE COLOUR CODED GREY AND LABELLED 'WATER'.



**CDR 250mm x 380mm SERIES  
BOX & COVER TEST POINT**

ENGINEERING SERVICES  
DEPARTMENT

DATE: JAN. 1992

REV: NOV. 2021

**W-308B**

N.T.S.

DRAWN BY:  
A. SCHOEN

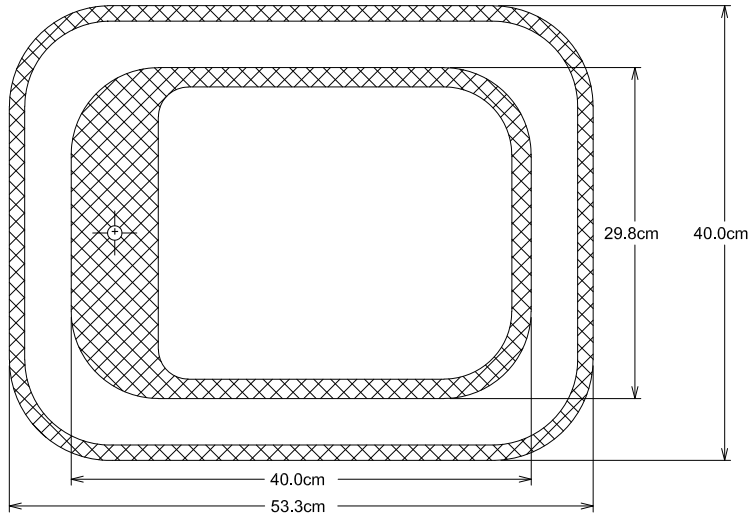

PLAN VIEW

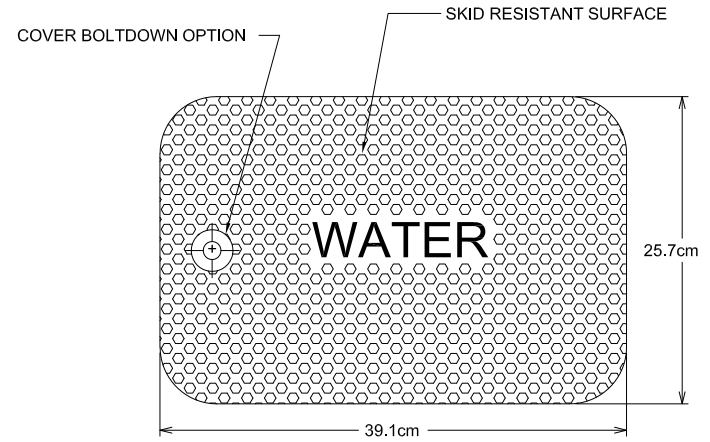

BOX COVER

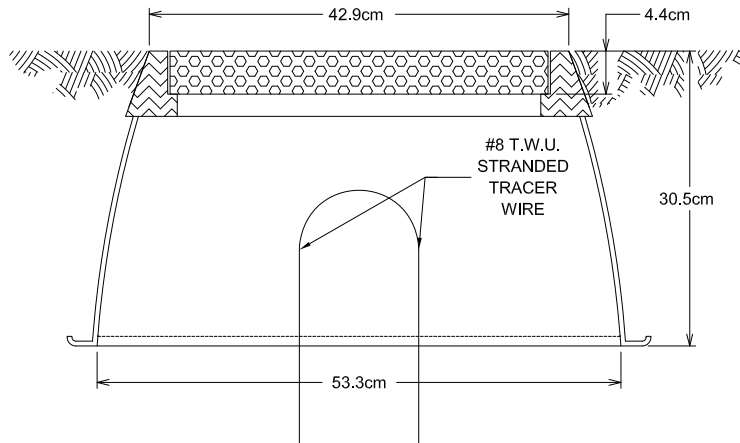

BOX & COVER SECTION

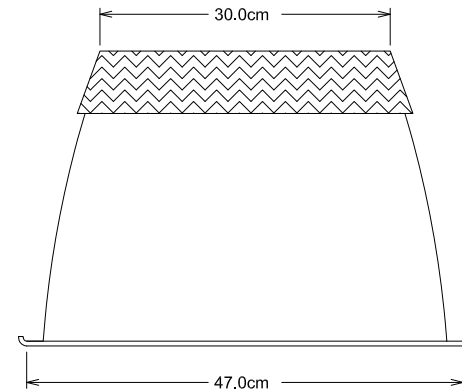

END VIEW

NOTE: THE COVER WILL BE COLOUR CODED GREY AND LABELLED 'WATER'.



**BOX & COVER TEST POINT  
UNDERGROUND CLOSURE**

ENGINEERING SERVICES  
DEPARTMENT

DATE: MAY 1993

REV: NOV. 2021

N.T.S.

**W-308C**

DRAWN BY:  
A. SCHOEN

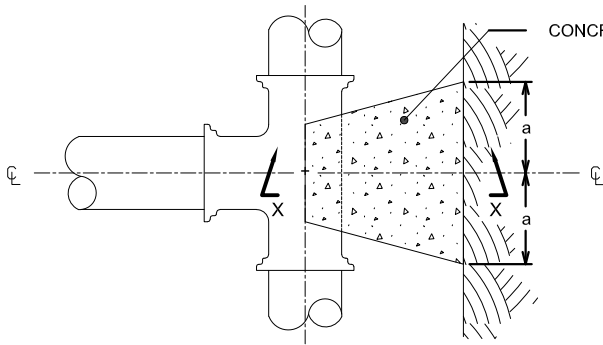

**PLAN - TEE**

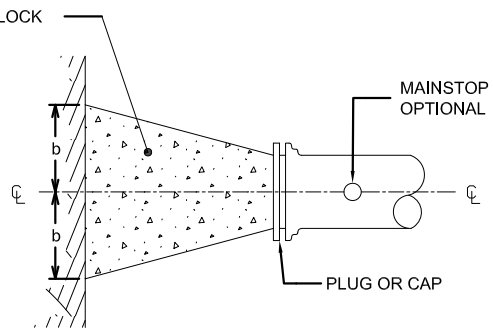

**PLAN - DEAD END**

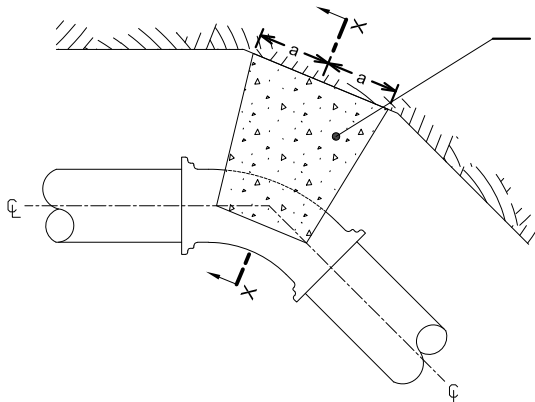

**PLAN - TYPICAL BEND**

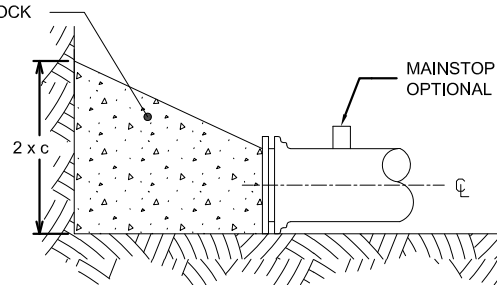

**ELEVATION - DEAD END**

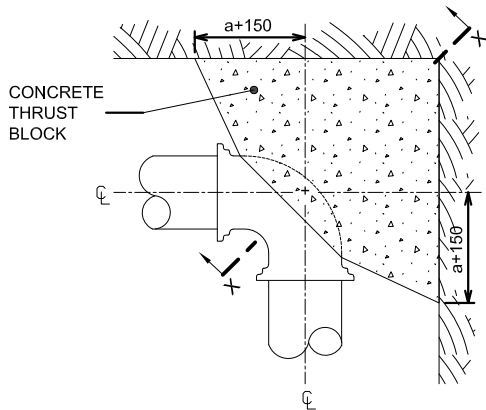

**PLAN - 90° BEND**

MINIMUM DIMENSIONS (mm)			
PIPE SIZE	a	b	c
100	150	150	150
150	250	250	200
200	250	300	200
250	350	400	250
300	450	450	300
350	500	550	400

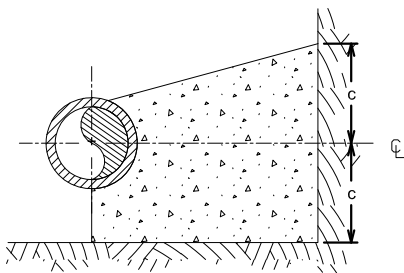

**CROSS SECTION X-X**

**NOTES:**

1. CONCRETE SHALL BE PLACED TO WITHIN 50mm OF THE FACE OF THE BELL.
2. POLYETHYLENE BOND BREAKER TO BE USED BETWEEN CONCRETE AND FITTINGS.
3. THIS BLOCKING DESIGN APPLIES ONLY WHERE 1035KPa PRESSURE IS NOT EXCEEDED.
4. THIS BLOCKING DESIGN APPLIES WHERE THE SOIL HAS A MINIMUM SOIL BEARING CAPACITY OF 200KPa.
5. ALL DIMENSIONS ARE IN MILLIMETERS OR METRES UNLESS OTHERWISE SHOWN.



**TYPICAL HORIZONTAL THRUST RESTRAINT**

ENGINEERING SERVICES DEPARTMENT

DATE: MAR. 1993

REV: NOV. 2021

N.T.S.

W-309

DRAWN BY:  
A. SCHOEN

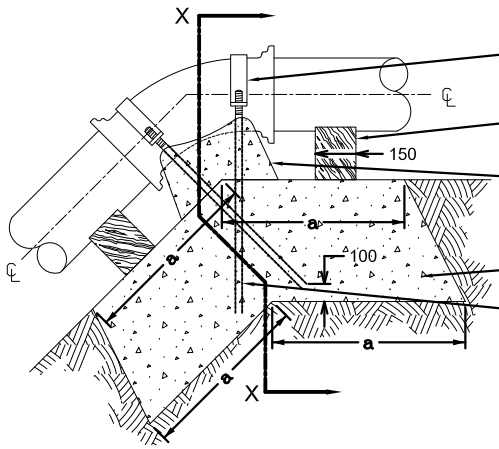

**UP-THRUST BLOCK  
ELEVATION**

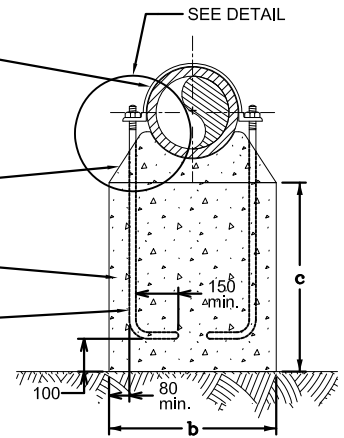

**UP-THRUST BLOCK  
SECTION X-X**

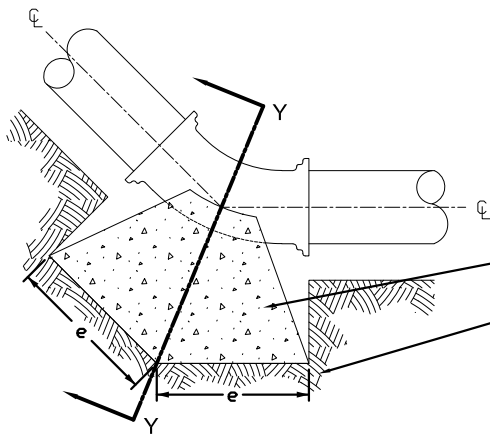

**DOWN-THRUST BLOCK  
ELEVATION**

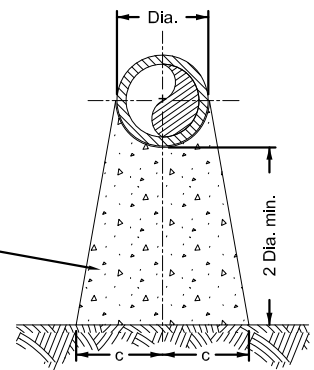

**DOWN-THRUST BLOCK  
SECTION Y-Y**

MINIMUM DIMENSIONS (mm)					
PIPE SIZE	a	b	c	d	e
100	450	600	750	13	150
150	500	900	900	13	300
200	600	900	1500	13	450
250	900	900	1500	20	600
300	1200	900	1650	20	800
350	1200	1200	1650	25	1000

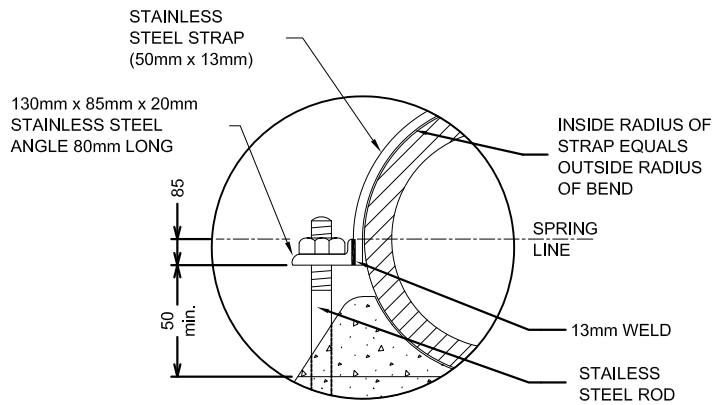

**STEEL STRAP DETAIL**

**NOTES:**

1. CONCRETE SHALL BE PLACED TO WITHIN 50mm OF THE FACE OF THE BELL.
2. POLYETHYLENE BOND BREAKER TO BE USED BETWEEN CONCRETE AND FITTINGS.
3. THIS BLOCKING DESIGN APPLIES ONLY WHERE 1035KPa PRESSURE IS NOT EXCEEDED.
4. THIS BLOCKING IS FOR BENDS UP TO 45° ONLY.
5. THIS BLOCKING DESIGN APPLIES WHERE THE SOIL HAS A MINIMUM SOIL BEARING CAPACITY OF 200KPa.
6. ALL DIMENSIONS ARE IN MILLIMETERS OR METRES UNLESS OTHERWISE SHOWN.



**TYPICAL VERTICAL  
THRUST RESTRAINT**

ENGINEERING SERVICES  
DEPARTMENT

DATE: MAR. 1993

N.T.S.

REV: NOV. 2021

**W-310**

DRAWN BY:  
A. SCHOEN

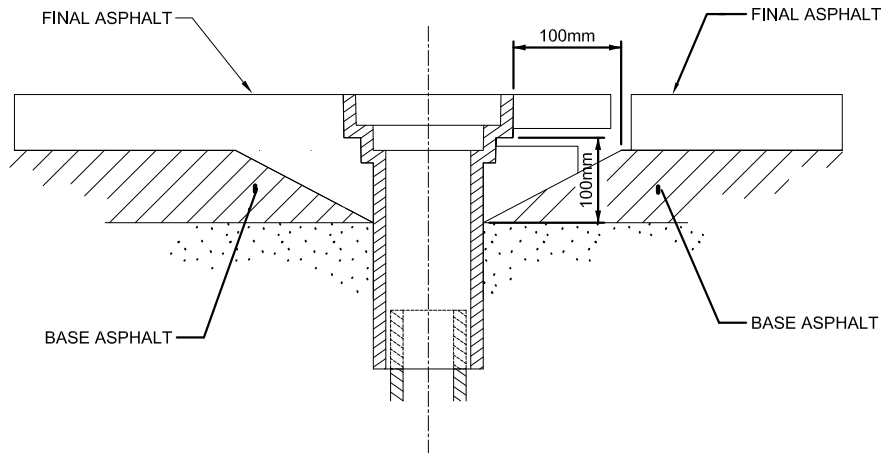
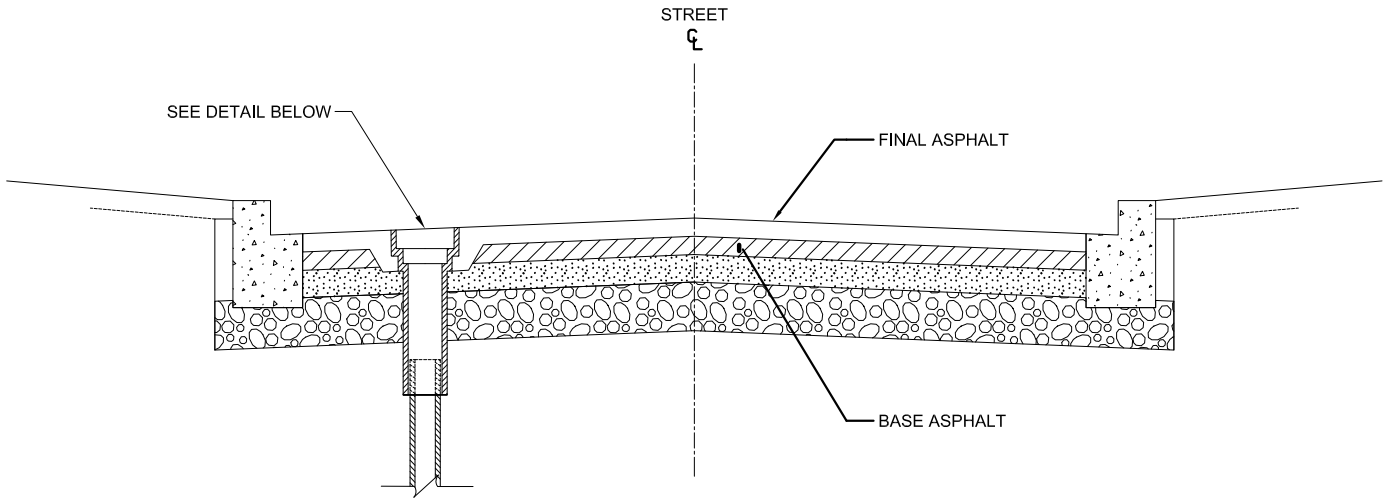

**TYPICAL INSTALLATION OF  
VALVE BOX ON NEWLY  
RECONSTRUCTED STREETS**

ENGINEERING SERVICES  
DEPARTMENT

DATE: AUG. 1987

N.T.S.

REV: NOV. 2021

**W-311**

DRAWN BY:  
A. SCHOEN



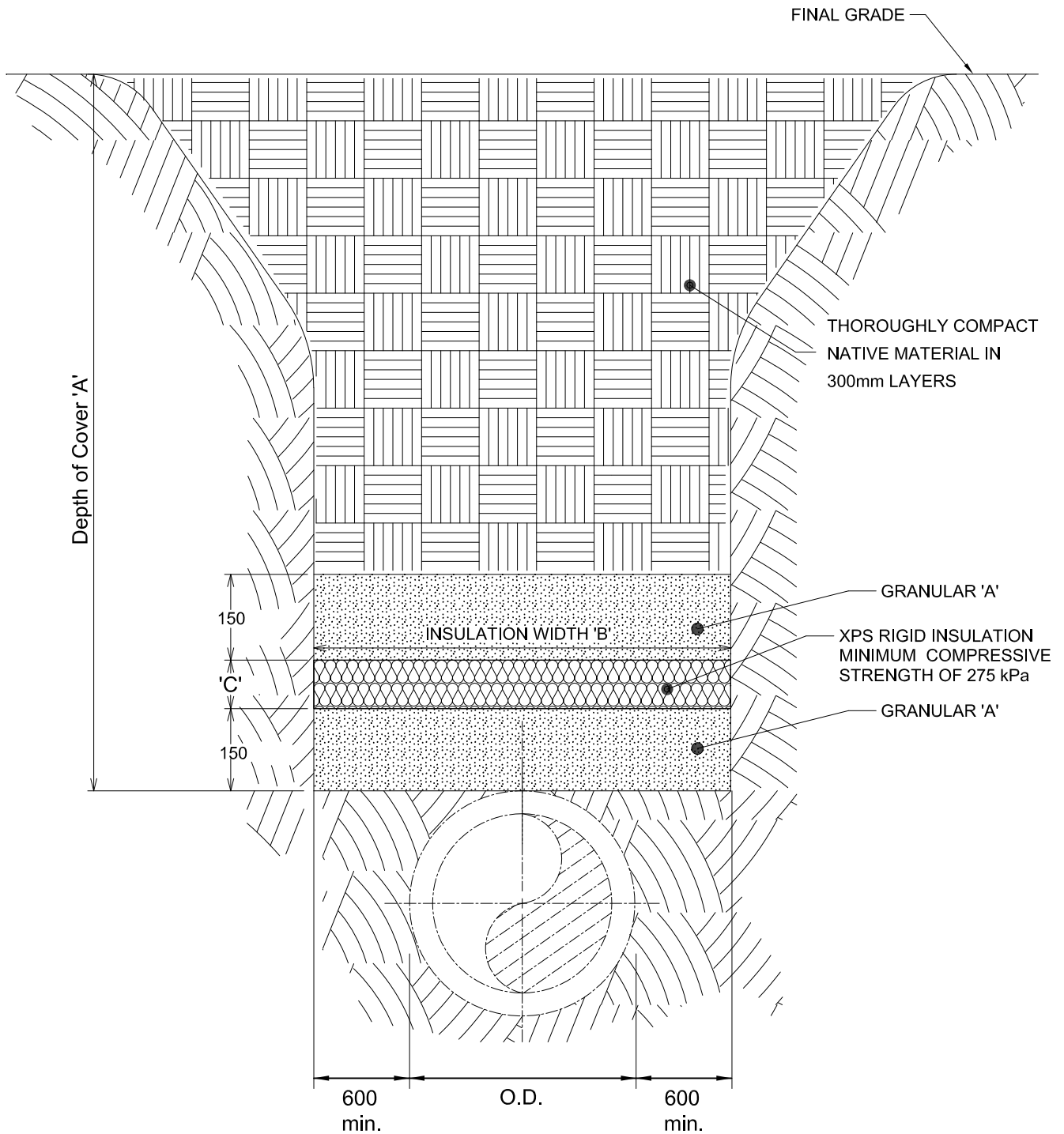

**NOTE:**

- 1) SELECTED NATIVE MATERIAL FOR BACKFILL OVER 150mm (6") GRANULAR 'A' LAYER.
- 2) ALL JOINTS TO BE STAGGERED FOR MULTIPLE INSULATION SHEETS.
- 3) ALL JOINTS TO BE TAPED.
- 4) ALL DIMENSIONS IN MILLIMETERS UNLESS OTHERWISE NOTED.

DEPTH OF COVER (m) 'A'	WIDTH OF INSULATION (m) 'B'	THICKNESS OF INSULATION (mm) 'C'
<1.50	1.20 + O.D.	50
<1.20	1.20 + O.D.	50
<1.05	1.20 + O.D.	100
<0.90	1.50 OR 1.20 + O.D.*	100

\* Use greater value



**INSULATION OF SEWERS AND WATERMANS IN SHALLOW TRENCHES "FROST BARRIER"**

ENGINEERING SERVICES DEPARTMENT

DATE: JAN. 1989

REV: JAN. 2023

N.T.S.

**W-312**

DRAWN BY:  
A. SCHOEN

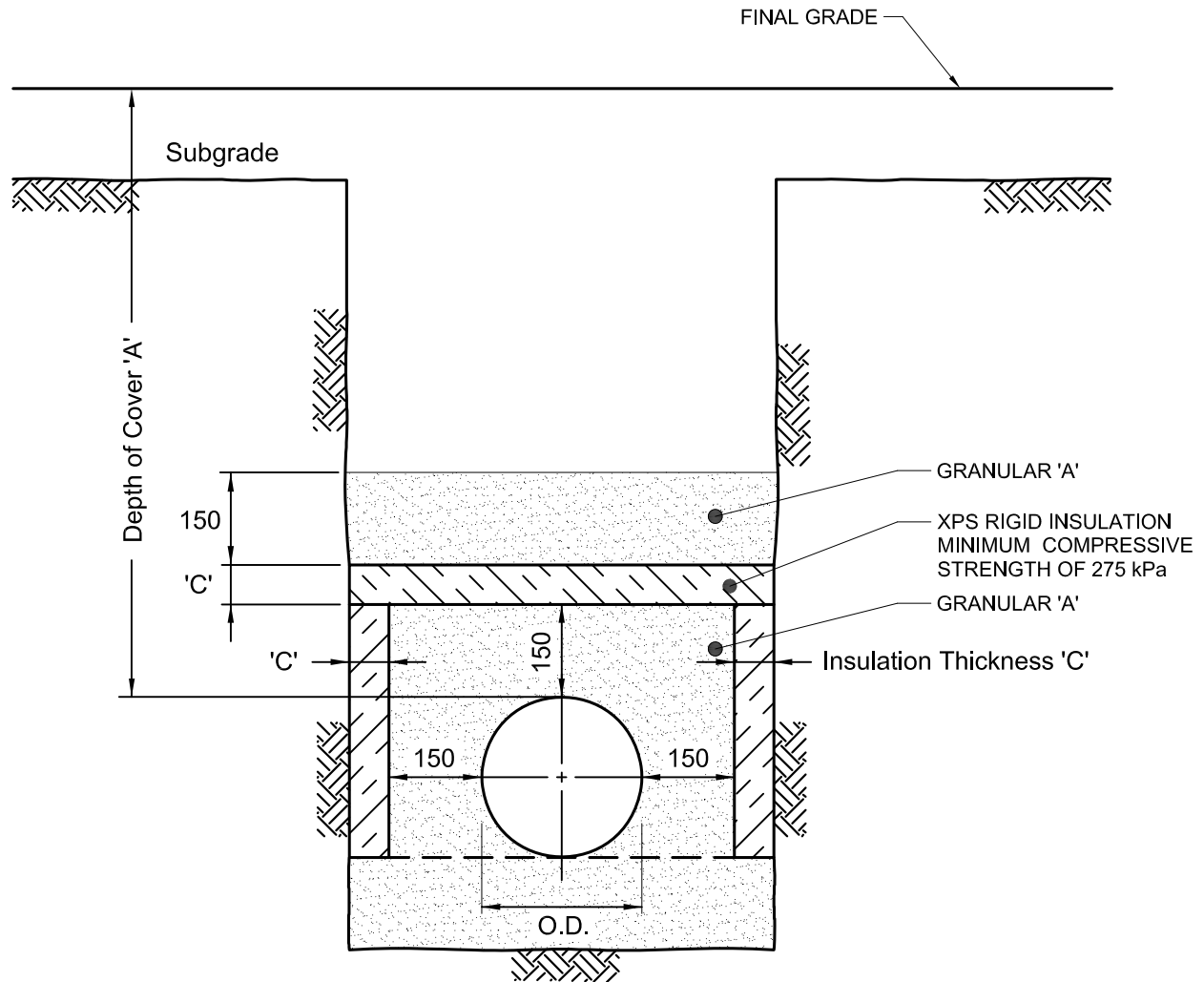

**NOTE:**

- 1) SELECTED NATIVE MATERIAL FOR BACKFILL OVER 150mm (6") GRANULAR 'A' LAYER.
- 2) ALL JOINTS TO BE STAGGERED FOR MULTIPLE INSULATION SHEETS.
- 3) ALL JOINTS TO BE TAPED.
- 4) ALL DIMENSIONS IN MILLIMETERS UNLESS OTHERWISE NOTED.

DEPTH OF COVER (m) 'A'	THICKNESS OF INSULATION (mm) 'C'
<1.50	50
<1.20	50
<1.05	100
<0.90	100



## INSULATION OF SEWERS AND WATERMANS IN SHALLOW TRENCHES "FROST BOX"

ENGINEERING SERVICES  
DEPARTMENT

DATE: DEC. 2021

REV: JAN. 2023

**W-312A**

N.T.S.

DRAWN BY:  
E. KERR

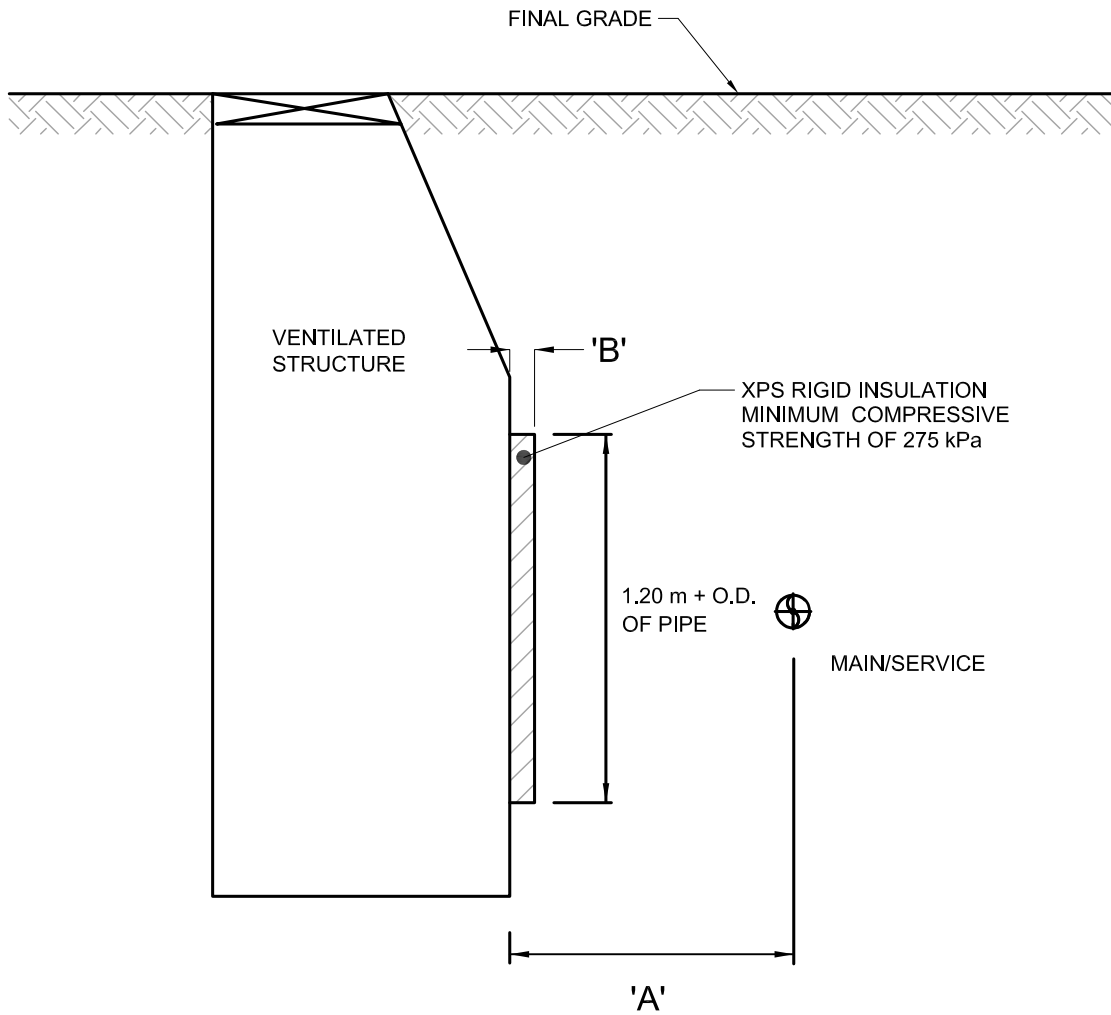

**NOTE:**

- 1) ALL JOINTS TO BE STAGGERED FOR MULTIPLE INSULATION SHEETS.
- 2) ALL JOINTS TO BE TAPED.
- 3) ALL DIMENSIONS IN MILLIMETERS UNLESS OTHERWISE NOTED.

HORIZONTAL DISTANCE (m) 'A'	THICKNESS OF INSULATION (mm) 'B'
<1.50	50
<1.20	50
<1.05	100
<0.90	100



**INSULATION OF SEWERS,  
WATERMAINS AND SERVICE  
CONNECTIONS ADJACENT TO  
VENTILATED STRUCTURES**

ENGINEERING SERVICES  
DEPARTMENT

DATE: DEC. 2021

REV: JAN. 2023

N.T.S.

**W-312B**

DRAWN BY:  
E. KERR

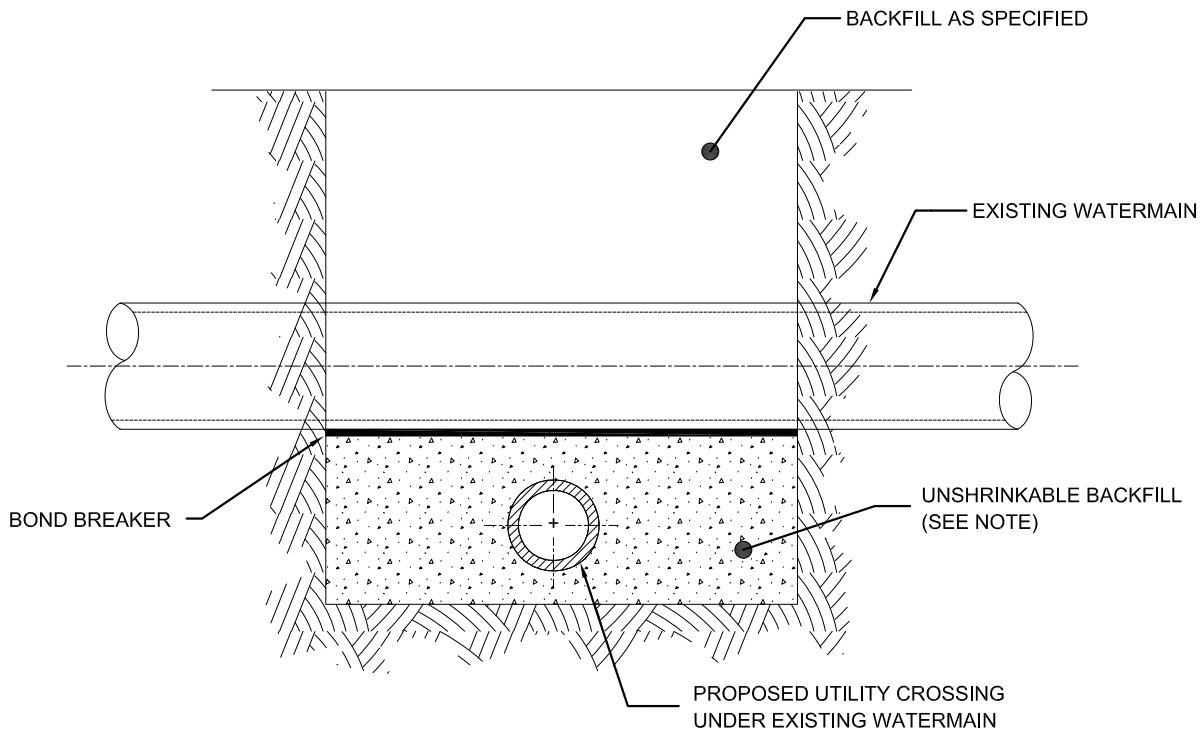
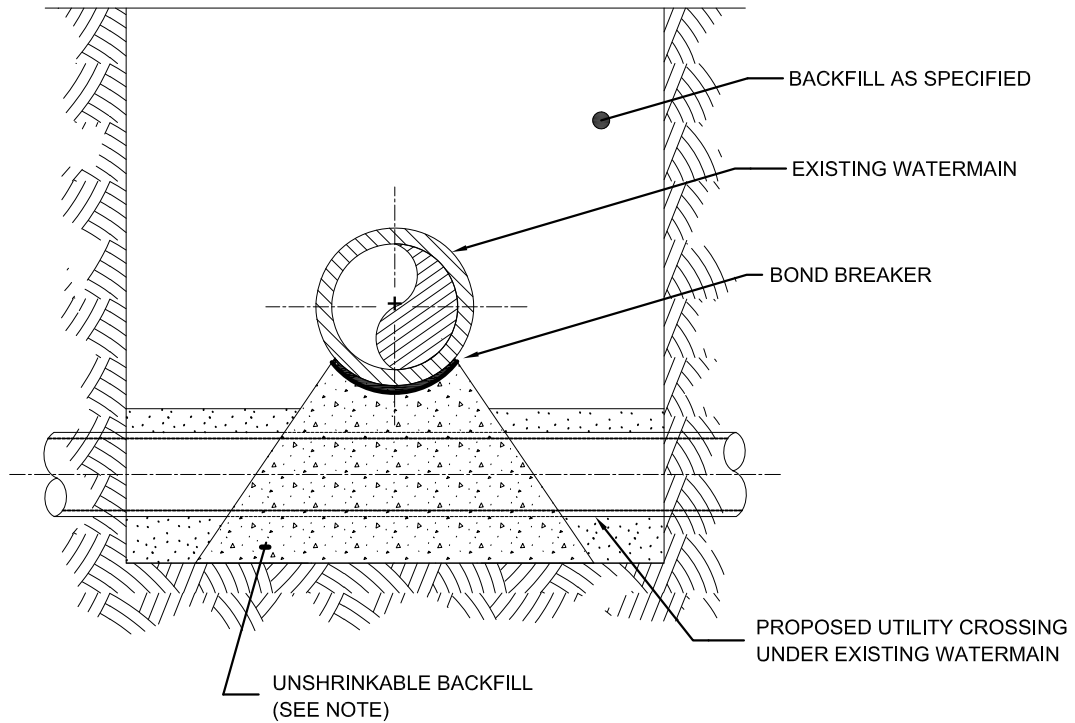

- NOTE:**
- 1) **WEAKLY CEMENTED FILL:**  
MEANS ANY COMBINATION OF GRANULAR MATERIALS WITH LOW PERCENTAGES OF CEMENT AND/OR OTHER CEMENTITIOUS MATERIAL SUCH THAT THE STRENGTH IS IN THE ORDER OF 0.4MPA AT 28 DAYS.
  - 2) BOND BREAKER TO BE PLACED BETWEEN THE WATERMAIN AND THE UNSHRINKABLE FILL.



**BACKFILL REQUIREMENTS FOR  
UTILITY CROSSINGS  
UNDERNEATH EXISTING  
WATERMAINS**

ENGINEERING SERVICES  
DEPARTMENT

DATE: NOV. 1989

N.T.S.

REV: NOV. 2021

**W-313**

DRAWN BY:  
A. SCHOEN

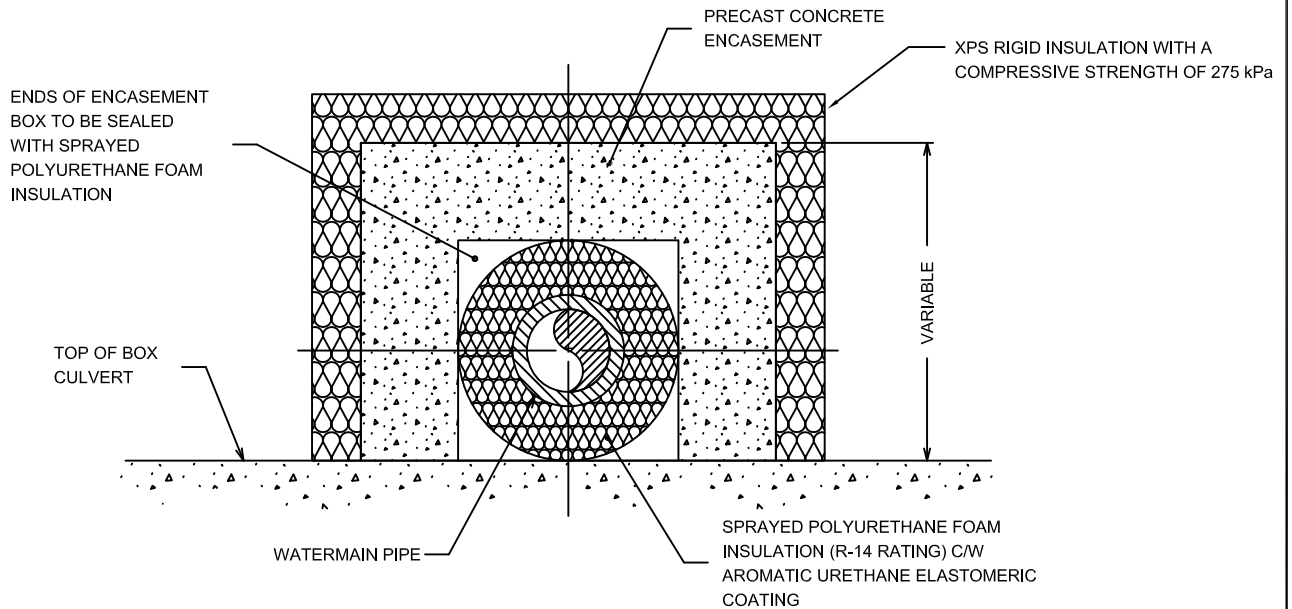
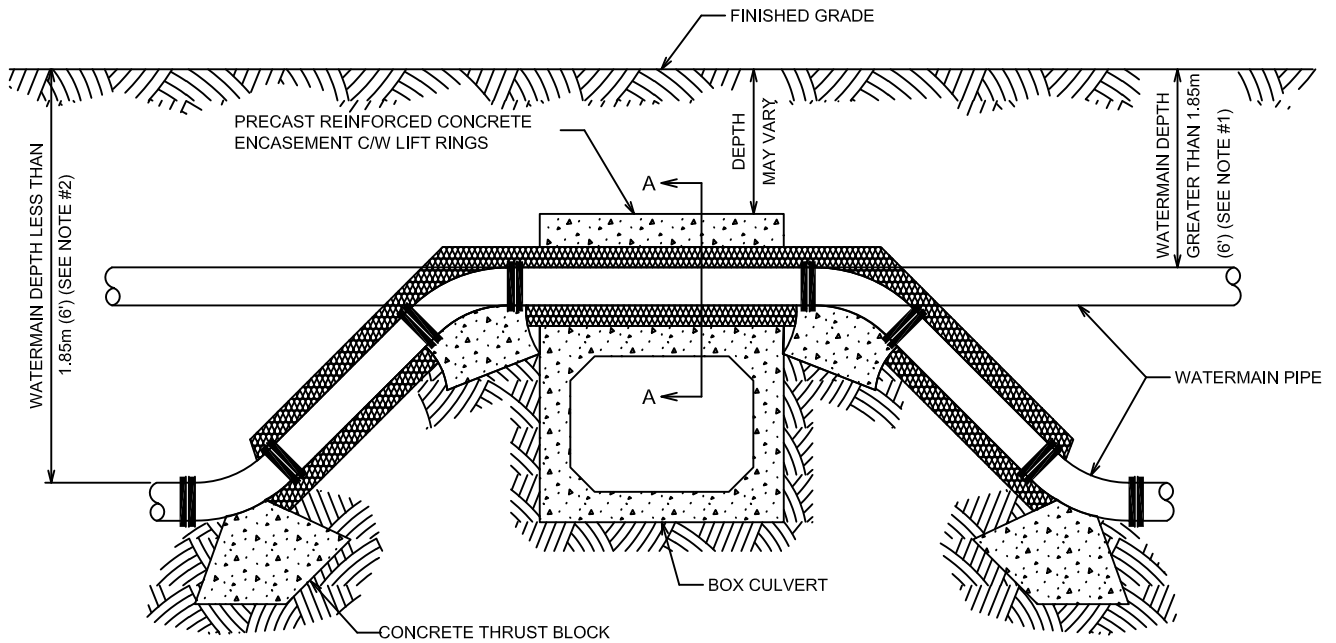

**SECTION A-A**

**NOTES:**

1. WATERMANS WITH DEPTHS GREATER THAN 1.85m (6') SHALL BE INSULATED (SPRAY POLYURETHANE) IN PRECAST CONCRETE ENCASUREMENT ONLY.
2. WATERMANS WITH DEPTHS LESS THAN 1.85m (6') SHALL HAVE 45° BENDS AND INSULATED (SPRAYED POLYURETHANE) IN PRECAST CONCRETE ENCASUREMENT AND DOWN TO BOTTOM OF BENDS ON EITHER SIDE OF THE BOX CULVERT.
3. INSTALLATION OF 45° BENDS SHALL BE RESTRAINED WITH MECHANICAL RESTRAINERS AND THRUST BLOCKS.
4. CASING SPACERS AS REQUIRED AND TO BE APPROVED BY GENERAL MANAGER OF PUBLIC WORKS OR DESIGNATE.



**WATERMAIN ENCASUREMENT  
OVER BOX CULVERT**

ENGINEERING SERVICES  
DEPARTMENT

DATE: FEB. 1991  
REV: NOV. 2021

N.T.S.

**W-314**

DRAWN BY:  
A. SCHOEN

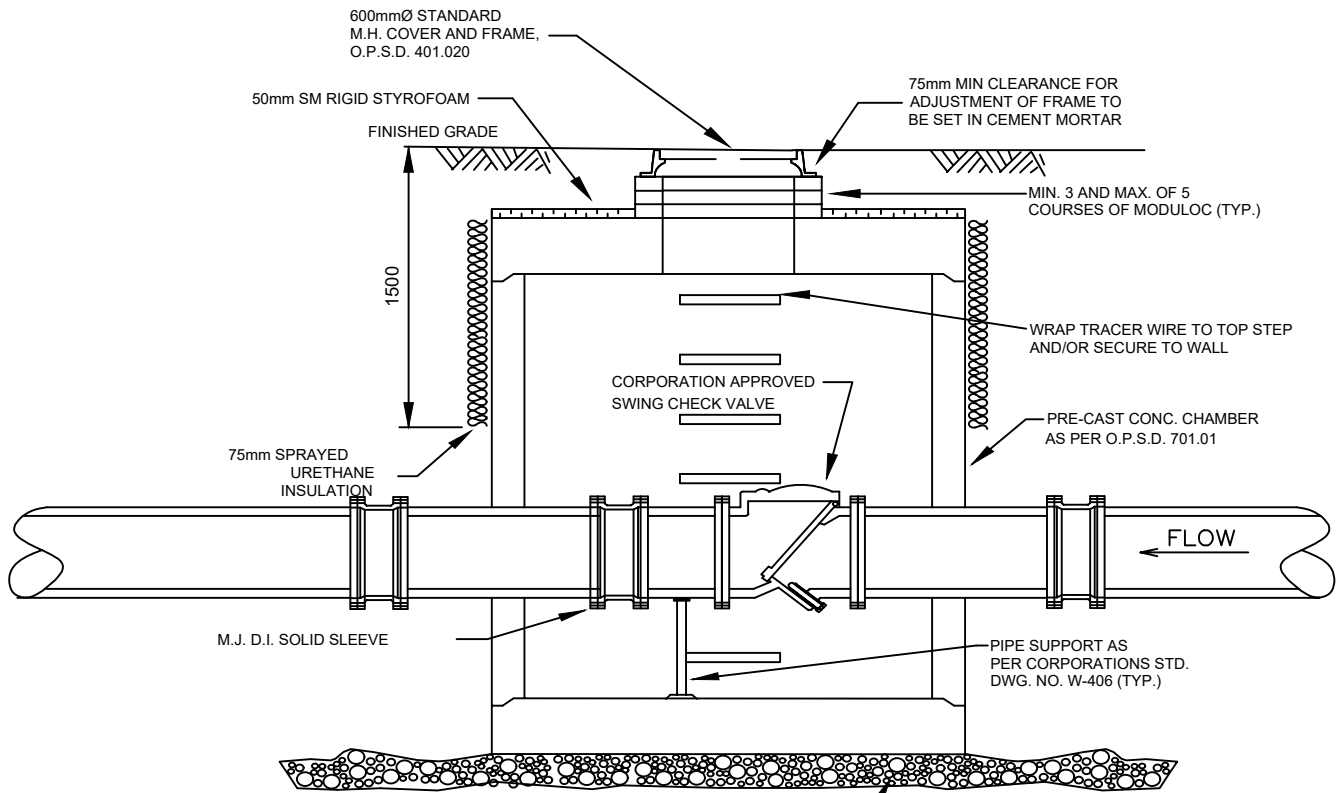
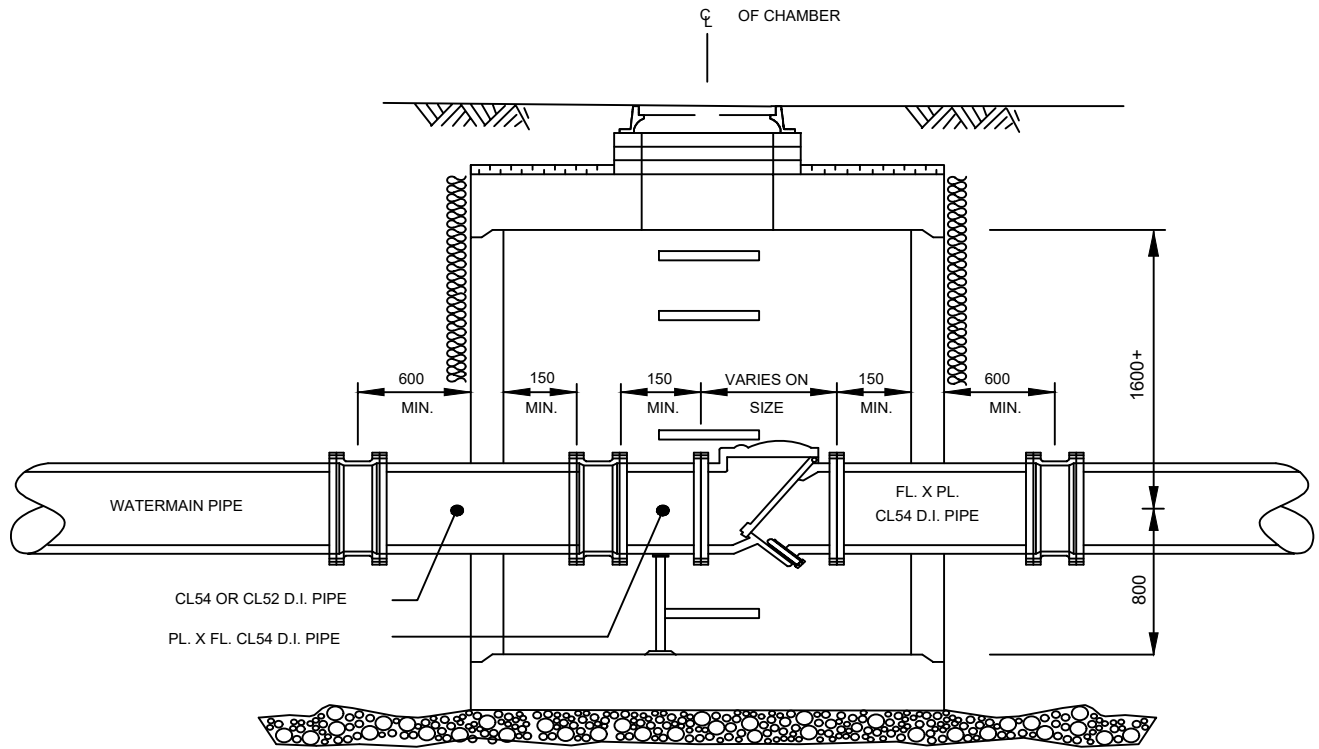

NOTE: ALL DUCTILE IRON PIPES, FITTINGS AND VALVE TO BE COVERED WITH PETROLATUM MATERIALS.



## TYPICAL SWING CHECK VALVE CHAMBER

ENGINEERING SERVICES DEPARTMENT

DATE: MAR. 2003	N.T.S.
REV: JAN 2024	
<b>W-315</b>	DRAWN BY: J. RATANAVANH

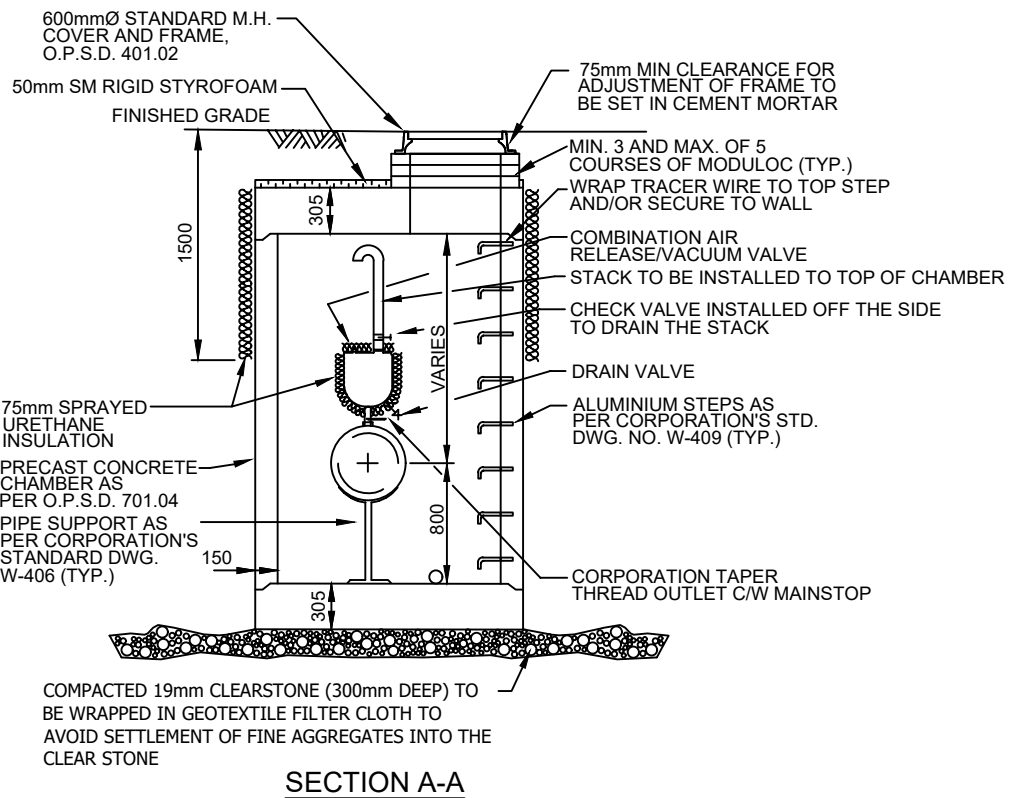
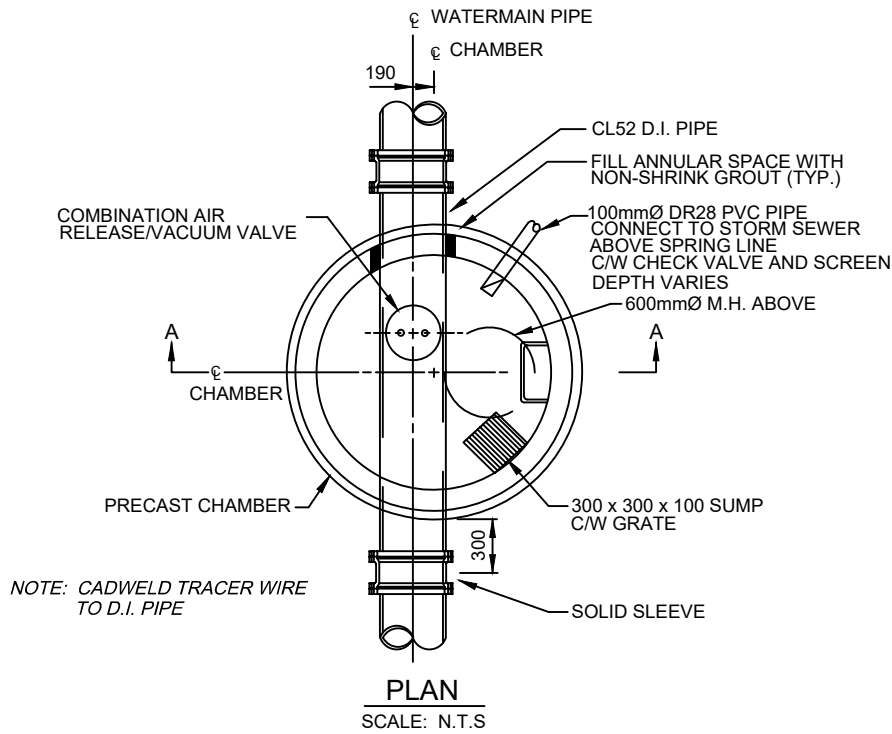

NOTE: 1) SIZES OF VALVE AND CHAMBER TO BE APPROVED BY CITY'S ENGINEER.  
 2) SADDLE WILL BE REQUIRED FOR MAINSTOP LARGER THAN 25mm.



## COMBINATION AIR RELEASE/AIR VACUUM VALVE CHAMBER

ENGINEERING SERVICES  
 DEPARTMENT

DATE: JAN. 2008

N.T.S.

REV: JAN. 2024

W-316

DRAWN BY:  
 J. RATANAVANH

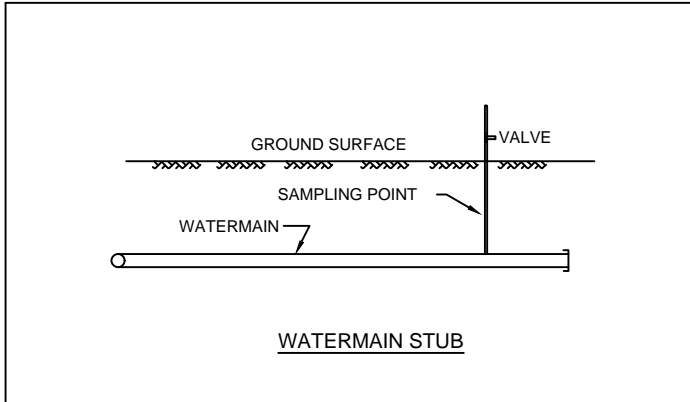
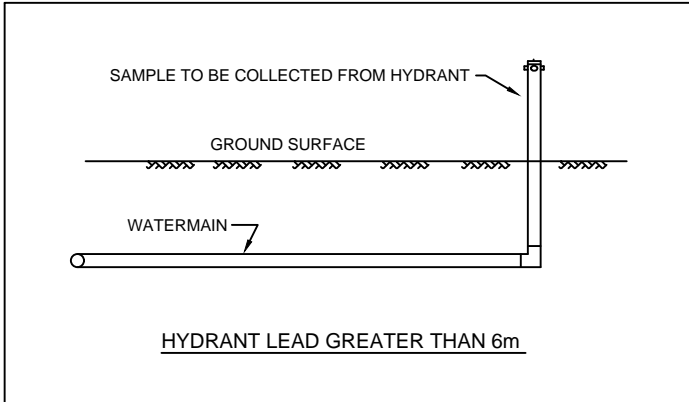
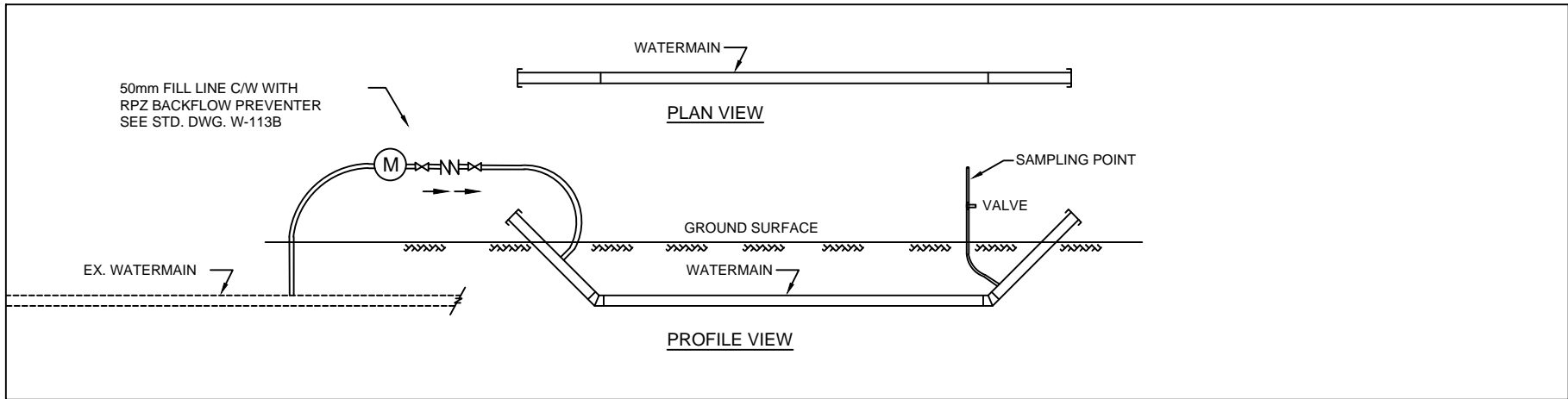

- 1) ALL SAMPLING LINES MUST BE A MINIMUM SIZE OF 25mm NEW COPPER AND TAP AT A CITY APPROVED LOCATION.
- 2) NO SAMPLING POINTS ARE TO BE TAPPED INTO THE CAP OR PLUG.

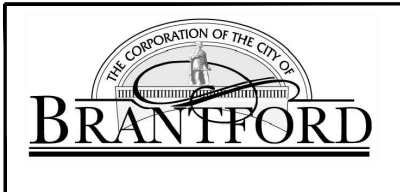

## BACTERIOLOGICAL SAMPLING POINTS

N.T.S. ENGINEERING SERVICES DEPARTMENT	
DATE: JAN. 2012	
REV: FEB. 2023	
<b>W-317</b>	DRAWN BY: J. RATANAVANH



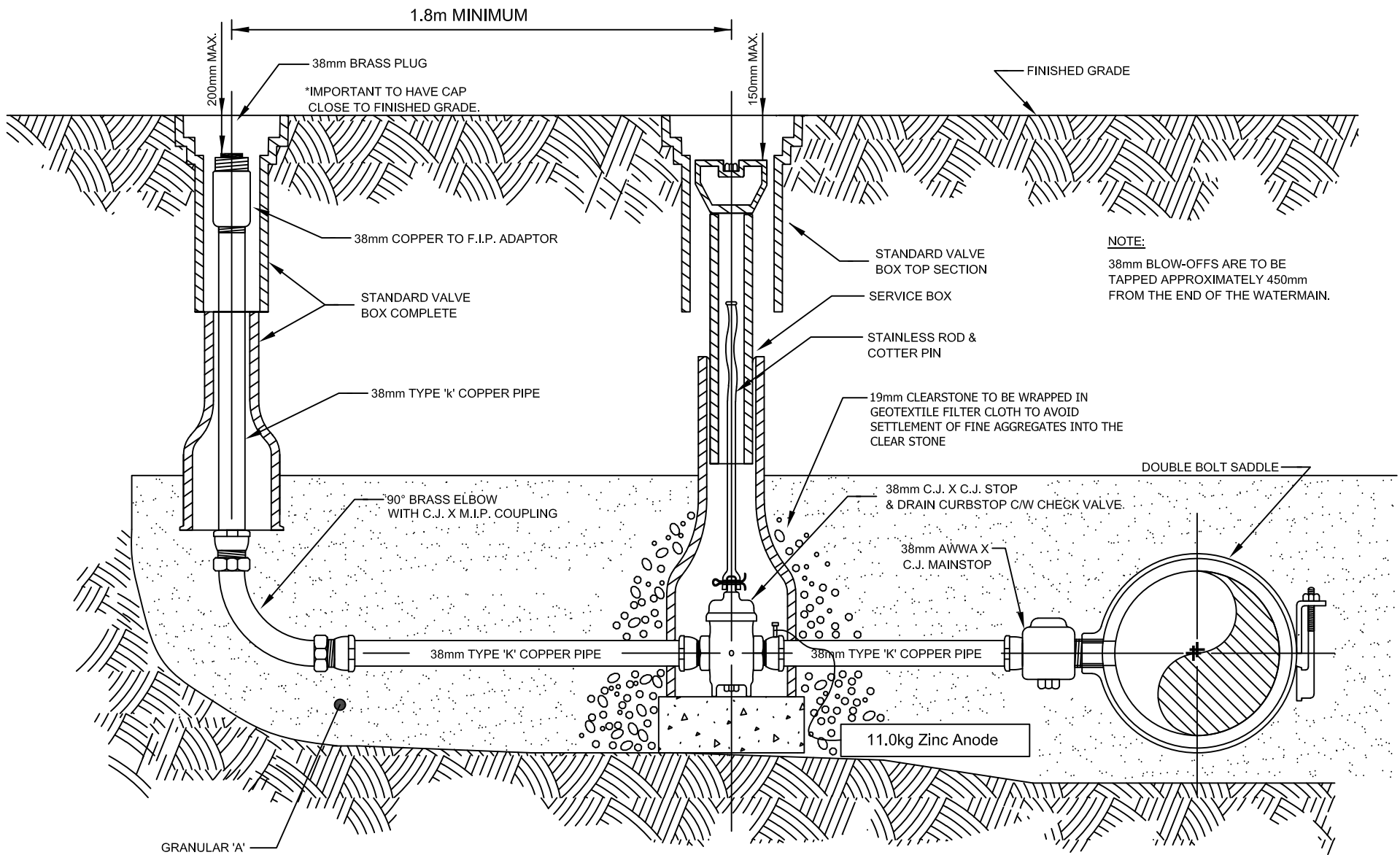

## STANDARD 38mm COPPER BLOW-OFF INSTALLATION

ENGINEERING SERVICES  
DEPARTMENT

DATE: JAN. 2018

REV: NOV. 2021

N.T.S.

W-318

DRAWN BY:  
J. RATANAVANH

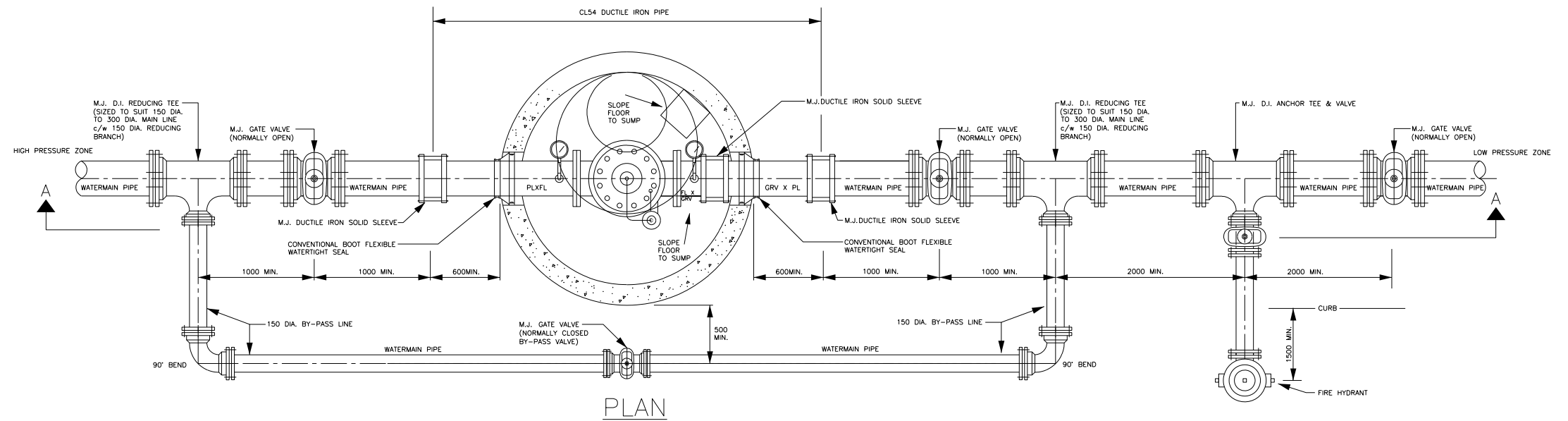

**SUPPLEMENTAL INSTRUCTIONS**

PRESSURE REDUCING VALVES SHALL MAINTAIN A CONSTANT DOWNSTREAM PRESSURE REGARDLESS OF VARYING INLET PRESSURE. PRESSURE REDUCING VALVES SHALL BE CAST OR DUCTILE IRON BODY WITH FLAT FACE FLANGES CONFORMING IN DIMENSIONS AND DRILLINGS TO ANSI B16.1 AND CLASS 125 OR AWWA C110-03 STANDARDS EQUIPPED WITH A HYDRAULICALLY OPERATED, DIAPHRAGM-ACTUATED, GLOBE VALVE ASSEMBLY. THEY SHALL INCLUDE STAINLESS STEEL TRIM SEATS, AN EXTERNAL POSITION INDICATOR, AND 6MM PET-COCKS ON THE INLET AND OUTLET SIDE OF THE VALVE. A SEPARATE PETCOCK SHALL BE SUPPLIED ON THE INLET & OUTLET SIDE OF THE VALVE TO ACCOMMODATE PRESSURE GAUGES. THE PILOT CONTROL SYSTEM SHALL HAVE AN EXTERNAL STRAINER AND DIRECT ACTING, ADJUSTABLE, SPRING LOADED, NORMALLY OPEN DIAPHRAGM VALVE WITH AN ALL STAINLESS STEEL BODY, C/W 316 STAINLESS STEEL BOLTS. PRESSURE REDUCING VALVES WITH OPTIONAL FLOW MONITORING CAPABILITY SHALL BE PREFERRED.

**NOTES**

1. MAIN-LINE VALVES TO REMAIN IN OPEN POSITION.
2. GATE VALVE PLACED ON THE BY-PASS TO REMAIN IN THE CLOSED POSITION.
3. ALL FITTINGS TO BE MECHANICALLY RESTRAINED.
4. NO SERVICE SHALL BE CONNECTED WITHIN COMPLETE PRV AREA.
5. CHAMBER LOCATIONS AND ELEVATIONS TO BE CO-ORDINATED WITH DEPTHS OF CURB & GUTTER LOCATIONS AND ROAD ELEVATION CHANGE DUE TO CROSS-FALL FROM ROAD CENTRELINE. PROVIDE MINIMUM DEPTH OF 350mm FROM FINAL GRADE TO TOP OF ACCESS CAP (CAP FOR VALVE REMOVAL) AS SHOWN.
6. SHOP DRAWING SUBMISSIONS ARE REQUIRED FOR ALL CHAMBERS. CONTRACTOR TO FIELD VERIFY AND PROVIDE ALL CHAMBER ELEVATIONS REQUIRED INCLUDING FINAL GRADE AND PIPE INVERT AT ACTUAL CHAMBER LOCATIONS.
7. REFER TO CONTRACT DESIGN DRAWINGS FOR REQUIRED VALVE OPTIONS AT EACH PROJECT-SPECIFIC VALVE CHAMBER

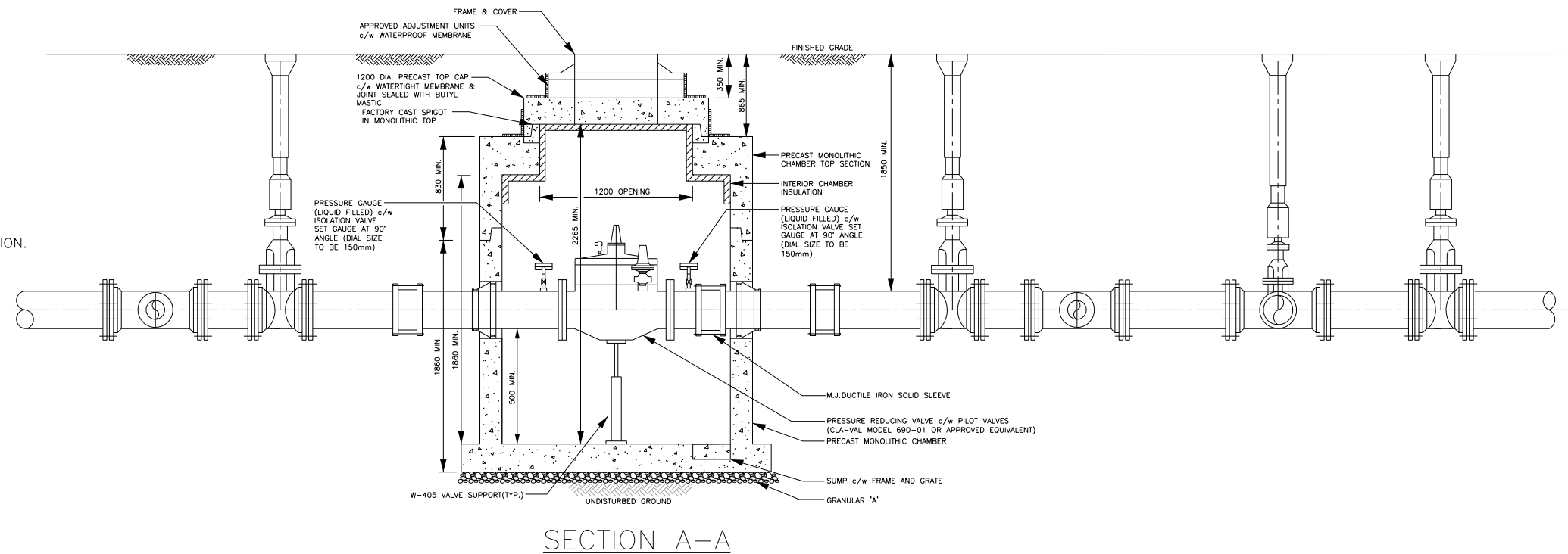

# PRESSURE REDUCING VALVE CHAMBER

ENGINEERING SERVICES DEPARTMENT

DATE: JAN. 2021

REV: NOV. 2021

N.T.S.

W-319

DRAWN BY:  
E. KERR

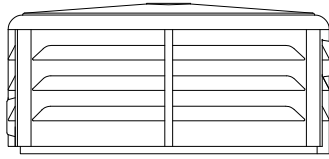

150mmØ SCH. 40  
GALVANIZED STEEL PRIMED  
C/W YELLOW POLY  
BOLLARD SLEEVE

CONCRETE FILL

FINISHED GRADE

355 Ø  
CONCRETE  
FOUNDATION

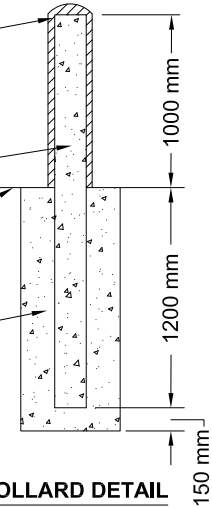

**CONCRETE BOLLARD DETAIL**  
NTS

**NOTES**

Automatic flushing device shall have a 2" stainless steel FIP inlet that will extend vertically to the bottom of a 2" automatic flushing valve. The flushing valve shall have a 150 PSI rating. Each unit shall be furnished with a stand-alone valve controller. Controller must have minimum of 12 possible flushing cycles per day. Controller shall be submersible to 12 feet, operate with a 9 volt battery, and have resin-sealed electrical components. Each unit shall have an all stainless steel sampling point. Removal of the 2" valve shall be possible from above ground. Valve assembly shall be housed in a PVC enclosure and each unit shall be self-draining, non-freezing. All above-ground components shall be contained within a UV-Resistant locking cover. Automatic flushing device discharge shall be centered over drain.

Automatic flushing devices shall be supplied in accordance with the Design and Construction Manual - Linear Municipal Infrastructure Standards: Approved Products List.

Equivalent alternatives to concrete bollards may be accepted by Public Works upon request.

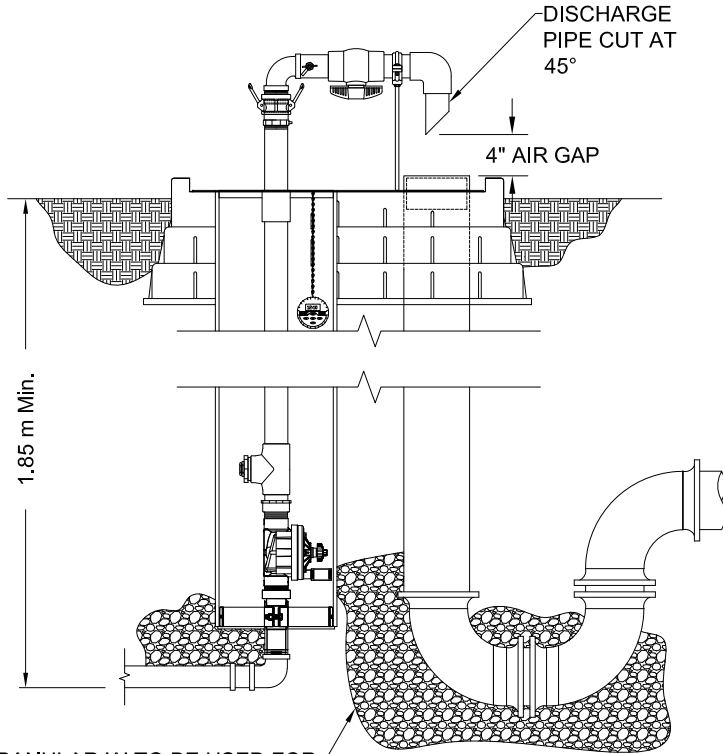

GRANULAR 'A' TO BE USED FOR  
BEDDING AND COVER TO WATER  
AND DRAIN CONNECTIONS

**AUTOMATIC FLUSHING DEVICE DETAIL**

NTS

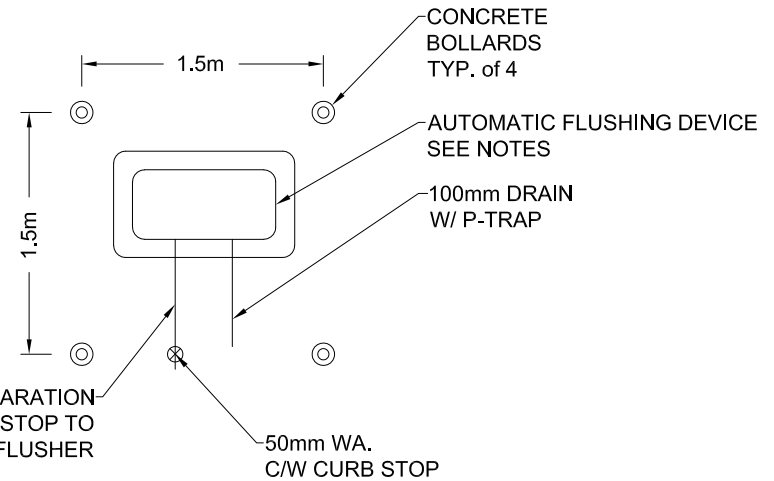

MINIMUM 0.6m SEPARATION  
FROM CURB STOP TO  
EDGE OF AUTOFLUSHER

**PLAN VIEW**

NTS



**AUTOMATIC FLUSHING DEVICE**

ENGINEERING SERVICES  
DEPARTMENT

DATE: MAR. 2022

REV:

**W-320**

N.T.S.

DRAWN BY:  
E.K.

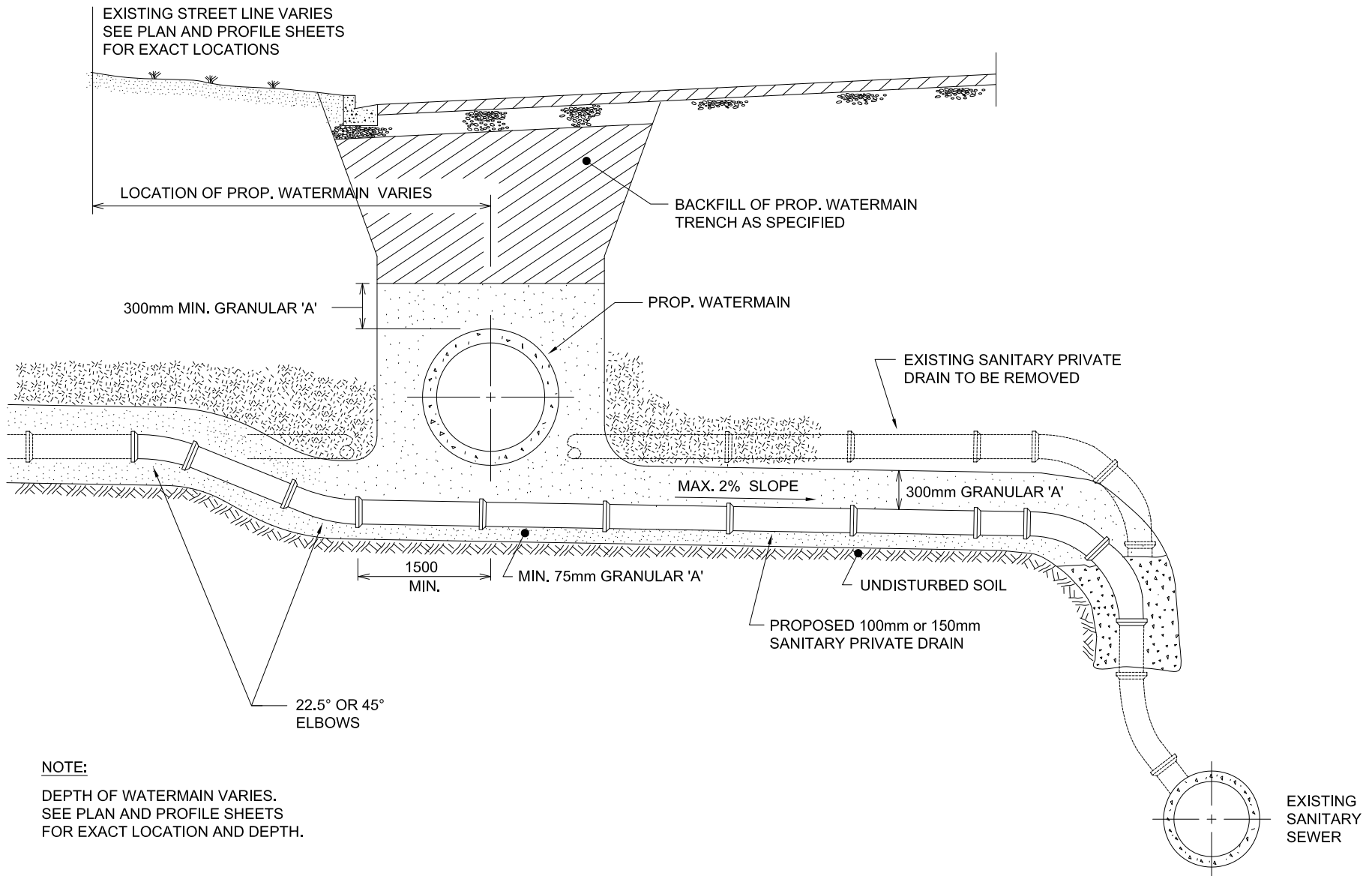

## PRIVATE DRAIN LOWERING DETAIL

ENGINEERING SERVICES  
DEPARTMENT

DATE: FEB. 1985

REV: NOV. 2021

N.T.S.

W-402

DRAWN BY:  
J. RATANAVANH

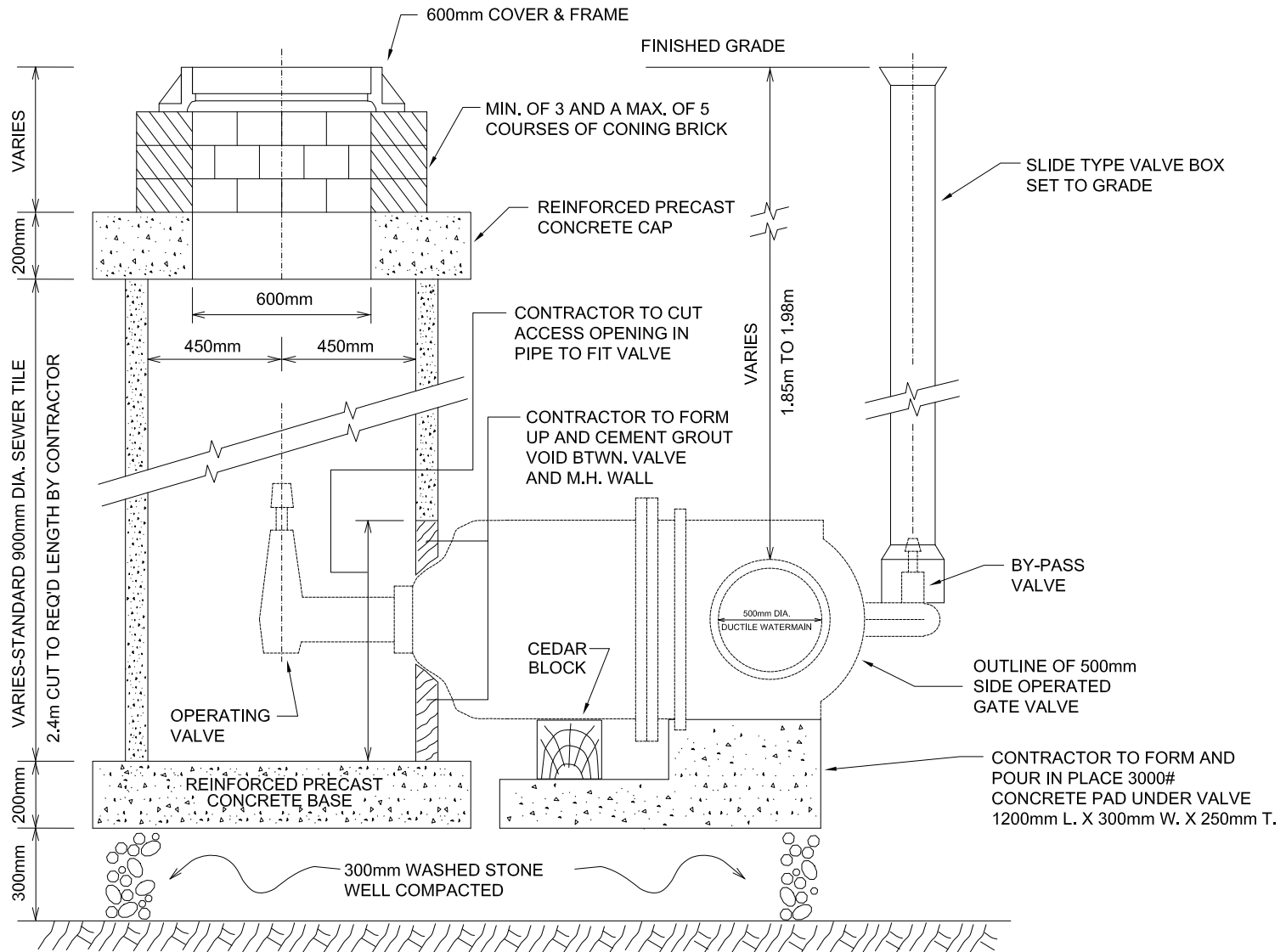

## VALVE CHAMBER FOR 500mm SIDE OPERATED GATE VALVE

ENGINEERING SERVICES  
DEPARTMENT

DATE: JAN. 1980

REV: NOV. 2021

N.T.S.

W-403

DRAWN BY:  
J. RATANAVANH

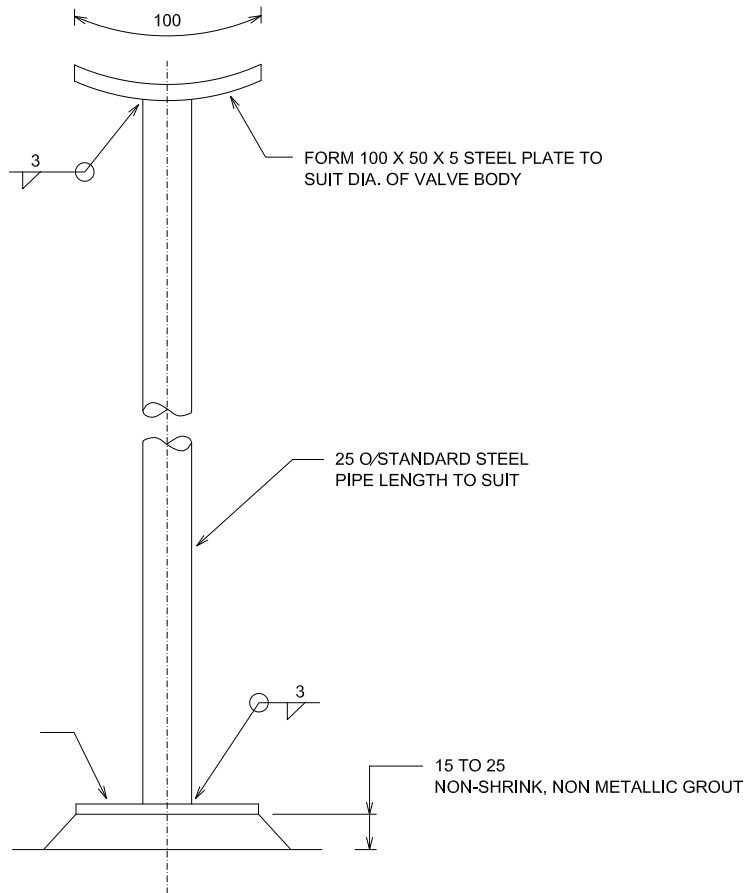

## PIPE AND VALVE SUPPORT

ENGINEERING SERVICES  
DEPARTMENT

DATE: JAN. 1985

N.T.S.

REV: NOV. 2021

**W-404**

DRAWN BY:  
J. RATANAVANH

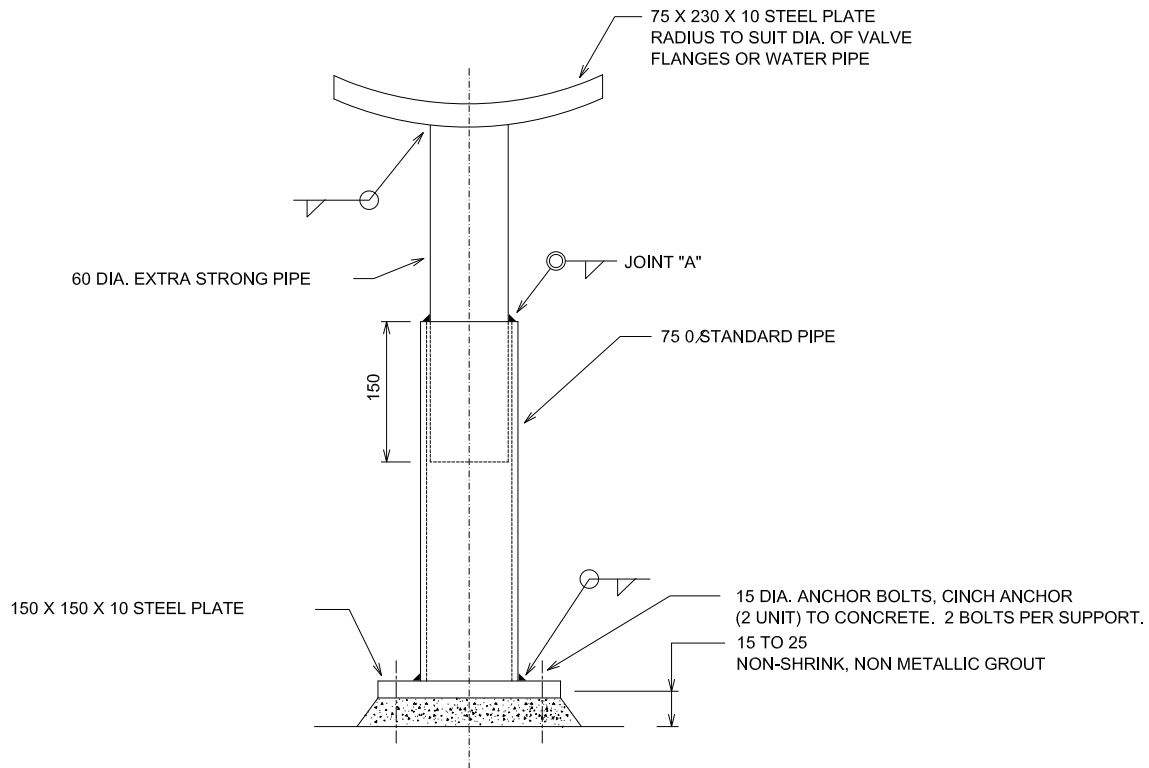

NOTE: CONTRACTOR SHALL ADJUST HEIGHT OF PIPE SUPPORT AND WELD AT JOINT "A", THEN GROUT BASE PLATE AS SPECIFIED SO THAT SUPPORT IS FIRMLY AGAINST VALVE OR WATER PIPE.



## VALVE SUPPORT

ENGINEERING SERVICES  
DEPARTMENT

DATE: JAN. 1985

REV: NOV. 2021

**W-405**

N.T.S.

DRAWN BY:  
J. RATANAVANH

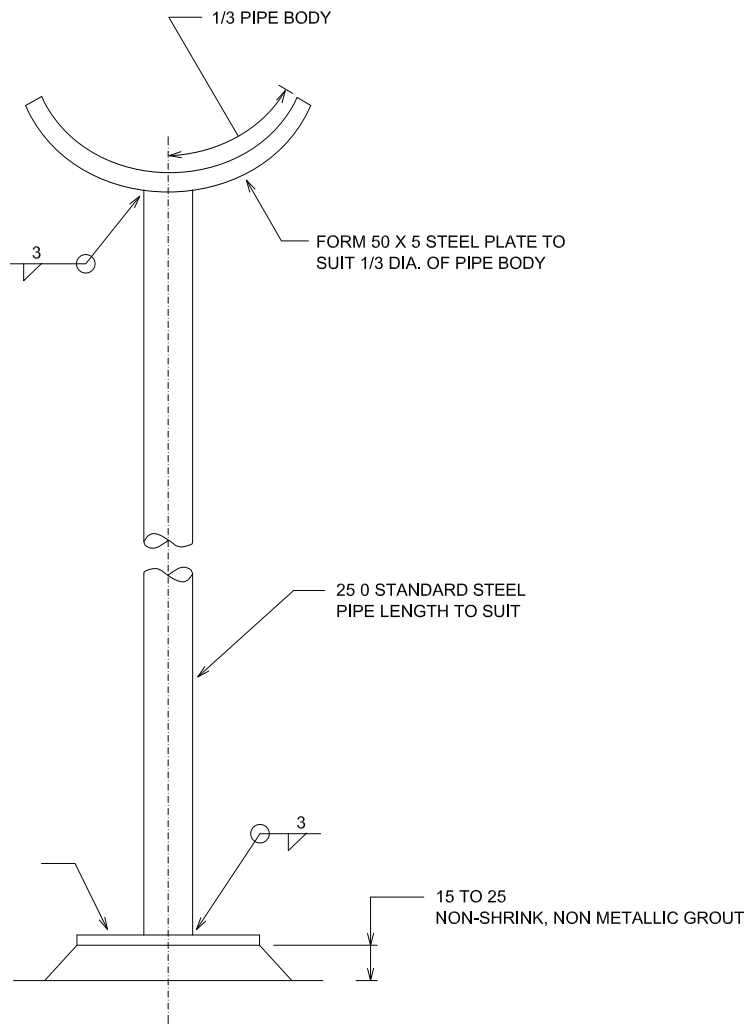

## PIPE SUPPORT

ENGINEERING SERVICES  
DEPARTMENT

DATE: FEB. 1986

N.T.S.

REV: NOV. 2021

**W-406**

DRAWN BY:  
J. RATANAVANH



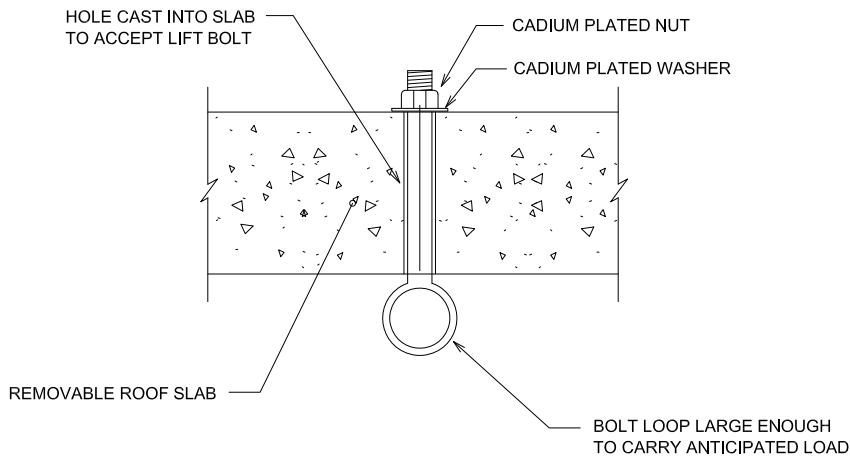

1. LIFT BOLT TO BE FIELD INSTALLED AFTER THE FLAT CAP IS INSTALLED.
2. REFER TO VALVE CHAMBER DRAWING LOCATION AND QUANTITY.



## LIFTING HOOK

ENGINEERING SERVICES  
DEPARTMENT

DATE: FEB. 1986

REV: NOV. 2021

**W-407**

N.T.S.

DRAWN BY:  
J. RATANAVANH

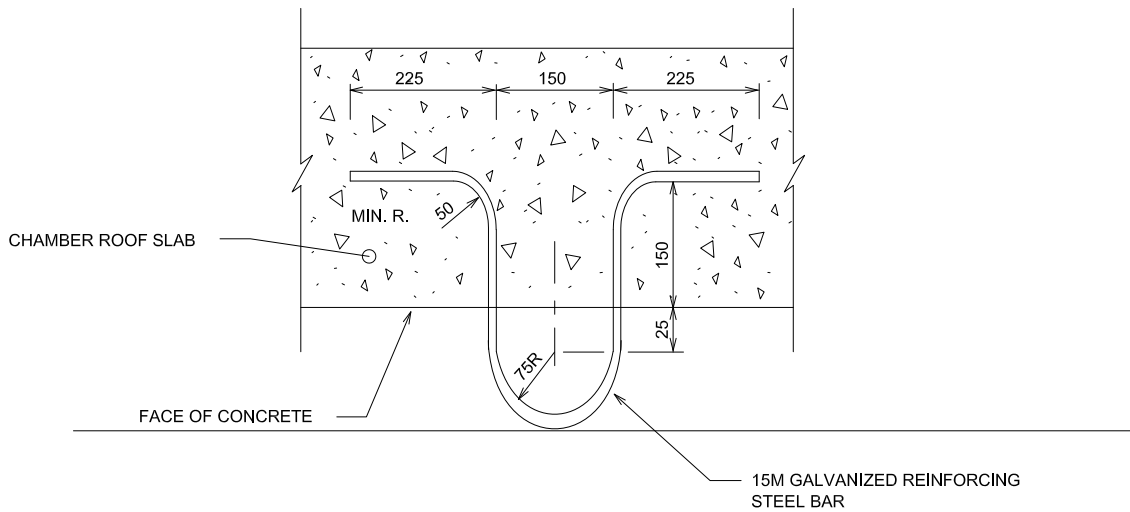

LIFTING HOOK TO BE LOCATED DIRECTLY ABOVE VALVES, ACCESS MANHOLES ETC. AS INDICATED ON VALVE CHAMBER DRAWINGS



## LIFTING HOOK DETAIL FOR CHAMBERS

ENGINEERING SERVICES DEPARTMENT

DATE: JAN. 1985

REV: NOV. 2021

N.T.S.

**W-408**

DRAWN BY:  
J. RATANAVANH

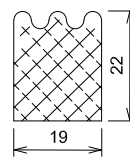
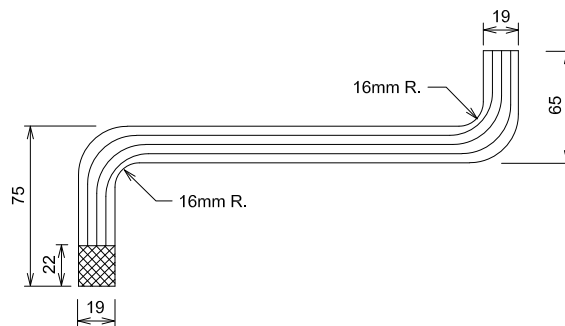
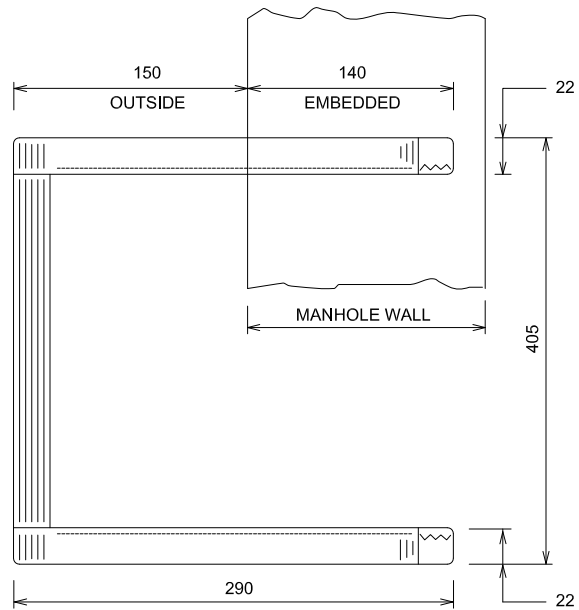

RUNG DETAIL

NOTE:

1. MATERIAL FOR STEPS TO BE ALUMINIUM ALLOY CSA-HA. 5.
2. DISTANCE BETWEEN STEPS TO BE 300mm.
3. DISTANCE FROM STEP TO TOP OF FLOOR TO BE 300mm MAXIMUM.
4. DISTANCE FROM BASE OF FRAME TO FIRST STEP TO BE 80mm.
5. 2 COATS STATIC ASPHALT PAINT OR APPROVED EQUAL ON EMBEDDED SECTION.



STANDARD MANHOLE  
STEPS-ALUMINIUM

ENGINEERING SERVICES  
DEPARTMENT

DATE: FEB. 1985  
REV: NOV. 2021

N.T.S.

W-409

DRAWN BY:  
J. RATANAVANH

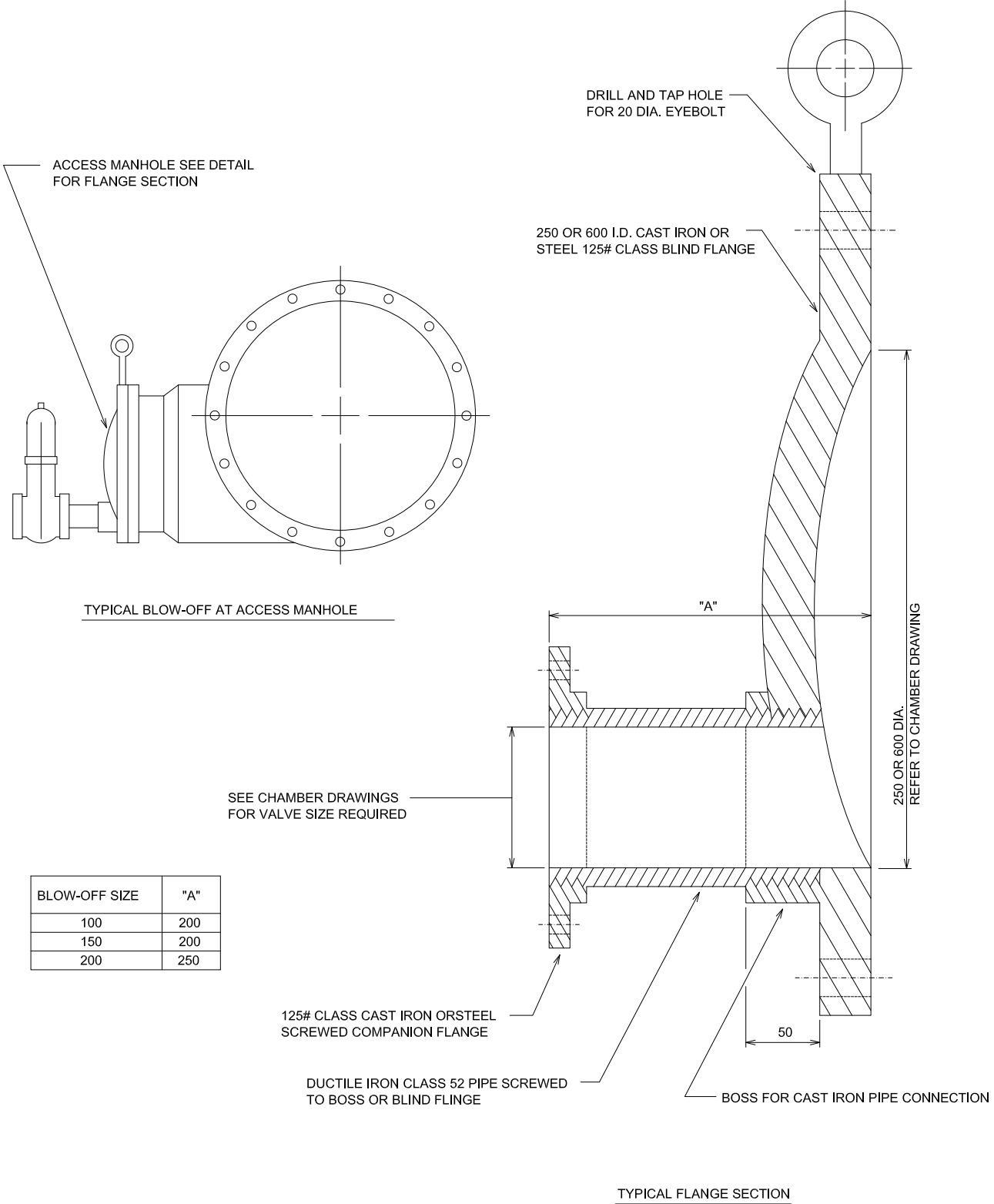

BLOW-OFF SIZE	"A"
100	200
150	200
200	250



## BLOW-OFF CONNECTION AT ACCESS CHAMBER

ENGINEERING SERVICES  
DEPARTMENT

DATE: FEB. 1986

REV: NOV. 2021

N.T.S.

W-410

DRAWN BY:  
J. RATANAVANH

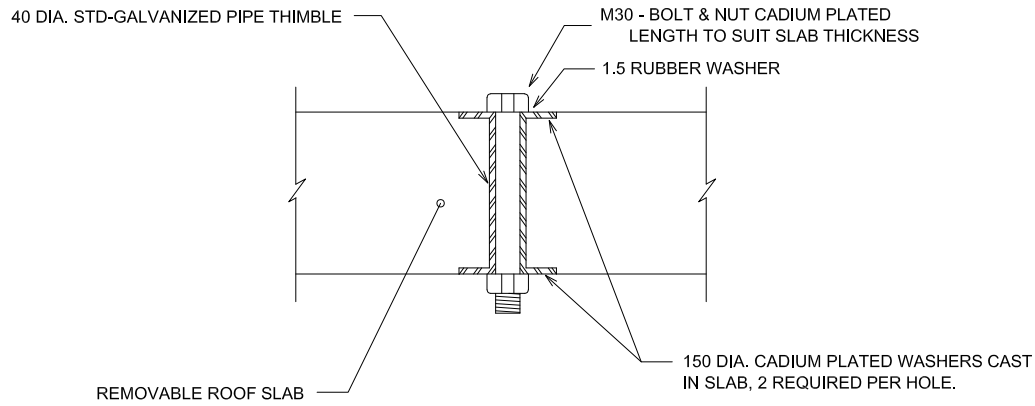

REFER TO VALVE CHAMBER DRAWING  
LOCATION AND QUANTITY.



## REMOVABLE SLAB LIFTING HOLE DETAILS

ENGINEERING SERVICES  
DEPARTMENT

DATE: JAN. 1985

REV: NOV. 2021

N.T.S.

**W-411**

DRAWN BY:  
J. RATANAVANH

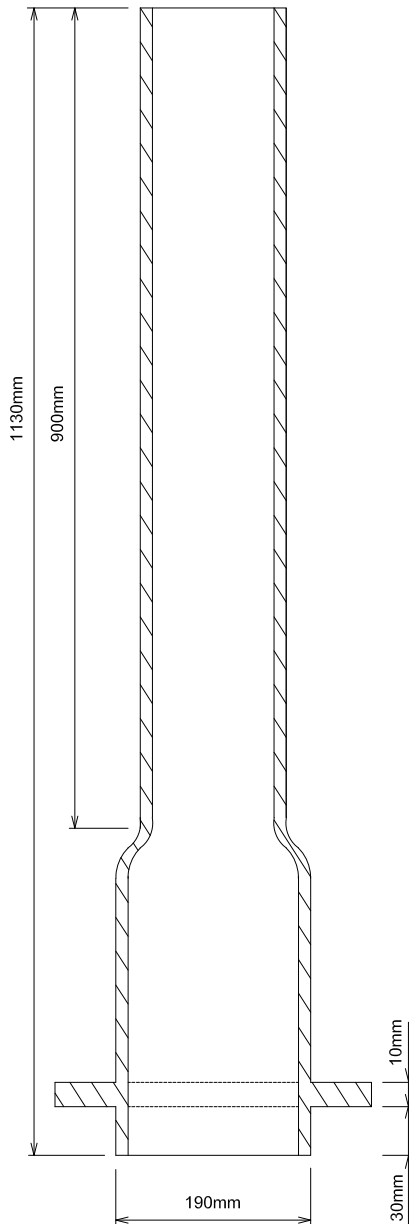

LOWER SECTION

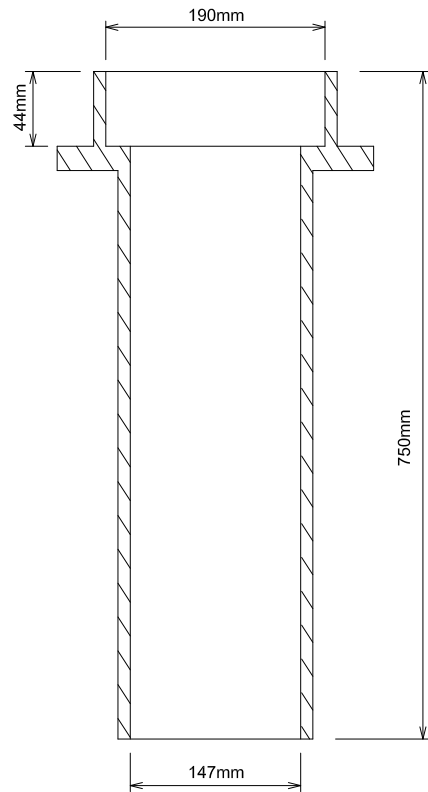
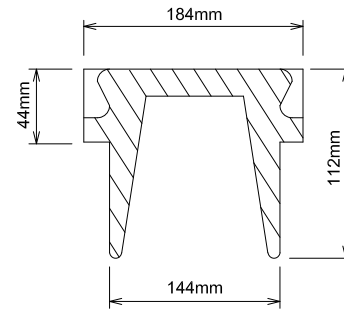

UPPER SECTION



CHAMBER VALVE BOX

ENGINEERING SERVICES  
DEPARTMENT

DATE: MAY 1986  
REV: NOV. 2021

N.T.S.

W-412

DRAWN BY:  
J. RATANAVANH

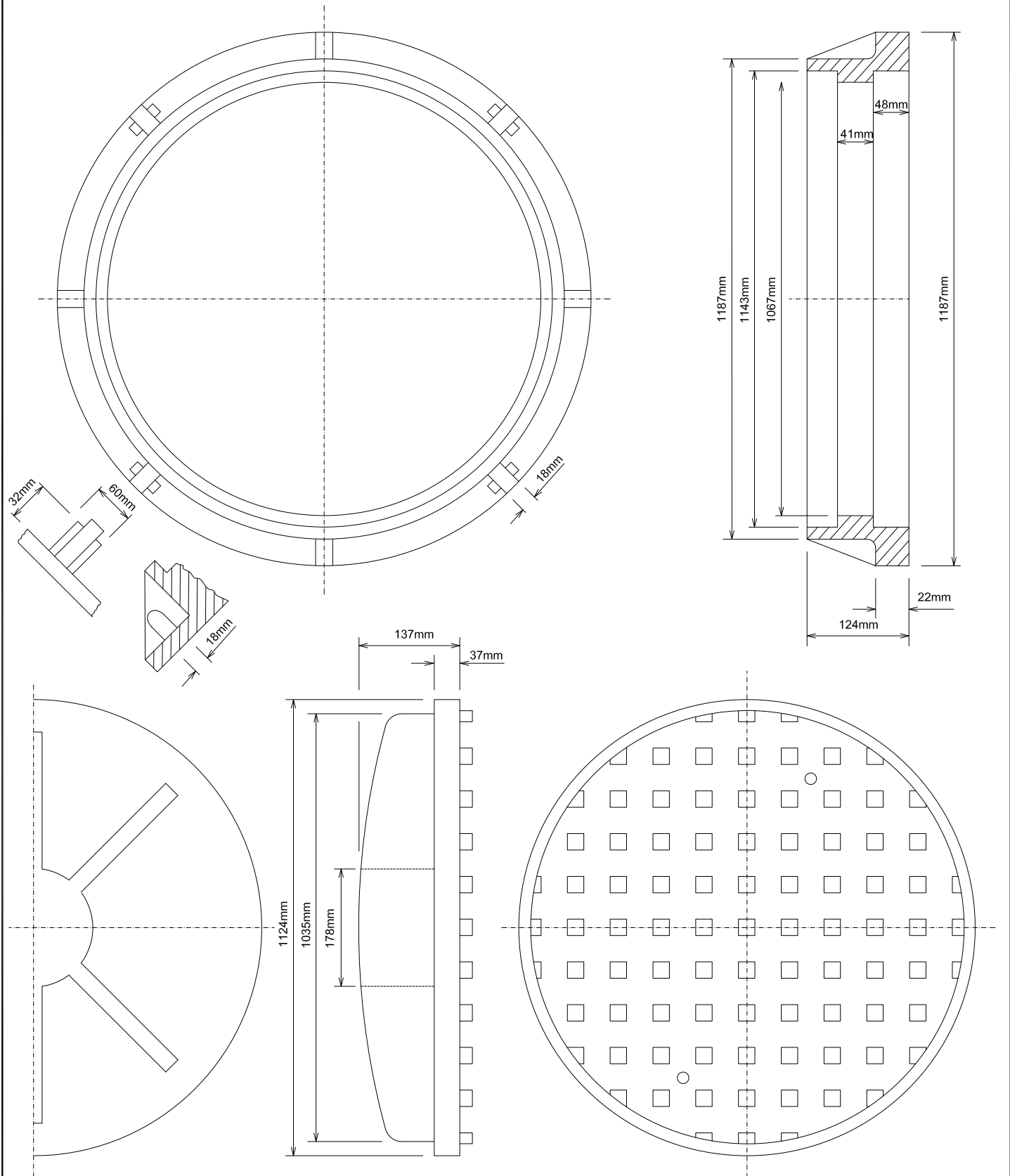

APPROXIMATE WEIGHT - 500Kg



# 1067mm HEAVY DUTY MANHOLE COVER & FRAME

ENGINEERING SERVICES  
DEPARTMENT

DATE: JAN. 1985  
REV: NOV. 2021

N.T.S.

W-413

DRAWN BY:  
J. RATANAVANH

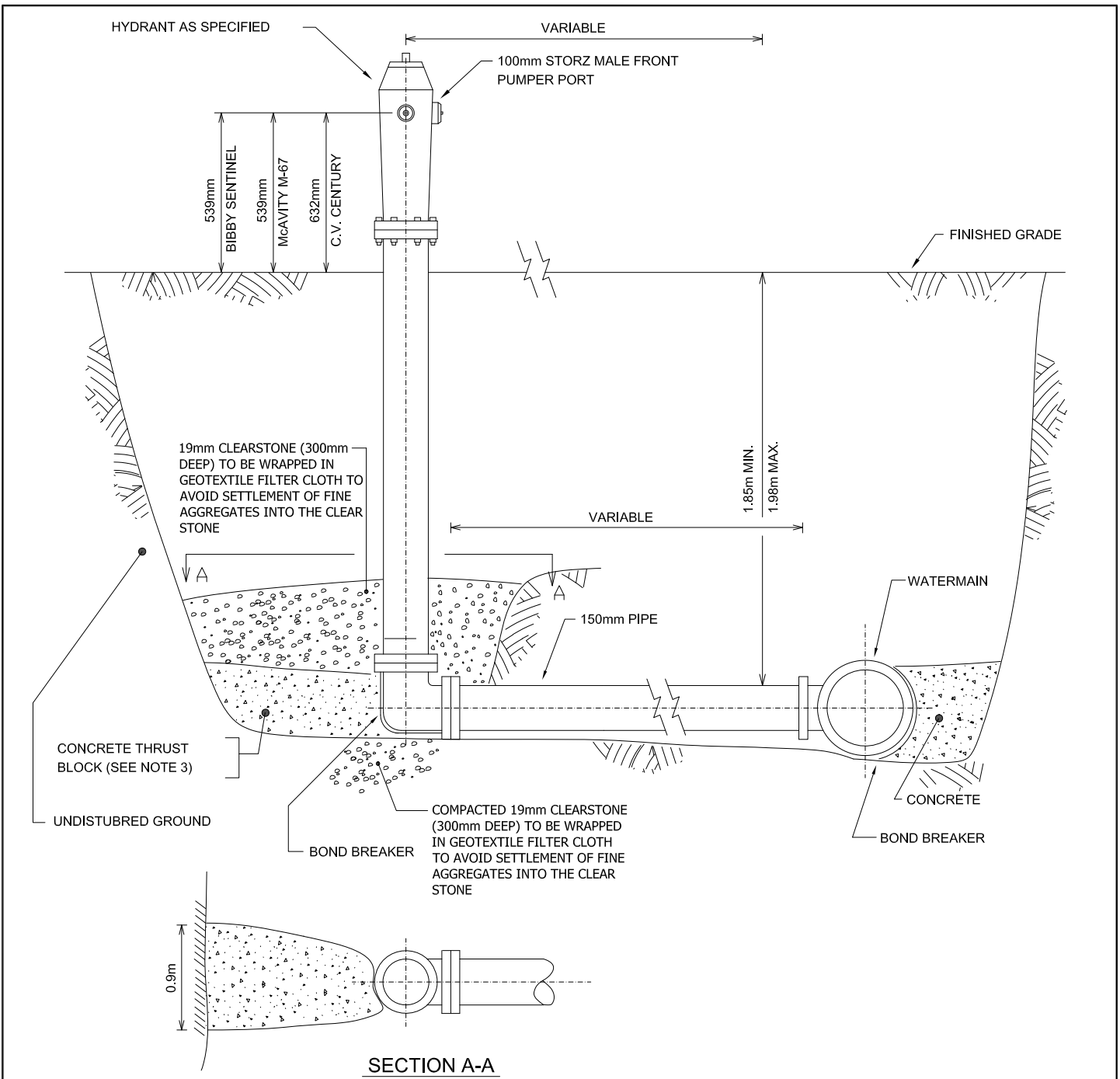

**NOTES:**

1. MIN. STRENGTH OF CONCRETE 20MPa UNLESS OTHERWISE SPECIFIED.
2. ALL CONCRETE BLOCK TO BE POURED AGAINST UNDISTURBED GROUND.
3. AS AN ALTERNATIVE TO CONCRETE THRUST BLOCK, HORIZONTAL TIE RODS FROM BOOT TO STREET MAIN WILL BE CONSIDERED. CONTRACTOR TO CONFIRM WITH CITY INSPECTOR.
4. APPROVED HYDRANTS ARE CANADA VALVE (CENTURY), McAVITY M-67, BIBBY SENTINEL, OR AVK 2780 NOSTALGIC. IF HYDRANT RISERS ARE REQUIRED, THEY SHALL BE INSTALLED AT THE BOOT OF THE CANADA VALVE(CENTURY), AT THE TOP OF THE McAVITY M-67 AND BIBBY SENTINEL.
5. PROVIDE 300mm OF CLEAR STONE BELOW BOOT.



**HYDRANT INSTALLATION**

ENGINEERING SERVICES  
DEPARTMENT

DATE: OCT. 1988

REV: NOV. 2021

**W-501**

N.T.S.

DRAWN BY:  
J. RATANAVANH



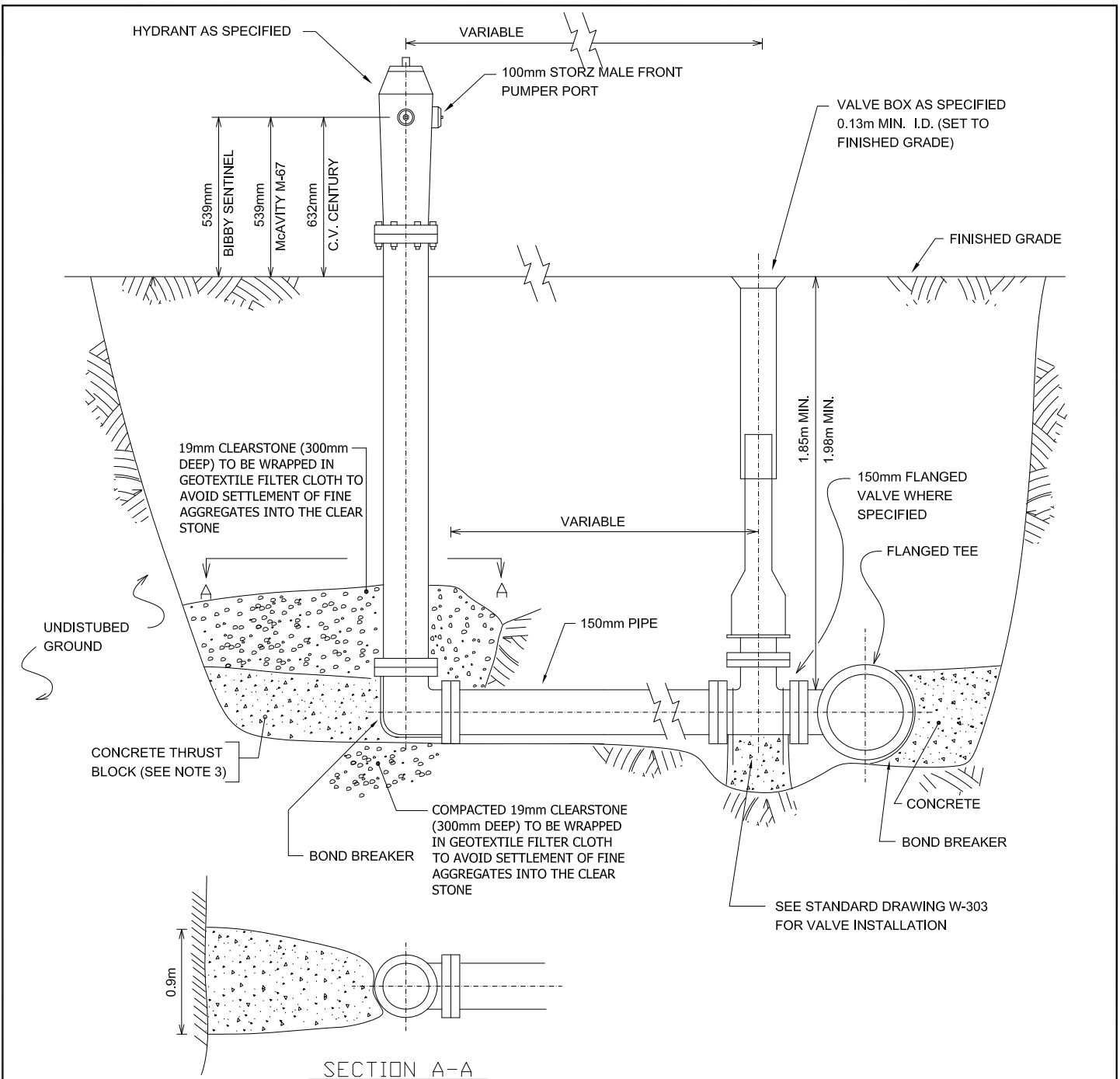

**NOTES:**

1. MIN. STRENGTH OF CONCRETE 20MPa UNLESS SPECIFIED OTHERWISE.
2. ALL CONCRETE BLOCKING TO BE POURED AGAINST UNDISTURBED GROUND.
3. AS AN ALTERNATIVE TO CONCRETE THRUST BLOCK, HORIZONTAL TIE RODS FROM BOOT TO STREET MAIN WILL BE CONSIDERED. CONTRACTOR TO CONFIRM WITH CITY INSPECTOR.
4. APPROVED HYDRANTS ARE CANADA VALVE(CENTURY), McAVITY M-67, BIBBY SENTINEL AND AVK 2780 NOSTALGIC. IF HYDRANT RISERS ARE REQUIRED, THEY SHALL BE INSTALLED AT THE BOOT OF THE CANADA VALVE(CENTURY), AT THE TOP OF THE McAVITY M-67 AND BIBBY SENTINEL..
5. PROVIDE 300mm OF CLEAR STONE BELOW BOOT.



## HYDRANT DETAIL WITH FLANGED TEE AND FLANGED GATE VALVE

ENGINEERING SERVICES  
DEPARTMENT

DATE: OCT. 1968

REV: NOV. 2021

**W-502**

N.T.S.

DRAWN BY:  
J. RATANAVANH

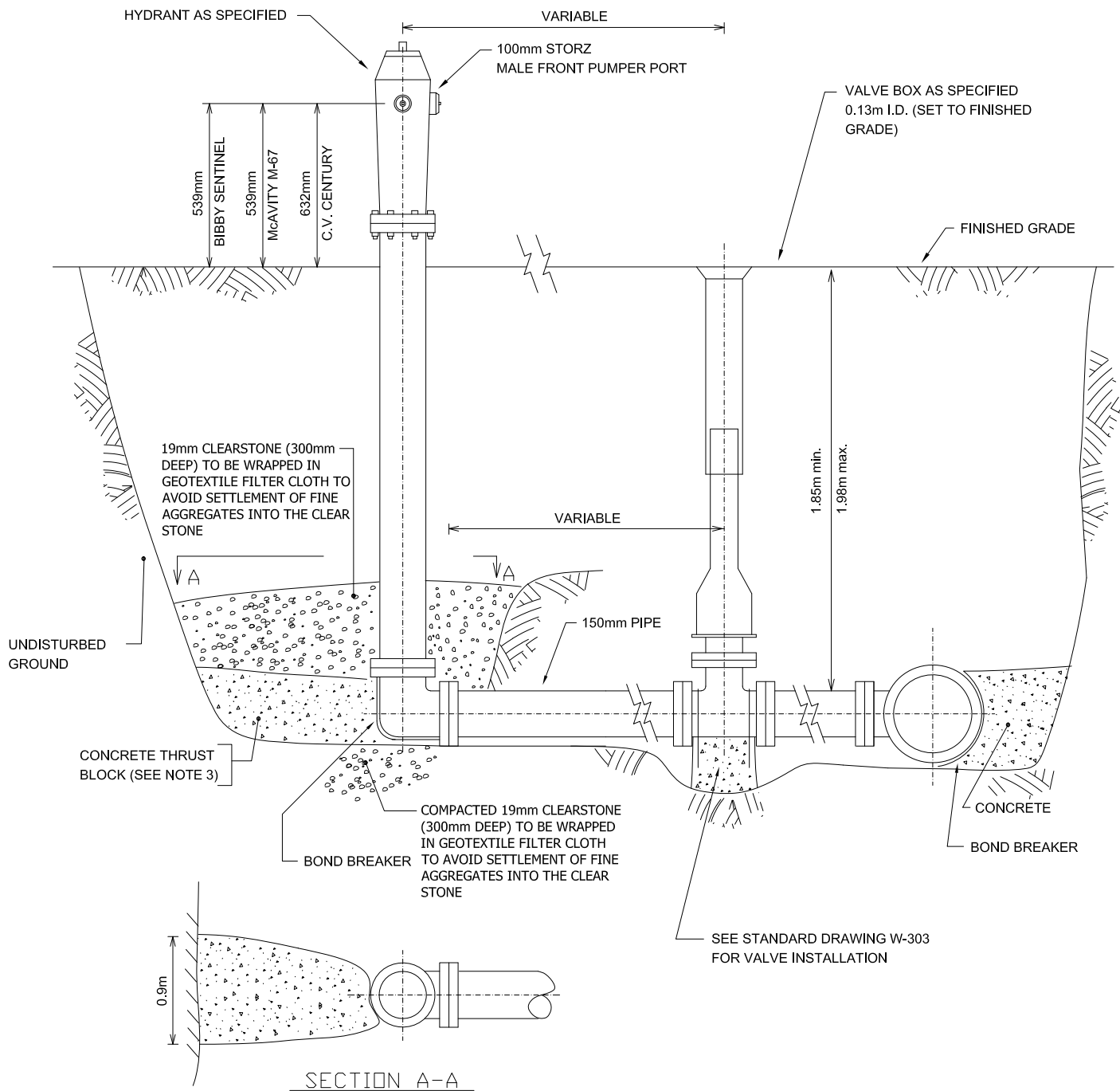

**NOTES:**

1. MIN. STRENGTH OF CONCRETE 20MPa UNLESS SPECIFIED OTHERWISE.
2. ALL CONCRETE BLOCK TO BE POURED AGAINST UNDISTURBED GROUND.
3. AS AN ALTERNATIVE TO CONCRETE THRUST BLOCK, HORIZONTAL TIE RODS FROM BOOT TO GATE VALVE WILL BE CONSIDERED. CONTRACTOR TO CONFIRM WITH CORPORATION'S INSPECTOR.
5. APPROVED HYDRANTS ARE CANADA VALVE (CENTURY), McAVITY M-67, BIBBY SENTINEL AND AVK 2780 NOSTALGIC. IF HYDRANT RISERS ARE REQUIRED, THEY SHALL BE INSTALLED AT THE BOOT OF THE CANADA VALVE (CENTURY), AT THE TOP OF THE McAVITY M-67 AND BIBBY SENTINEL.
6. PROVIDE 300mm DEPTH OF CLEAR STONE BELOW BOOT.



**HYDRANT INSTALLATION**

ENGINEERING SERVICES  
DEPARTMENT

DATE: JUNE 1985

REV: NOV. 2021

**W-503**

N.T.S.

DRAWN BY:  
J. RATANAVANH

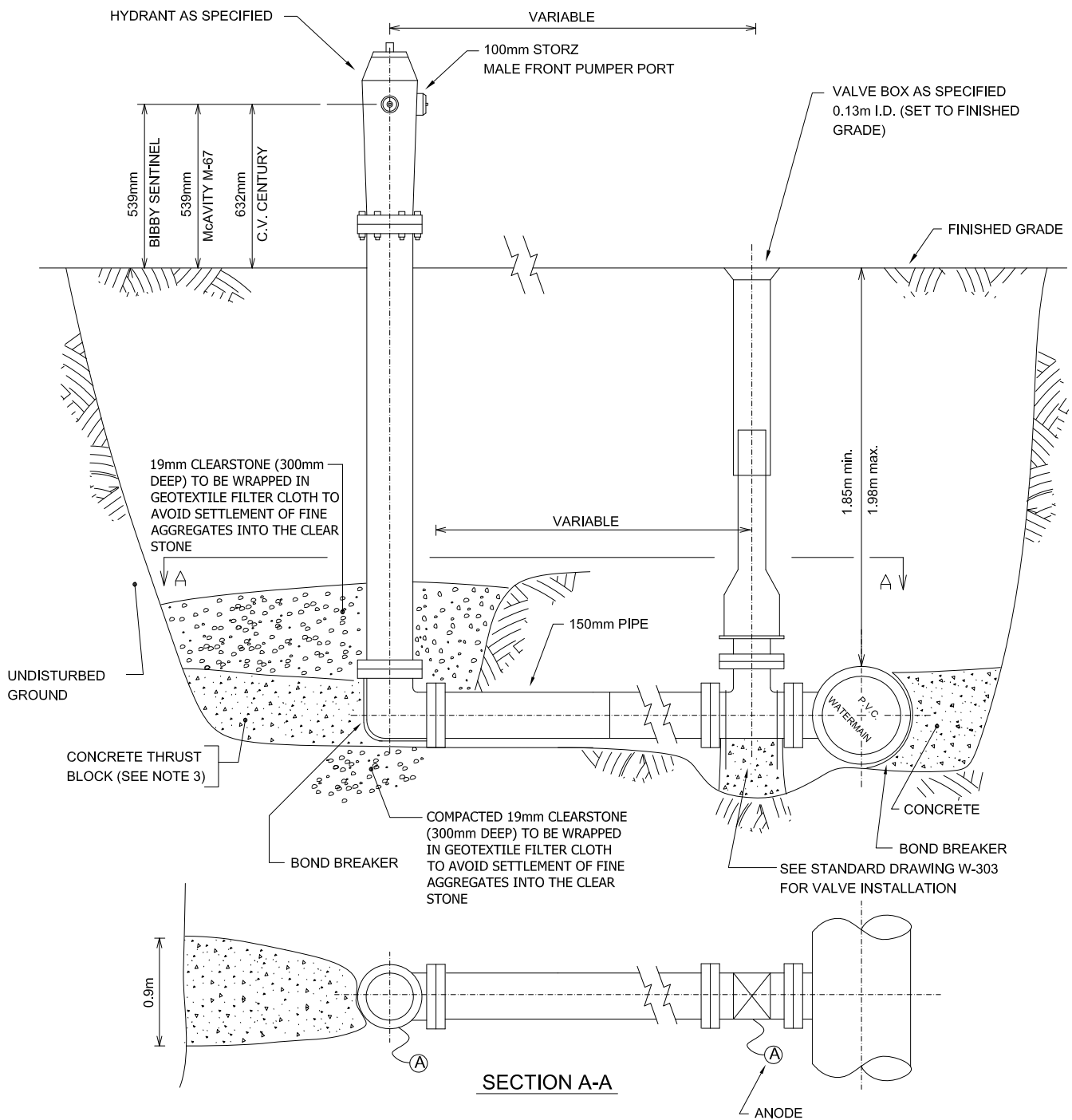

**NOTES:**

1. MIN. STRENGTH OF CONCRETE 20MPa UNLESS SPECIFIED OTHERWISE.
2. ALL CONCRETE BLOCK TO BE POURED AGAINST UNDISTURBED GROUND.
3. AS AN ALTERNATIVE TO CONCRETE THRUST BLOCK, HORIZONTAL TIE RODS FROM BOOT TO GATE VALVE WILL BE CONSIDERED. CONTRACTOR TO CONFIRM WITH CORPORATION'S INSPECTOR.
4. APPROVED HYDRANTS ARE DARLING CENTURY, McAVITY M.67, BIBBY SENTINEL AND AVK 2780 NOSTALIC. IF HYDRANT RISERS ARE REQUIRED, THEY SHALL BE INSTALLED AT THE BOOT OF THE DARLING CENTURY, AT THE TOP OF THE McAVITY M.67.
5. PROVIDE 300mm OF CLEAR STONE BELOW THE BOOT.



## HYDRANT INSTALLATION C/W ANCHOR TEE AND VALVE

ENGINEERING SERVICES DEPARTMENT

DATE: JULY 1985

REV: NOV. 2021

N.T.S.

W-504

DRAWN BY:  
J. RATANAVANH

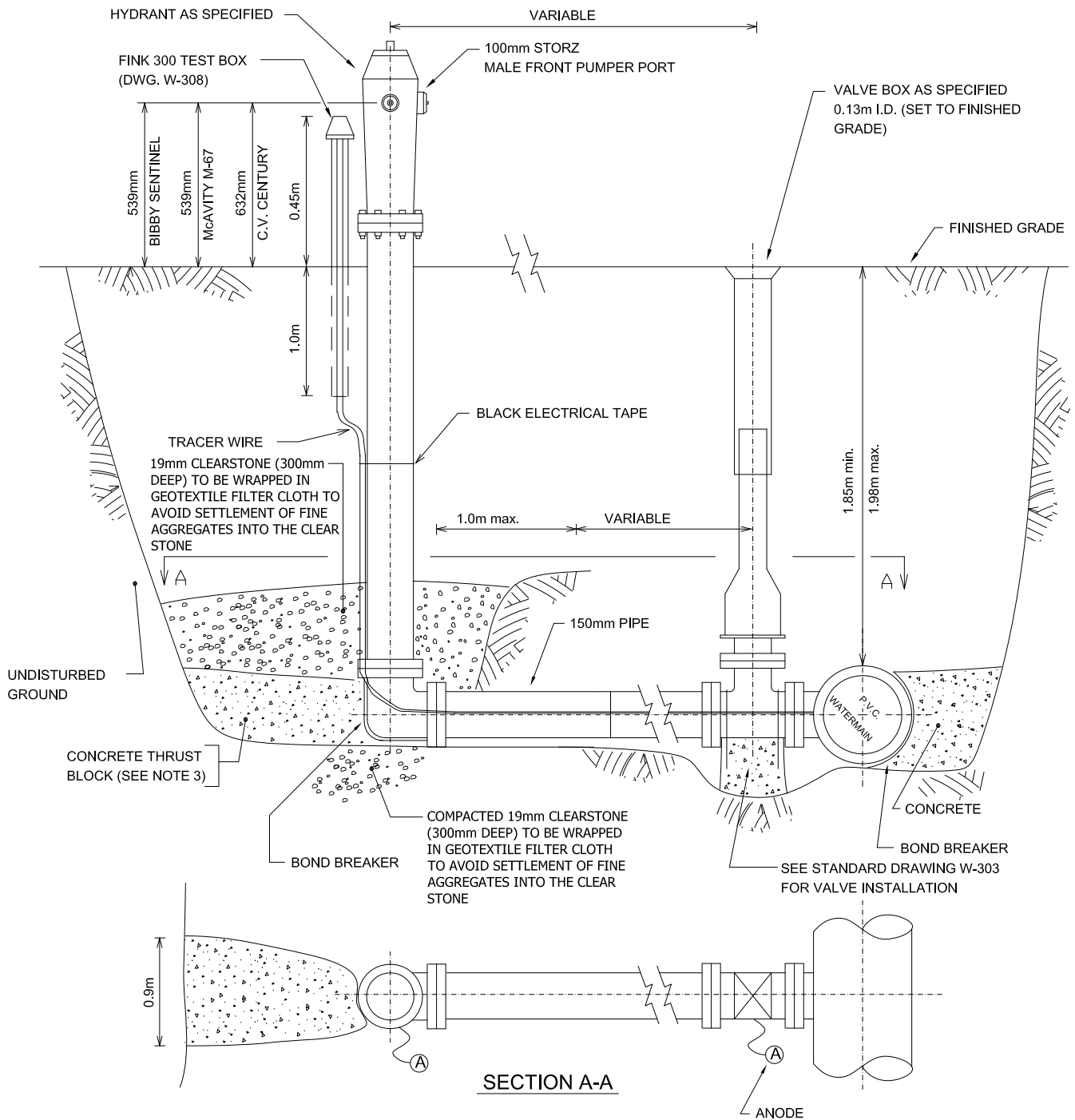

**NOTES:**

1. MIN. STRENGTH OF CONCRETE 20MPa UNLESS SPECIFIED OTHERWISE.
2. ALL CONCRETE BLOCK TO BE POURED AGAINST UNDISTURBED GROUND.
3. AS AN ALTERNATIVE TO CONCRETE THRUST BLOCK, HORIZONTAL TIE RODS FROM BOOT TO GATE VALVE WILL BE CONSIDERED. CONTRACTOR TO CONFIRM WITH CORPORATION'S INSPECTOR.
4. APPROVED HYDRANTS ARE DARLING CENTURY, McAVITY M.67, BIBBY SENTINEL AND AVK 2780 NOSTALIC. IF HYDRANT RISERS ARE REQUIRED, THEY SHALL BE INSTALLED AT THE BOOT OF THE DARLING CENTURY, AT THE TOP OF THE McAVITY M.67.
5. PROVIDE 300mm OF CLEAR STONE BELOW THE BOOT.



**HYDRANT INSTALLATION C/W  
ANCHOR TEE, VALVE AND TEST  
POINT FOR P.V.C. WATERMAIN**

ENGINEERING SERVICES  
DEPARTMENT

DATE: JULY 1985

REV: NOV. 2021

N.T.S.

**W-504A**

DRAWN BY:  
J. RATANAVANH

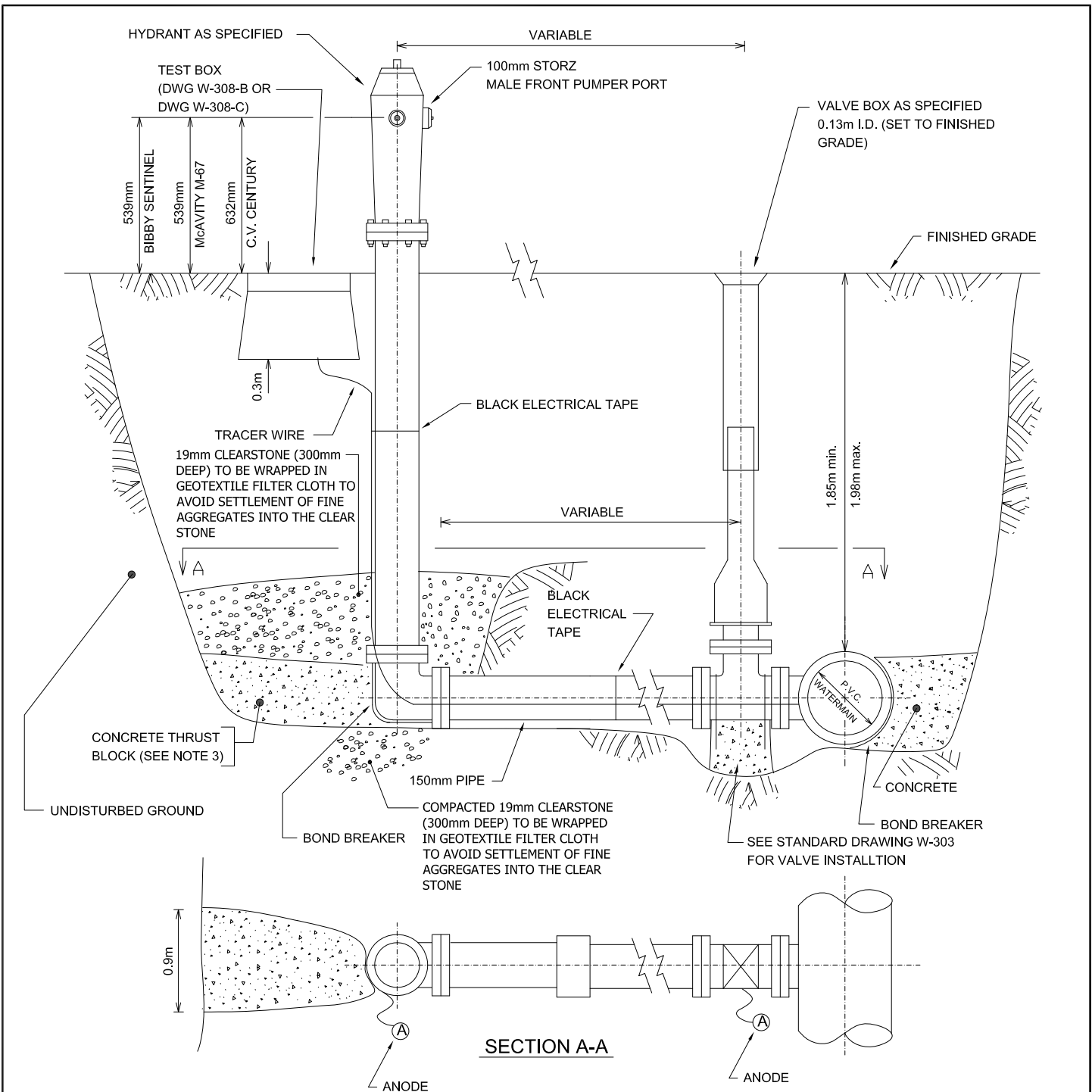

**NOTES:**

1. MIN. STRENGTH OF CONCRETE 20MPa UNLESS SPECIFIED OTHERWISE.
2. ALL CONCRETE BLOCK TO BE POURED AGAINST UNDISTURBED GROUND.
3. AS AN ALTERNATIVE TO CONCRETE THRUST BLOCK, HORIZONTAL TIE RODS FROM BOOT TO GATE VALVE WILL BE CONSIDERED. CONTRACTOR TO CONFIRM WITH CORPORATION'S INSPECTOR.
4. APPROVED HYDRANTS ARE CANADA VALVE(CENTURY), McAVITY M-67, BIBBY SENTINEL AND AVK 2780 NOSTALGIC. IF HYDRANT RISERS ARE REQUIRED, THEY SHALL BE INSTALLED AT THE BOOT OF THE CANADA VALVE(CENTURY), AT THE TOP OF THE McAVITY M-67 AND BIBBY SENTINEL.
5. PROVIDE 300mm OF CLEAR STONE BELOW BOOT.



**HYDRANT INSTALLATION C/W  
ANCHOR TEE, VALVE AND TEST  
POINT FOR P.V.C. WATERMAIN**

ENGINEERING SERVICES  
DEPARTMENT

DATE: DEC. 1989

REV: NOV. 2021

N.T.S.

**W-504B**

DRAWN BY:  
J. RATANAVANH

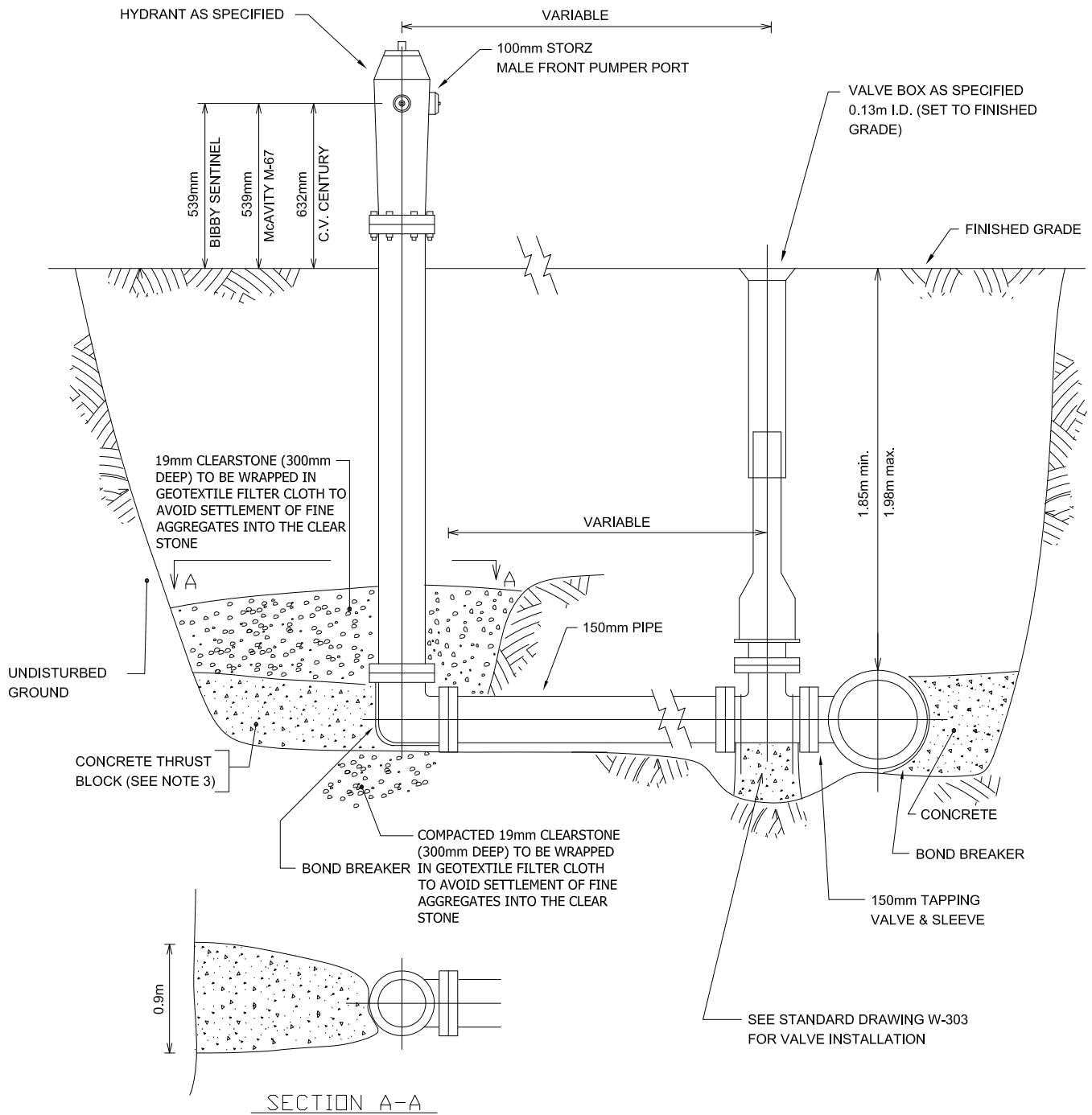

**NOTES:**

1. MIN. STRENGTH OF CONCRETE 20MPa UNLESS SPECIFIED OTHERWISE.
2. ALL CONCRETE BLOCK TO BE POURED AGAINST UNDISTURBED GROUND.
3. AS AN ALTERNATIVE TO CONCRETE THRUST BLOCK, HORIZONTAL TIE RODS FROM BOOT TO GATE VALVE WILL BE CONSIDERED. CONTRACTOR TO CONFIRM WITH CORPORATION'S INSPECTOR.
4. APPROVED HYDRANTS ARE CANADA VALVE (CENTURY), McAVITY M-67, BIBBY SENTINEL AND AVK 2780 NOSTALGIC. IF HYDRANT RISERS ARE REQUIRED, THEY SHALL BE INSTALLED AT THE BOOT OF THE CANADA VALVE (CENTURY), AT THE TOP OF THE McAVITY M-67 AND BIBBY SENTINEL.
5. PROVIDE 300mm OF CLEAR STONE BELOW THE BOOT.



## HYDRANT DETAIL WITH TAPPING VALVE AND SLEEVE

ENGINEERING SERVICES  
DEPARTMENT

DATE: JULY 1985

REV: NOV. 2021

N.T.S.

**W-505**

DRAWN BY:  
J. RATANAVANH

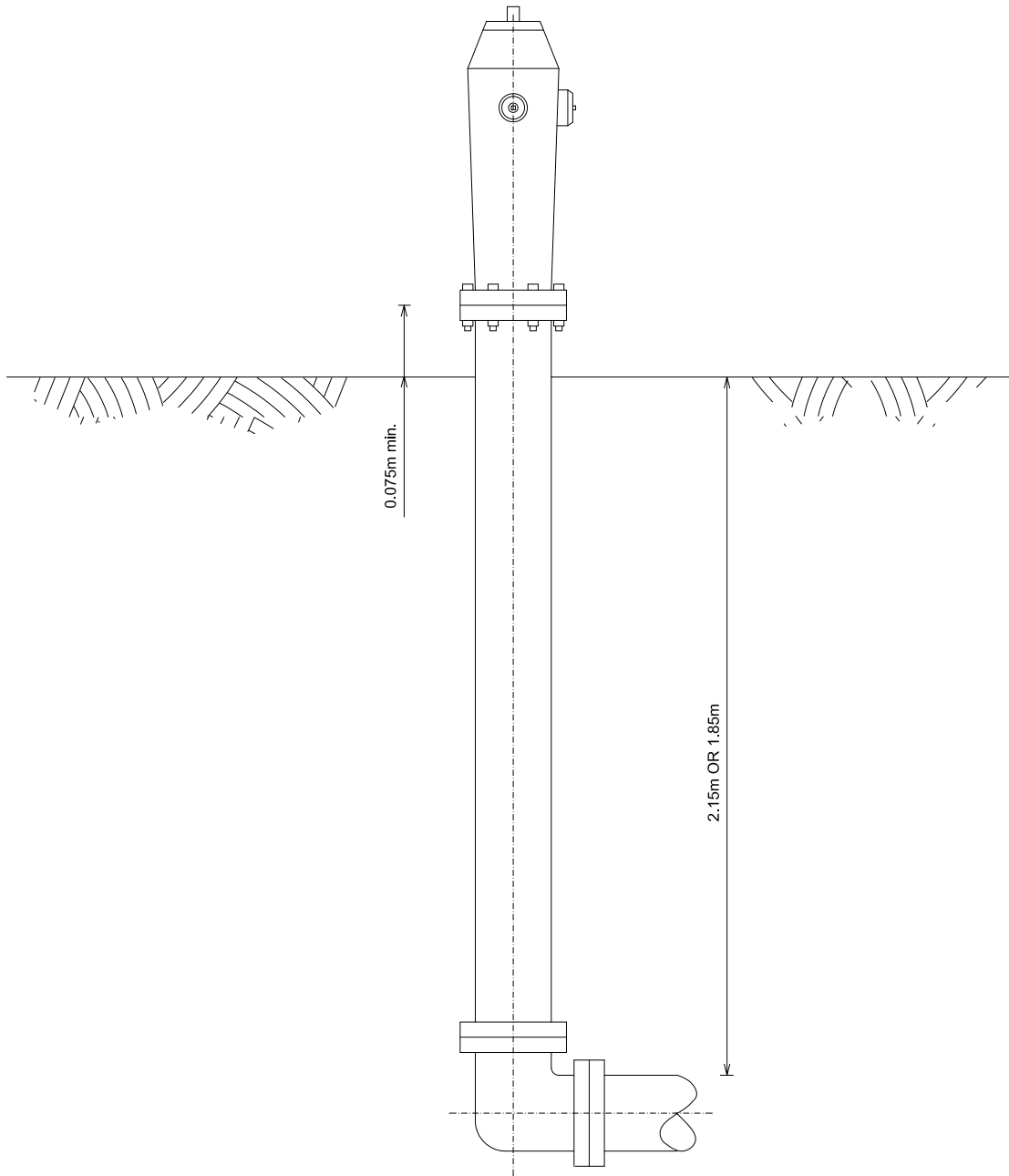

### TYPICAL INSTALLATION DEPTH

ENGINEERING SERVICES  
DEPARTMENT

DATE: JUNE 1987  
REV: NOV. 2021

N.T.S.

**W-506**

DRAWN BY:  
J. RATANAVANH

IMPORTANT: DISCONNECT ONLY THE LOWER BOLTS  
OF THE SPIDER. DO NOT REMOVE UPPER BOLTS.

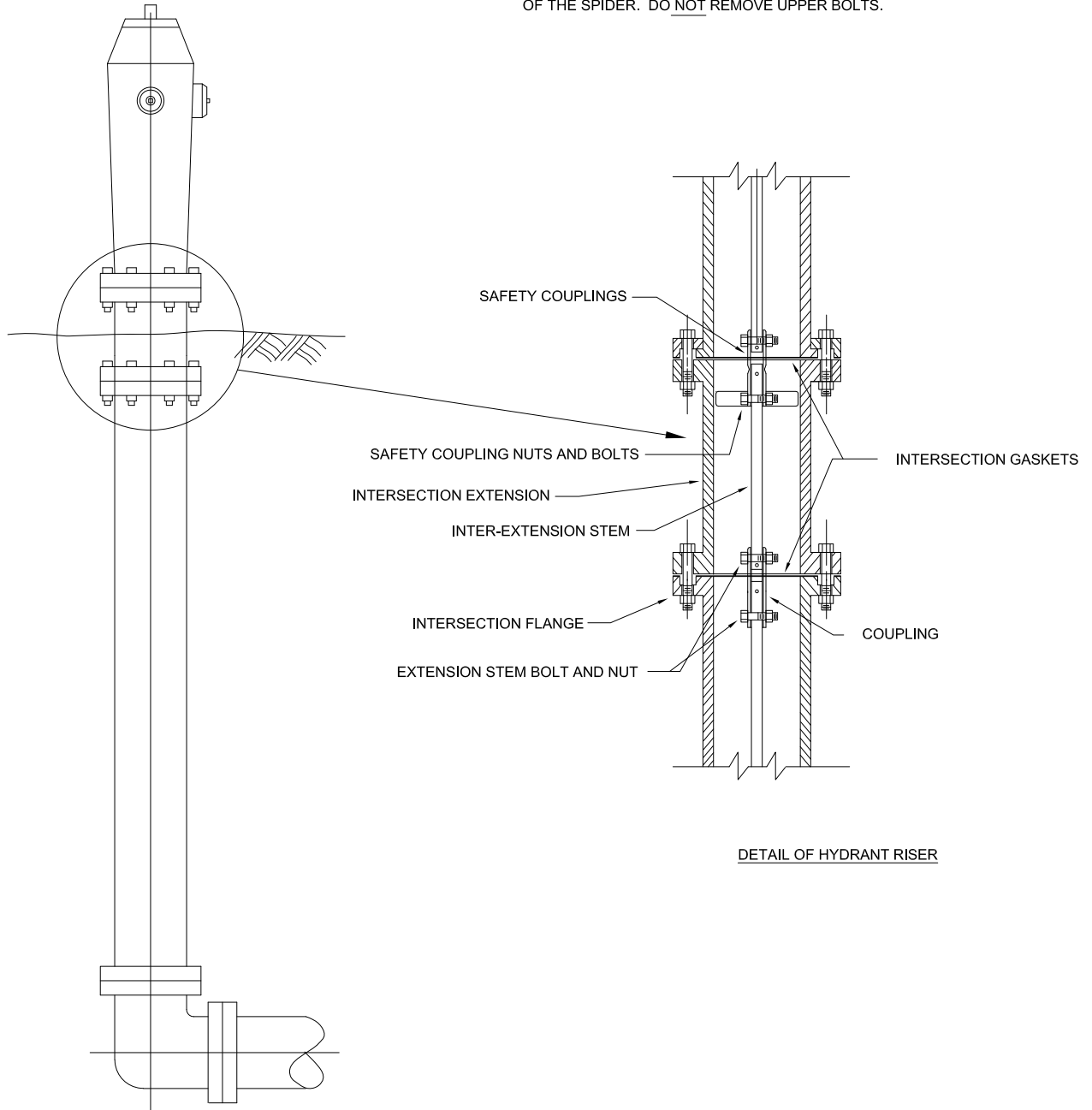

McAVITY HYDRANT C/W HYDRANT RISER

DETAIL OF HYDRANT RISER

INSTRUCTIONS TO INCREASE LENGTH OF BURY

1. UNSCREW BODY CAP COVER SCREWS, AND REMOVE.
2. UNSCREW BODY CAP ANTI-CLOCKWISE.
3. REMOVE BODY CAP ASSEMBLY.
4. REMOVE SAFETY FLANGES.
5. LIFT OFF THE HYDRANT BODY.
6. REMOVE SAFETY STEM COUPLING FROM OPERATING STEM LOWER.
7. JOIN THE INTERMEDIATE EXTENSION STEM TO THE LOWER OPERATING STEM WITH BOLTS AND NUTS.
8. JOIN THE UPPER OPERATING STEM TO THE INTER EXTENSION STEM AND REASSEMBLE.



**TYPICAL RISER INSTALLATION  
McAVITY HYDRANT**

ENGINEERING SERVICES  
DEPARTMENT

DATE: JUNE 1987

REV: NOV. 2021

N.T.S.

**W-506A**

DRAWN BY:  
J. RATANAVANH



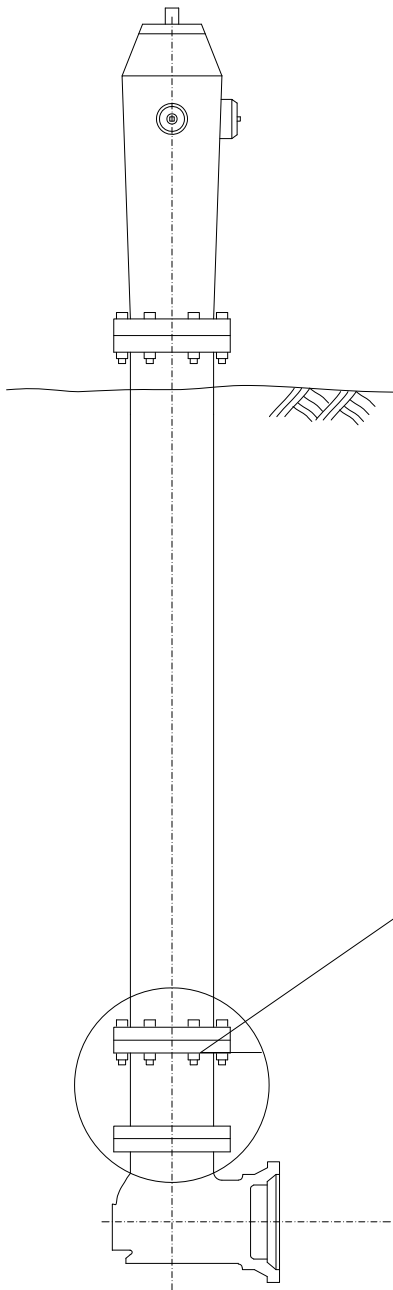

CANADA VALVE HYDRANT

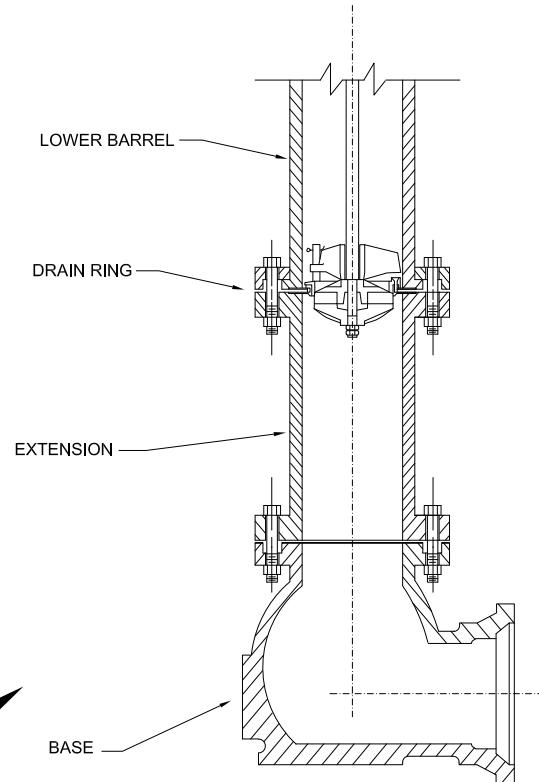

**PARTS REQUIRED FOR THE INSTALLATION OF EXTENSION:**

- 1. ONE 8 HOLE BARREL EXTENSION X LENGTH COMPLETE WITH GASKETS AND BOLTS.



**TYPICAL EXTENSION  
INSTALLATION FOR CENTURY,  
B-50-B-18 AND  
B-50-B-24 HYDRANT**

ENGINEERING SERVICES  
DEPARTMENT

DATE: AUG. 1987  
REV: NOV. 2021

N.T.S.

**W-506B**

DRAWN BY:  
J. RATANAVANH

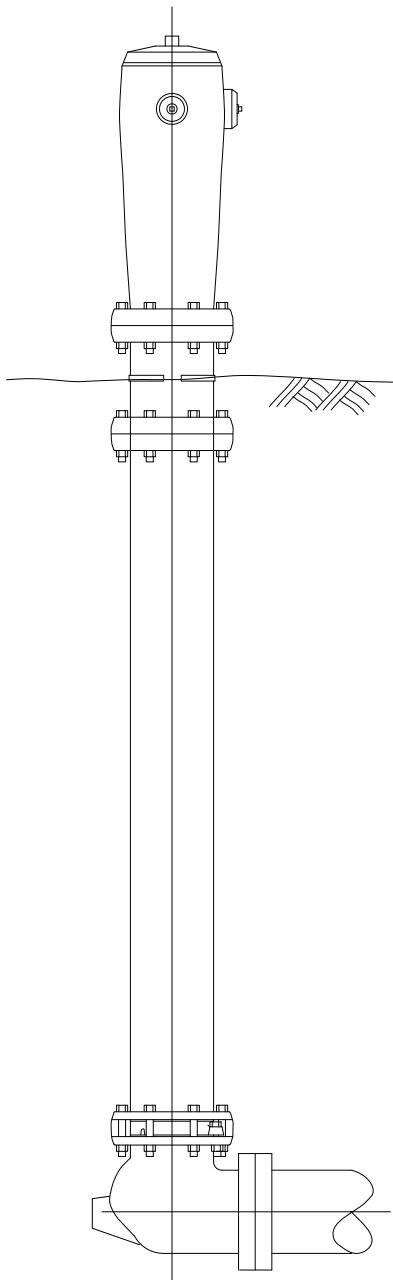

MUELLER HYDRANT

SAFETY STEM COUPLING TO BE AT BREAK AWAY FLANGE

EXTENSION

LOWER BARREL

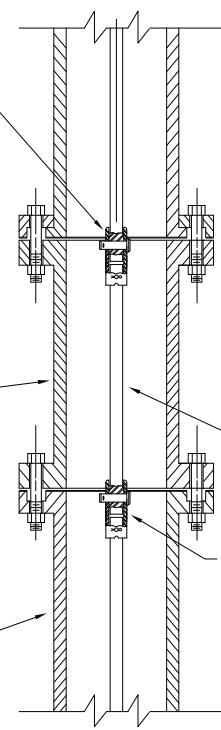

EXTENSION STEM

EXTENSION COUPLING

NOTE: CONSULT MUELLER HYDRANT OPERATING INSTRUCTIONS FOR METHOD OF INSERTING EXTENSION SECTION



TYPICAL EXTENSION  
INSTALLATION FOR MODERN  
CENTURION HYDRANT

ENGINEERING SERVICES  
DEPARTMENT

DATE: AUG. 1987  
REV: NOV. 2021

N.T.S.

W-506C

DRAWN BY:  
J. RATANAVANH

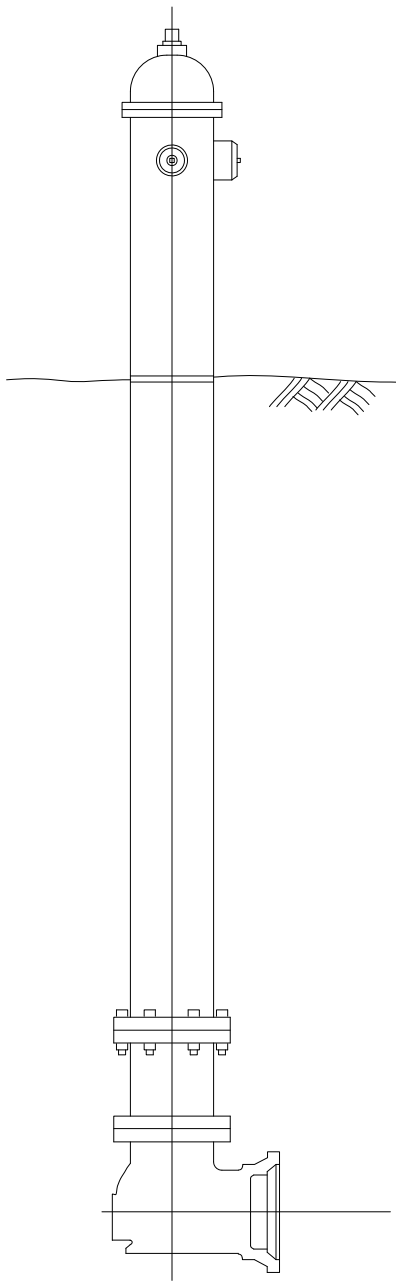

DARLING S-300 HYDRANT

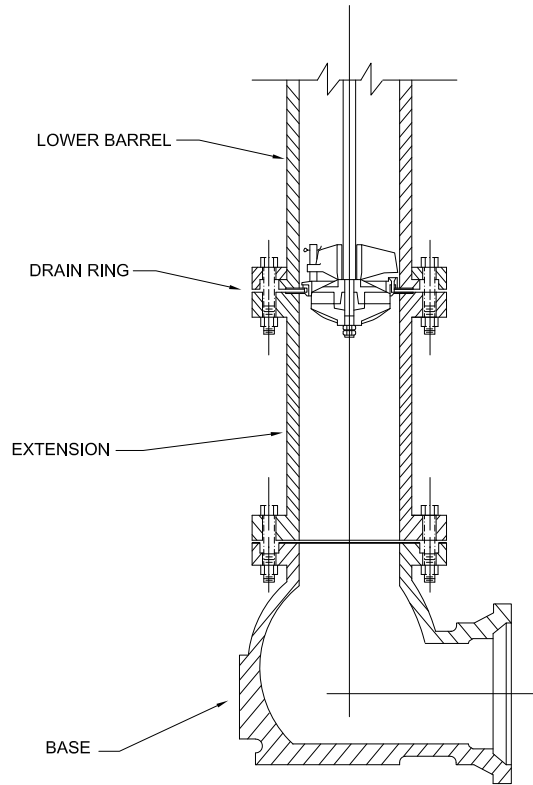

PARTS REQUIRED FOR THE INSTALLATION OF EXTENSION:

1. ONE 6 HOLE BARREL EXTENSION X LENGTH COMPLETE WITH GASKETS AND BOLTS.



**TYPICAL EXTENSION  
INSTALLATION DARLING  
S-300 HYDRANT**

ENGINEERING SERVICES  
DEPARTMENT

DATE: AUG. 1987

REV: NOV. 2021

N.T.S.

**W-506D**

DRAWN BY:  
J. RATANAVANH

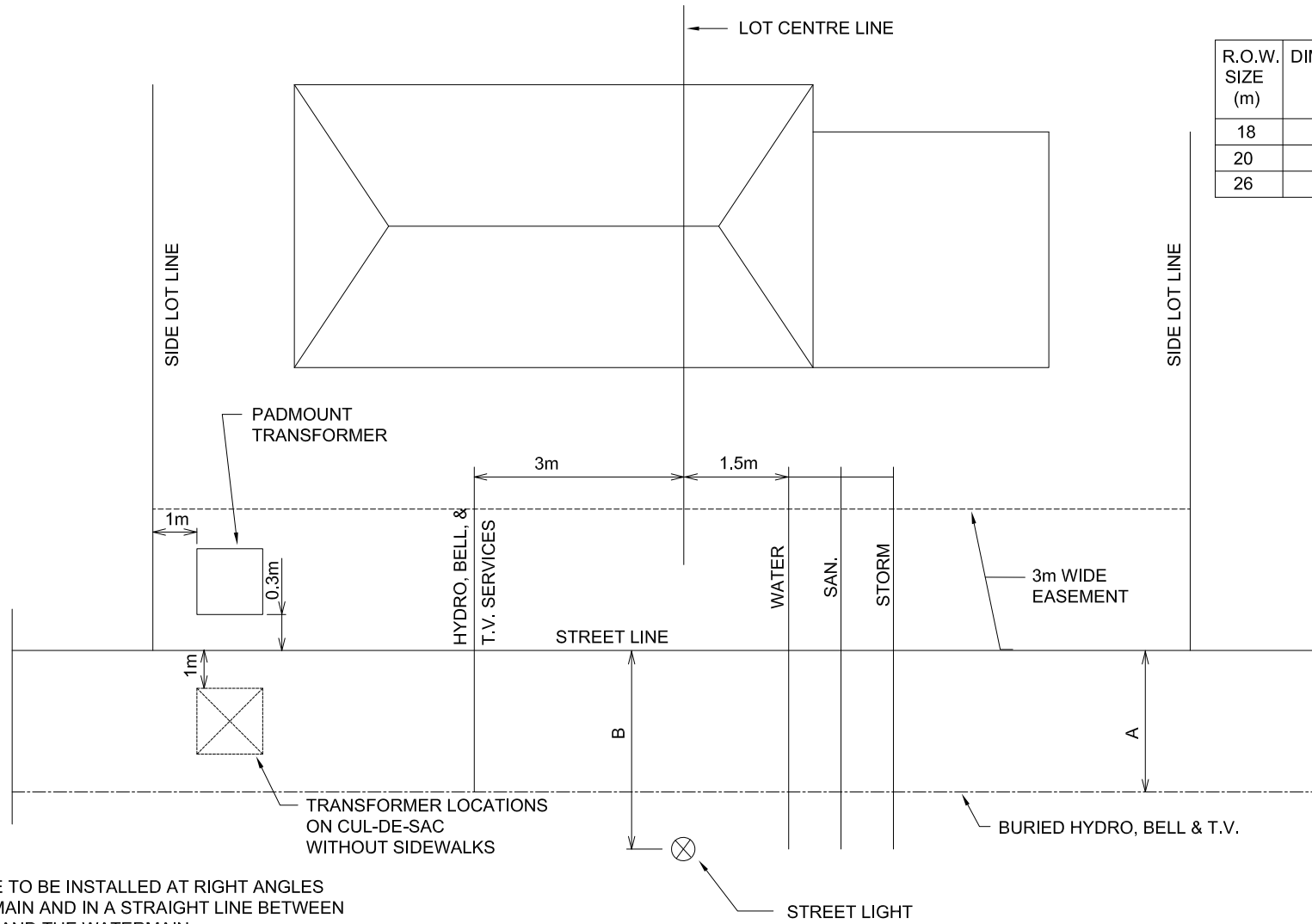

**NOTE:**

WATER SERVICE TO BE INSTALLED AT RIGHT ANGLES TO THE WATERMAIN AND IN A STRAIGHT LINE BETWEEN THE CURBSTOP AND THE WATERMAIN.

WATER SERVICE AT THE END OF A CUL-DE-SAC MAY BE ANGLED.



## TYPICAL WATER SERVICE LOCATION (SINGLE FAMILY LOT) SUBDIVISION

ENGINEERING SERVICES DEPARTMENT	
DATE: FEB. 1982	N.T.S.
REV: NOV. 2021	
W-601	DRAWN BY: J. RATANAVANH

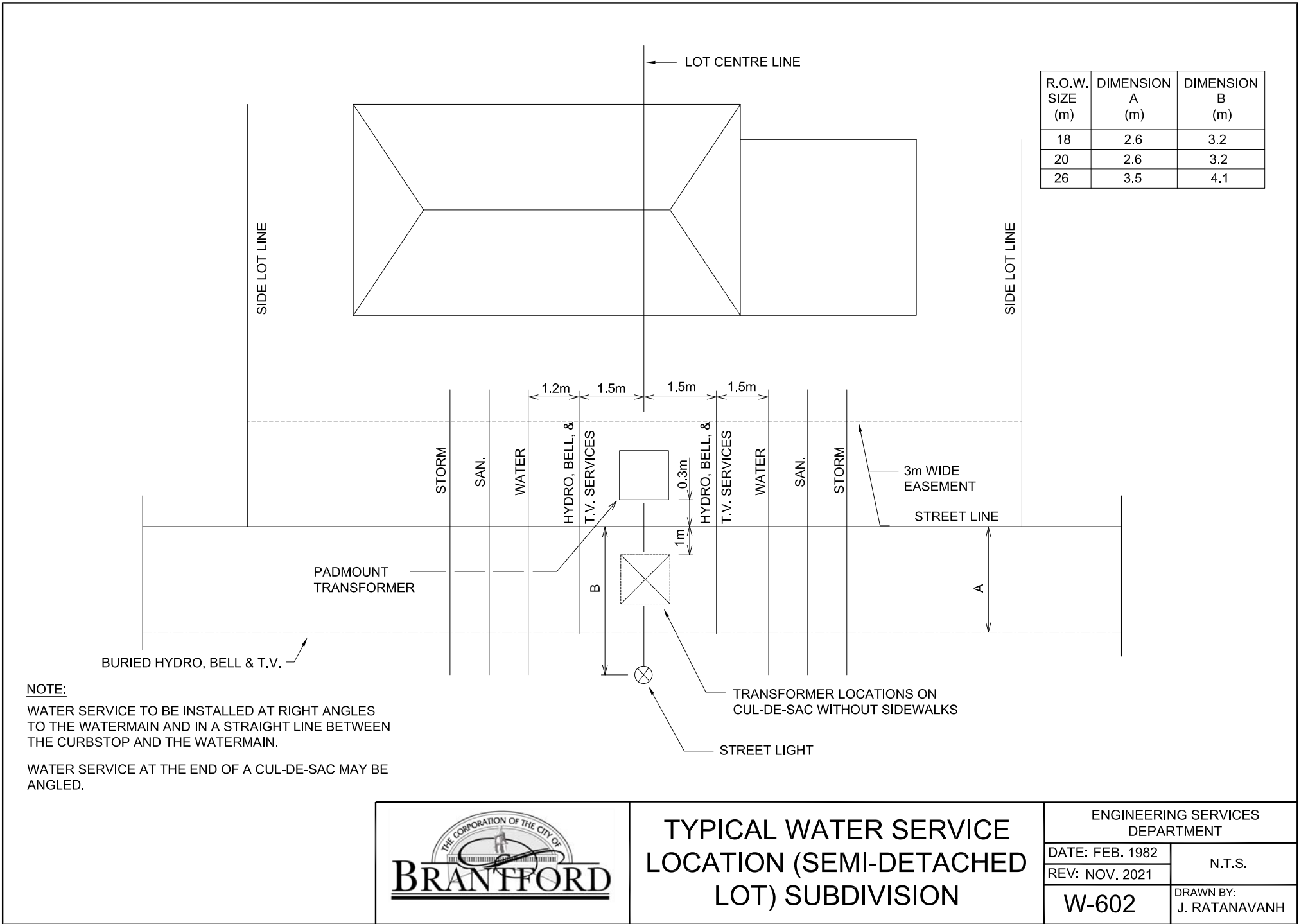

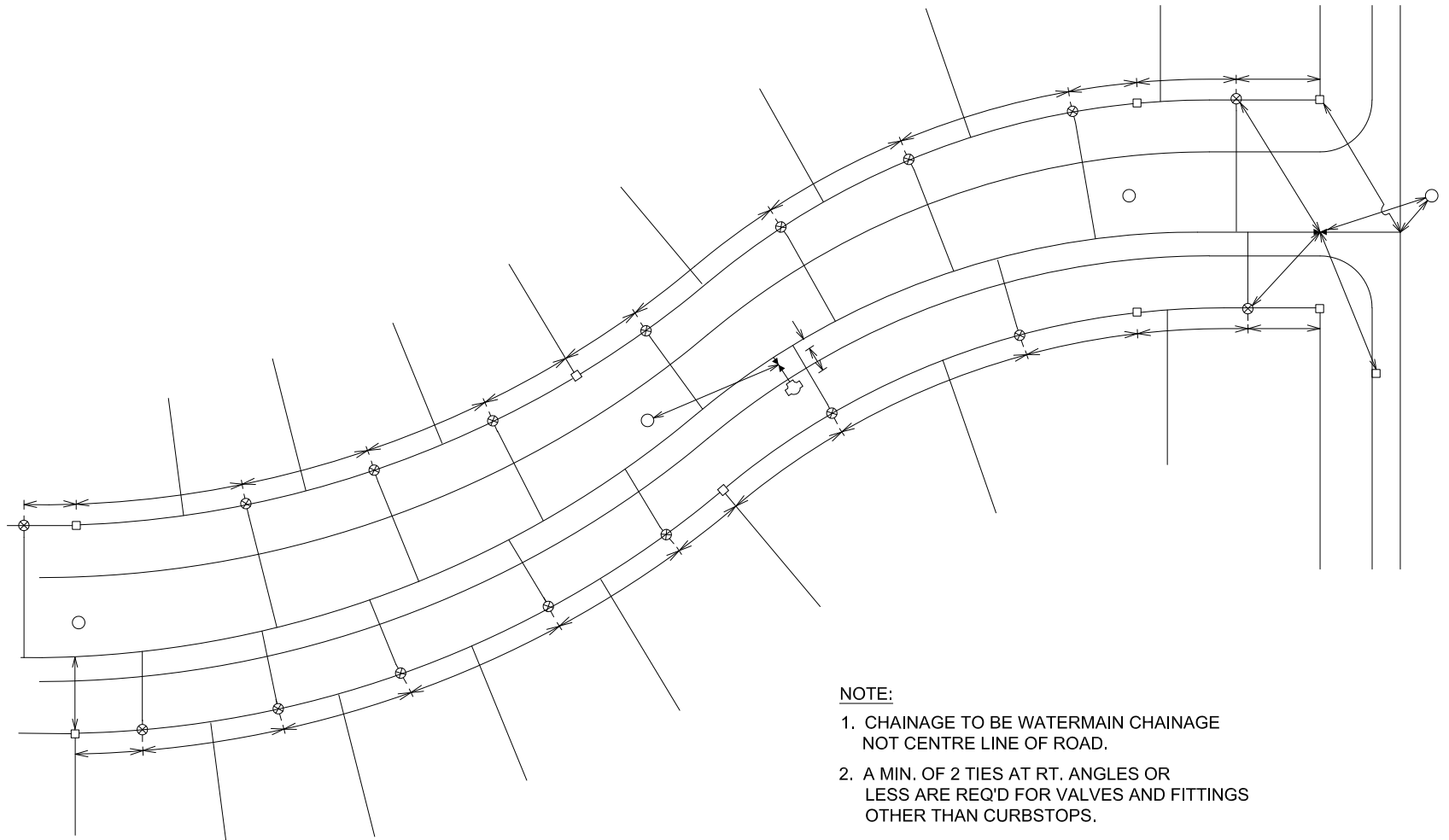

**NOTE:**

1. CHAINAGE TO BE WATERMAIN CHAINAGE  
NOT CENTRE LINE OF ROAD.
2. A MIN. OF 2 TIES AT RT. ANGLES OR  
LESS ARE REQ'D FOR VALVES AND FITTINGS  
OTHER THAN CURBSTOPS.
3. MEASUREMENTS BETWEEN CURBSTOPS ON CURVES  
ARE TO BE CORD MEASUREMENTS.



**STANDARD AS BUILT  
MEASUREMENT FOR  
WATERMAIN CONSTRUCTION**

ENGINEERING SERVICES  
DEPARTMENT

DATE: FEB. 1982

REV: NOV. 2021

N.T.S.

**W-603A**

DRAWN BY:  
J. RATANAVANH

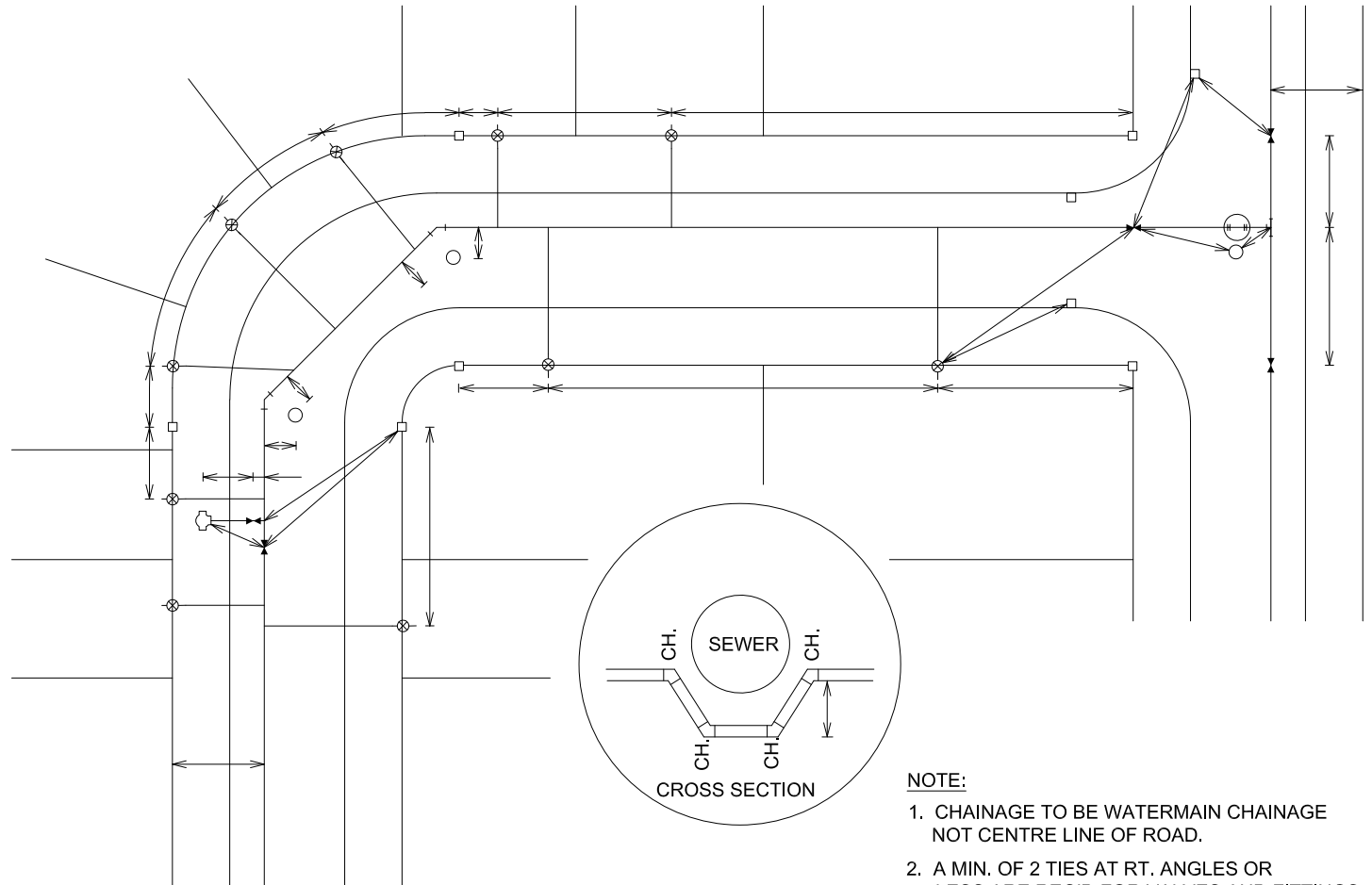

**NOTE:**

1. CHAINAGE TO BE WATERMAIN CHAINAGE NOT CENTRE LINE OF ROAD.
2. A MIN. OF 2 TIES AT RT. ANGLES OR LESS ARE REQ'D FOR VALVES AND FITTINGS OTHER THAN CURBSTOPS.
3. MEASUREMENTS BETWEEN CURBSTOPS ON CURVES ARE TO BE CORD MEASUREMENTS.



**STANDARD AS BUILT  
MEASUREMENT FOR  
WATERMAIN CONSTRUCTION**

ENGINEERING SERVICES  
DEPARTMENT

DATE: FEB. 1982

REV: NOV. 2021

N.T.S.

**W-603B**

DRAWN BY:  
J. RATANAVANH

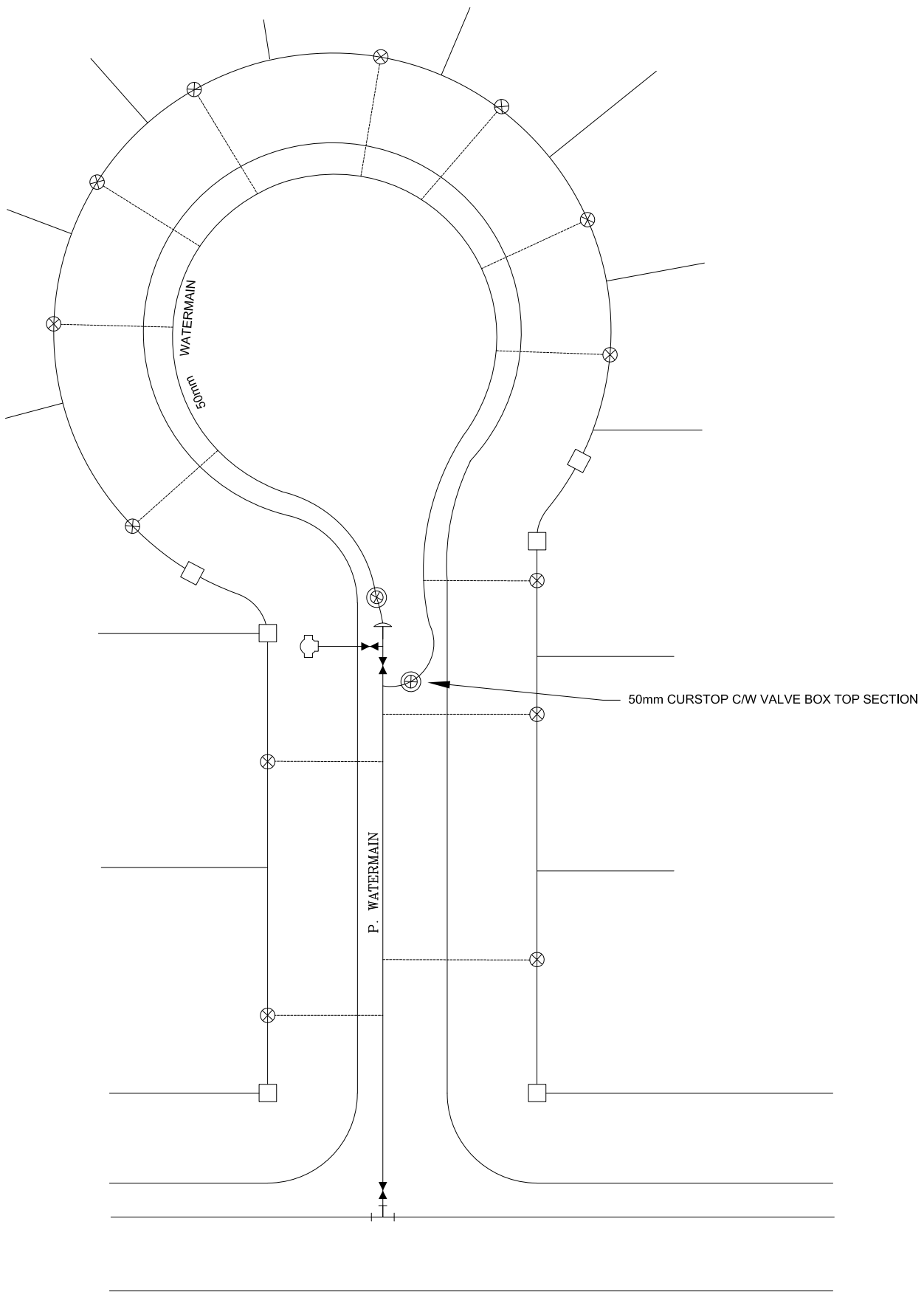

**STANDARD WATERMAIN  
CONSTRUCTION FOR NEW  
CUL-DE-SAC**

ENGINEERING SERVICES  
DEPARTMENT

DATE: JAN. 1994  
REV: NOV. 2021

N.T.S.

**W-604**

DRAWN BY:  
J. RATANAVANH



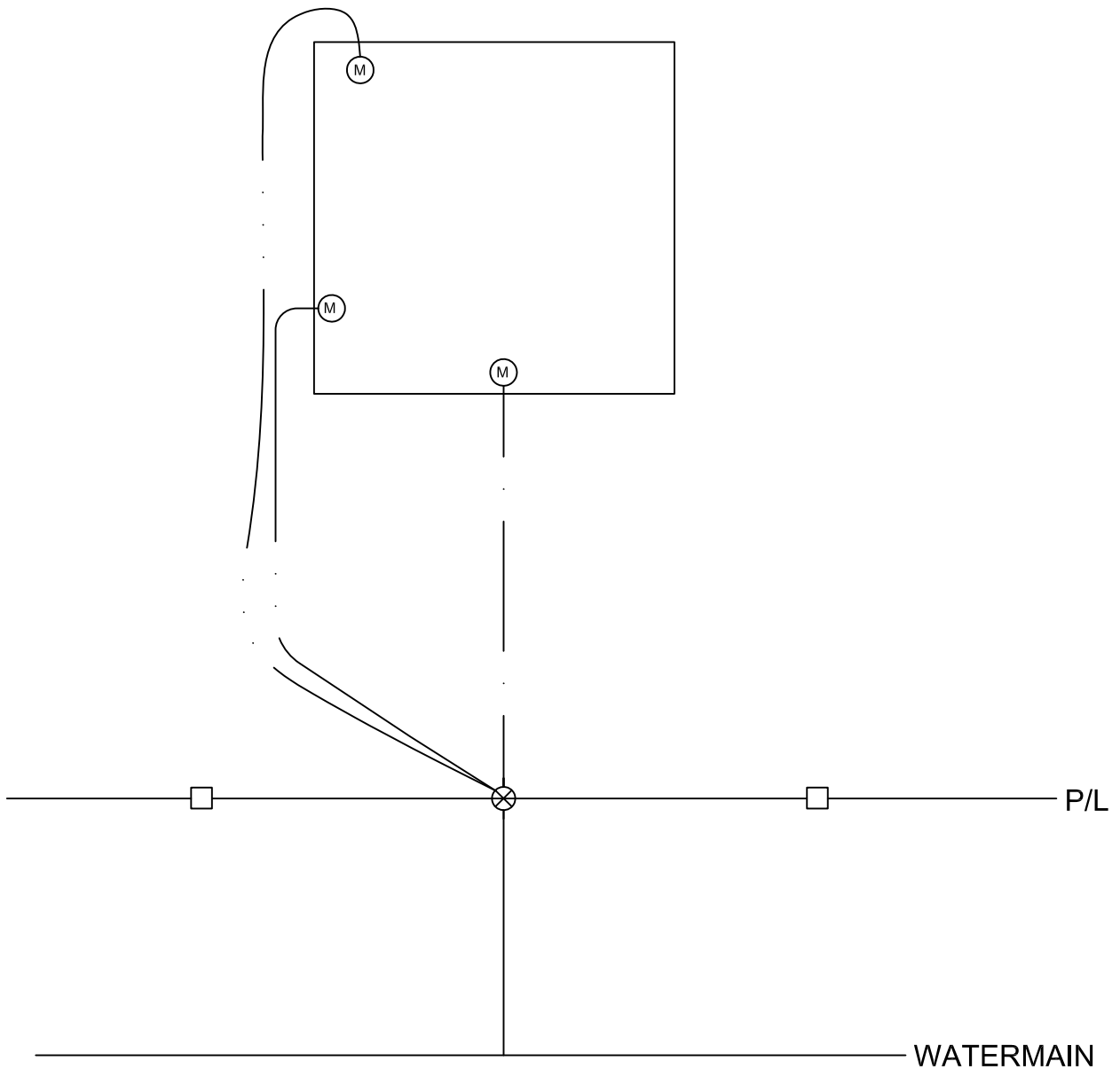

NOTE: The Contractor will be required to install the water service outside the perimeter of the foundation wall to the point where the meter is to be located. The water service will have to be installed under the footings and then immediately brought up through the floor and be meter in accordance with the Corporation's Standard Drawing W-100.

Ⓜ - METER



### TYPICAL WATER METER LOCATION

ENGINEERING SERVICES DEPARTMENT

DATE: APR. 2004

N.T.S.

REV: NOV. 2021

W-605

DRAWN BY:  
J. RATANAVANH

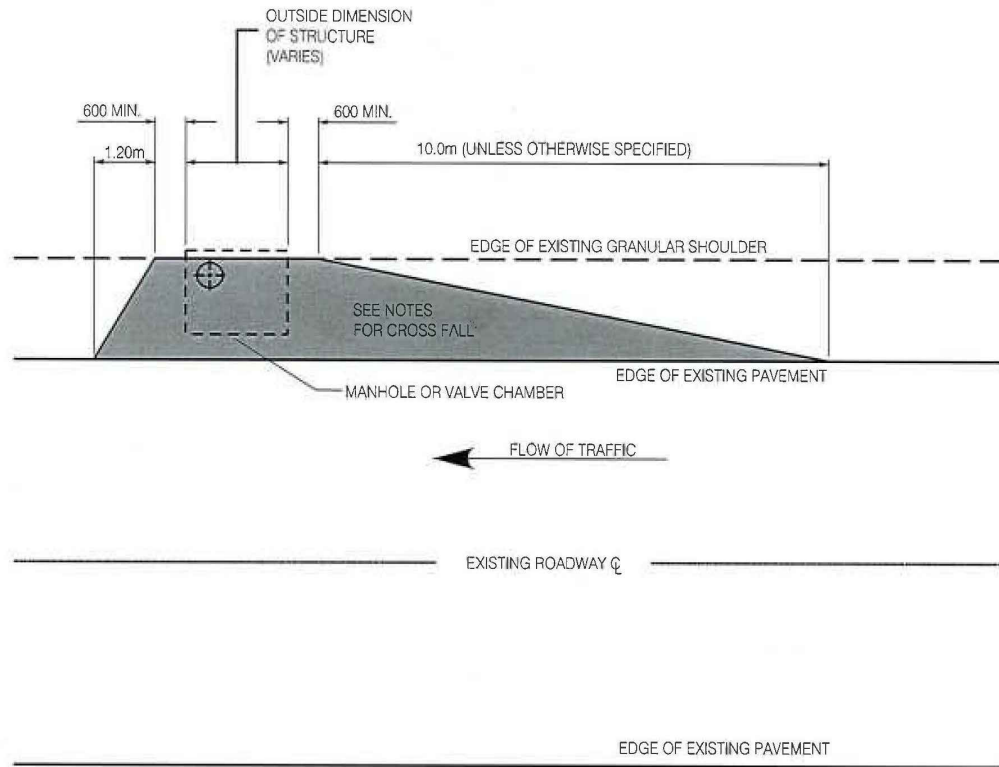

**NOTES:**

1. CROSSFALL OF PROPOSED SHOULDER PAVING TO SUIT EXISTING CONDITIONS
2. CHAMBER COVERS TO BE SET TO MATCH SHOULDER PAVING CROSSFALL
3. AREA TO BE PAVED MINIMUM 75mm SURFACE ASPHALT



Shoulder Paving for Manholes and Chambers in  
Shoulder of Road  
A-101

ENGINEERING SERVICES  
DEPARTMENT

January 2019

N.T.S.

